

EECS 70A: Network Analysis

Homework #3

Due in discussion section,
Wednesday, May 5, 2010.

Problem 1:

-Use nodal analysis to find all node voltages.

-Find i_x .

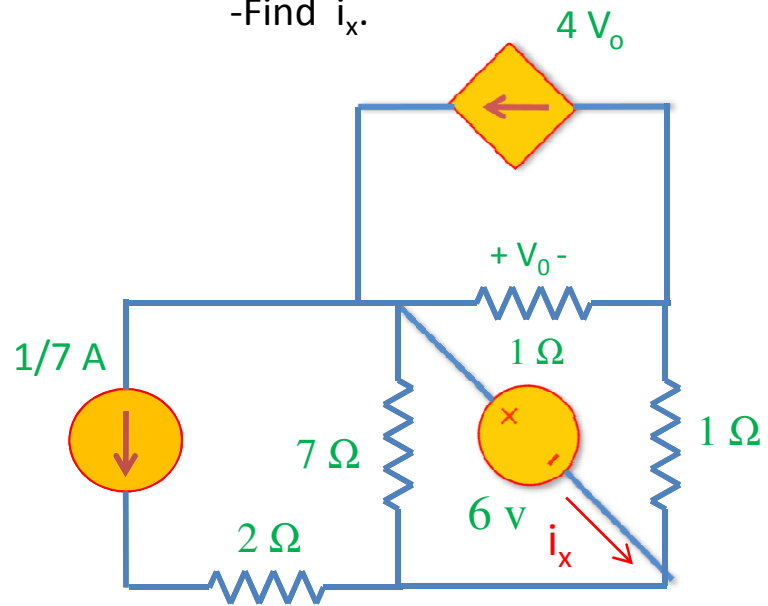

Problem 2: Solve for node voltages.

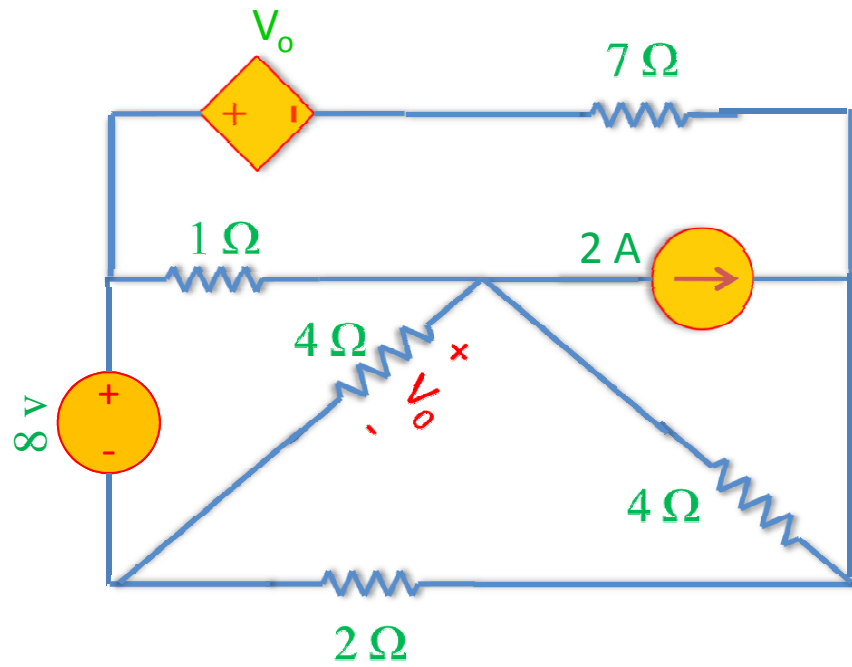

Problem 3:

- Use nodal analysis to find node voltages.
- Find the power supplied by the independent current source.

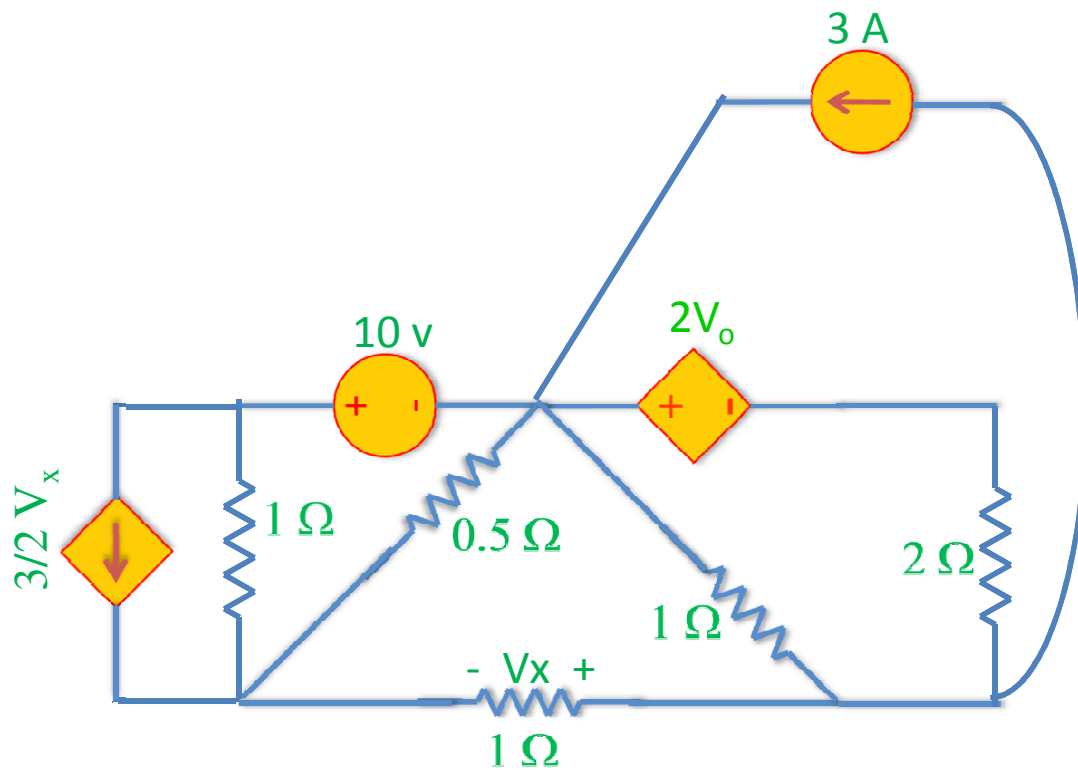

Problem 4: Write the node-voltage equations and put them in matrix form.

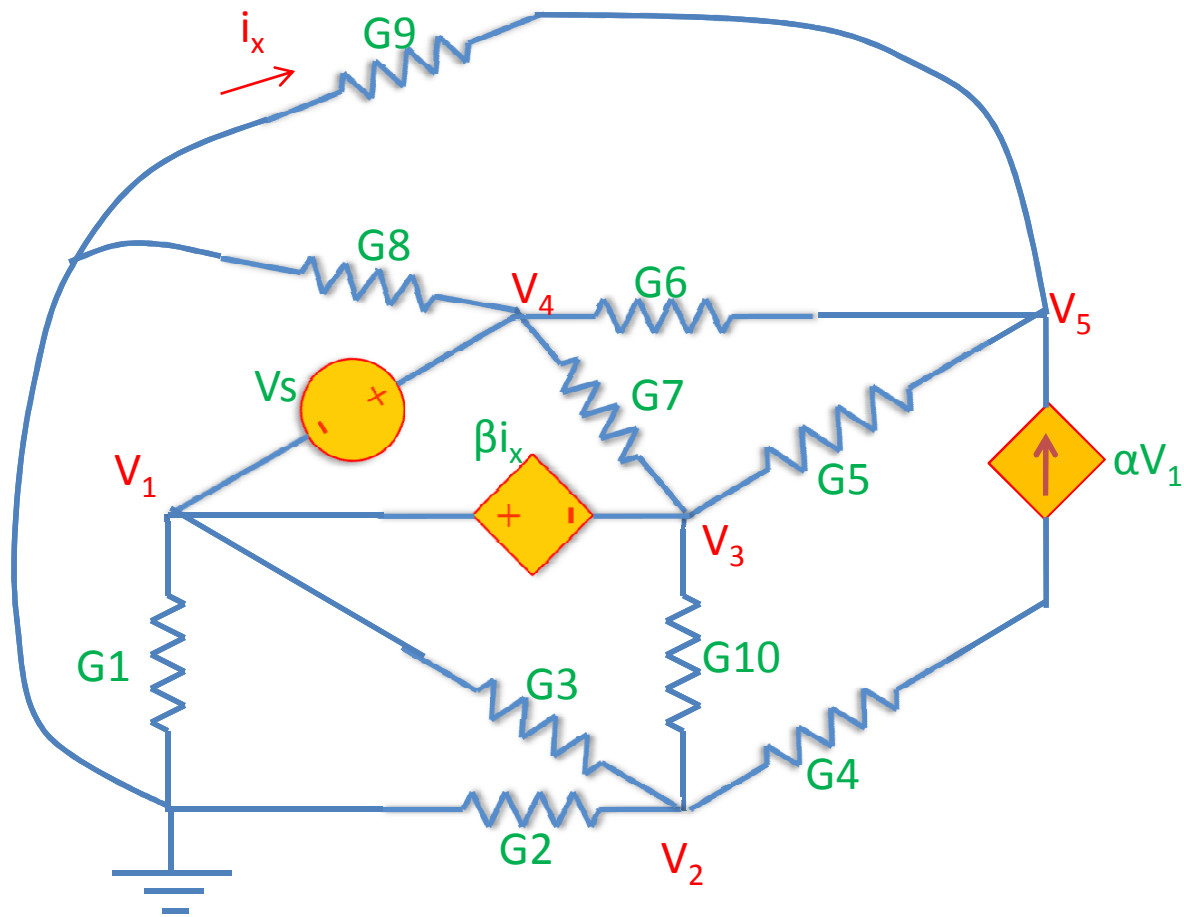

Problem 5: Solve for mesh currents.

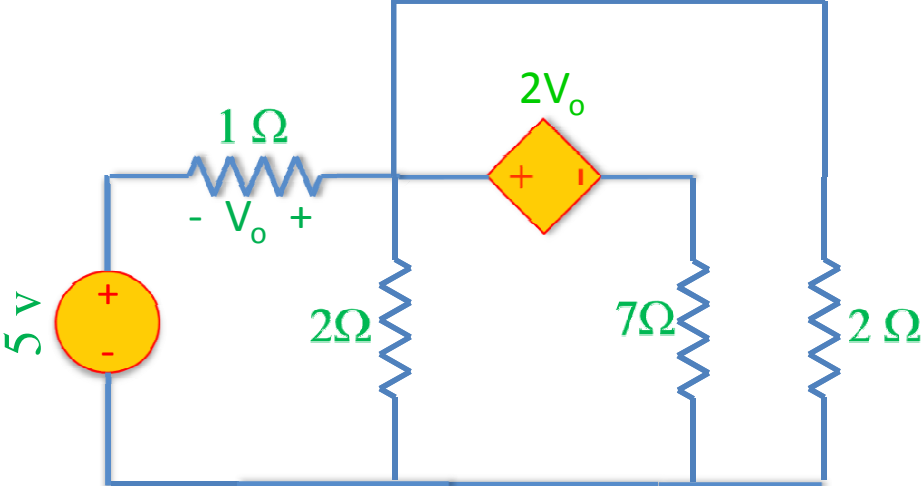

Problem 6:

- Obtain mesh current i_1 through i_3 (in terms of α).
- Find the total power dissipated in R_1 , R_2 and R_3 ($P_1+P_2+P_3$ in terms of α).

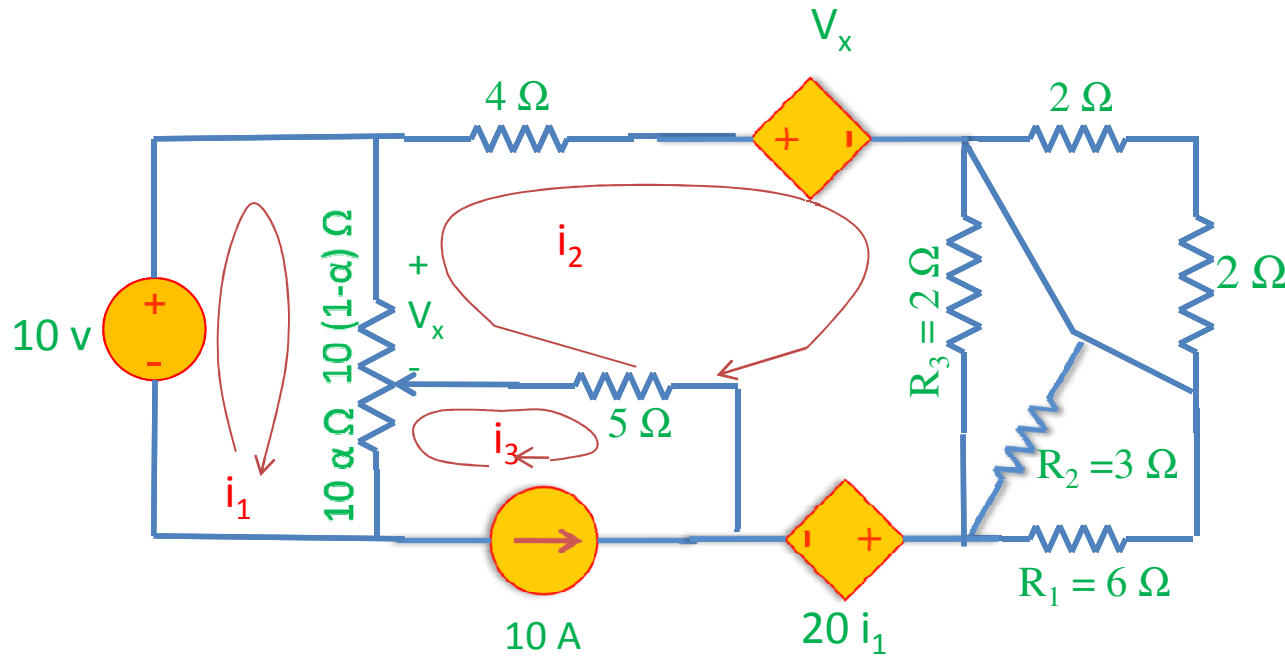

Problem 7: Solve for mesh currents.

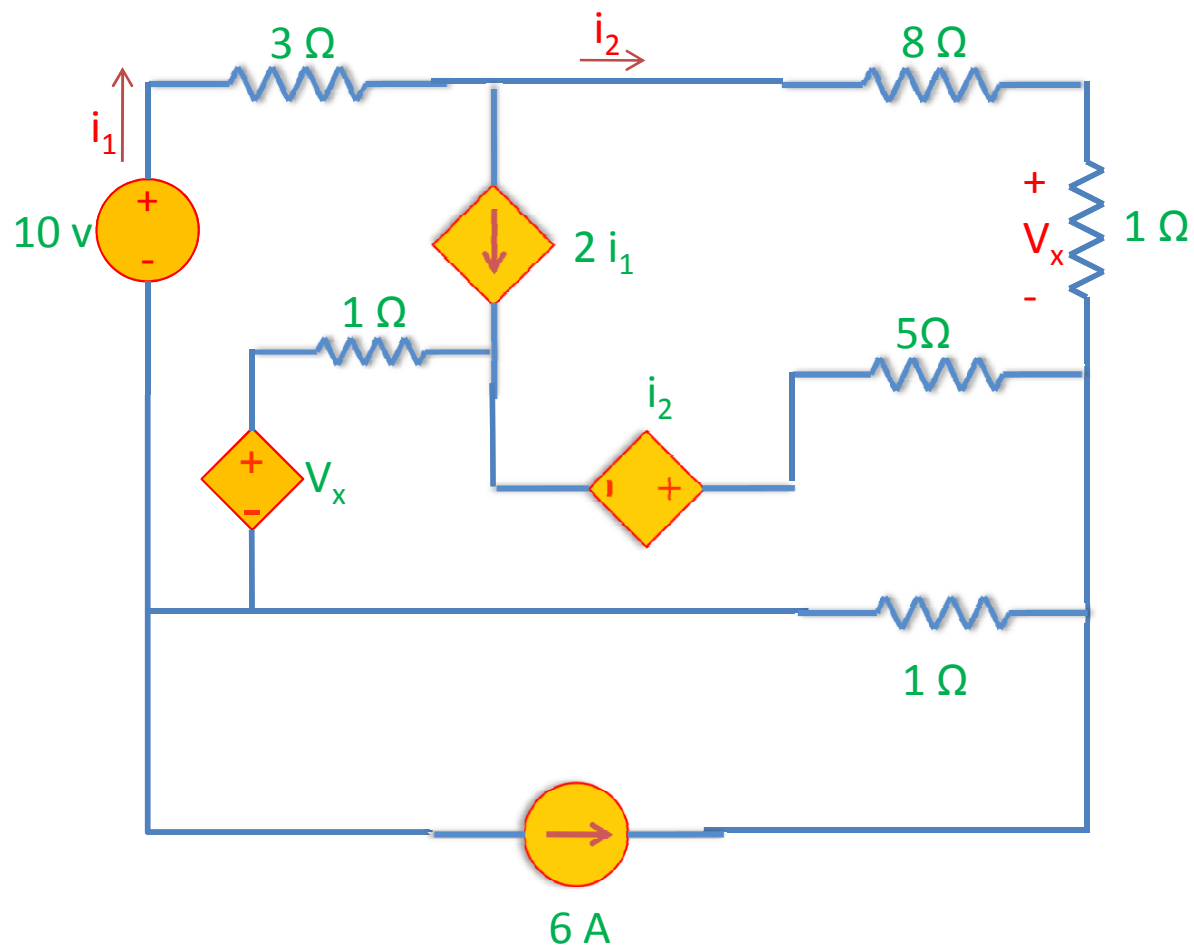

Problem 8: Solve for mesh currents.

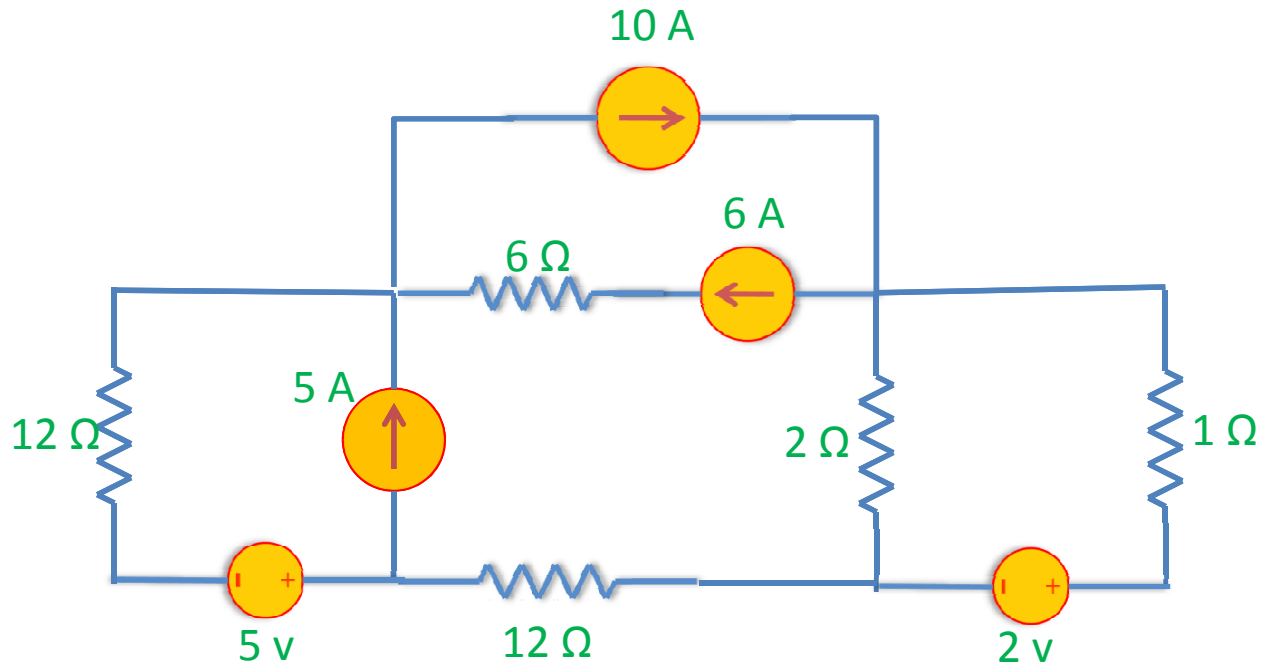

Problem 9: Use your circuit analysis skills to find the ratio of the power absorbed by R_L to the power supplied by V_s .

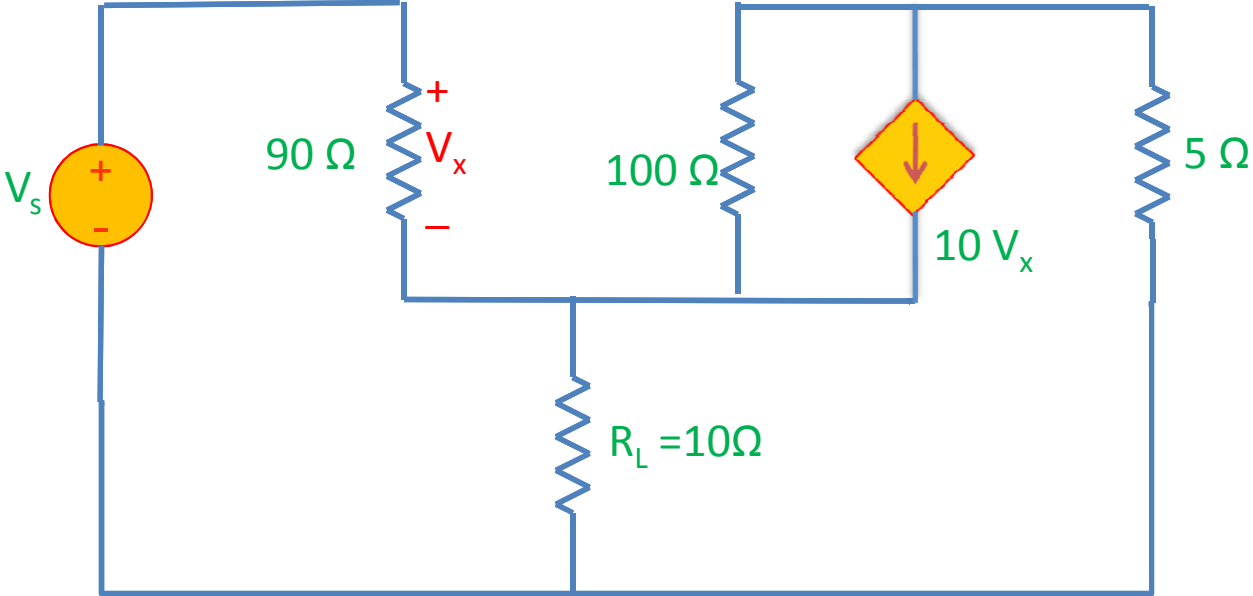

Problem 10: Find i_0 .

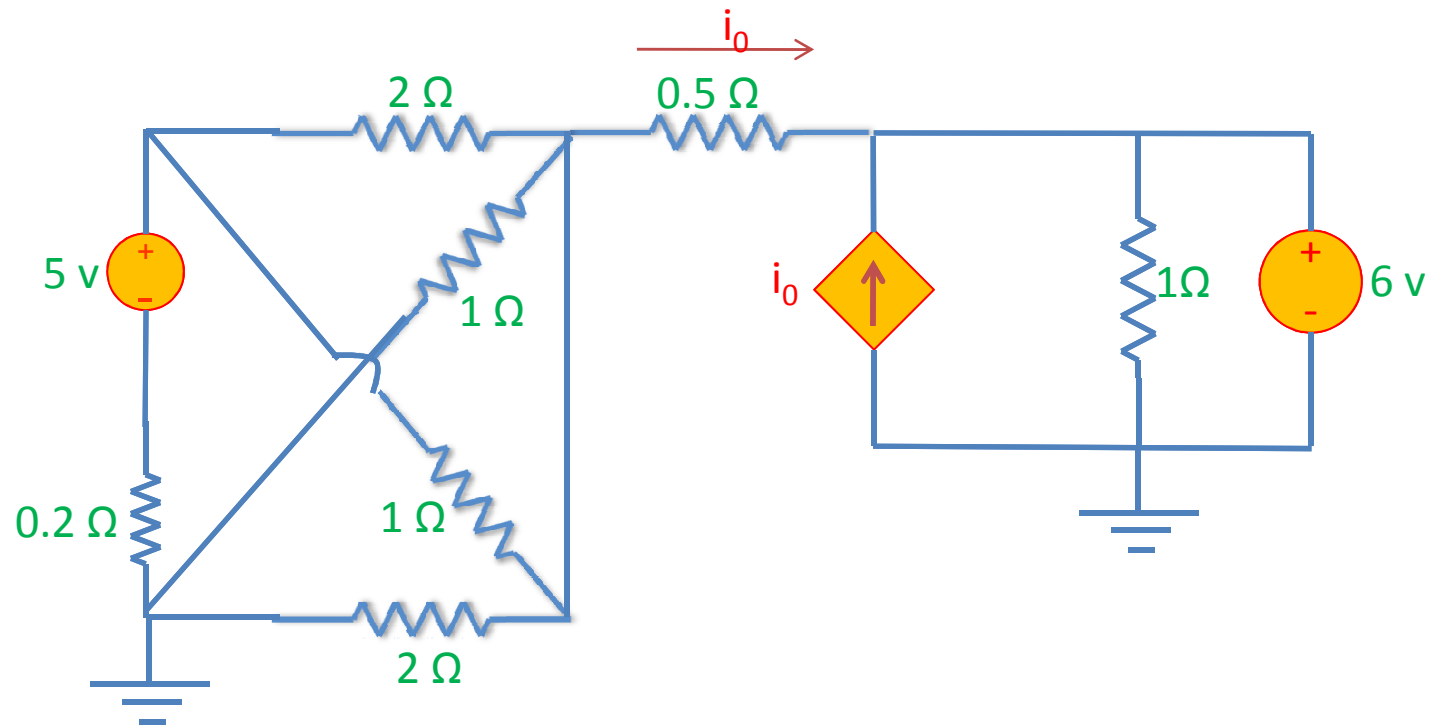

Problem 10: Find node voltages and currents.

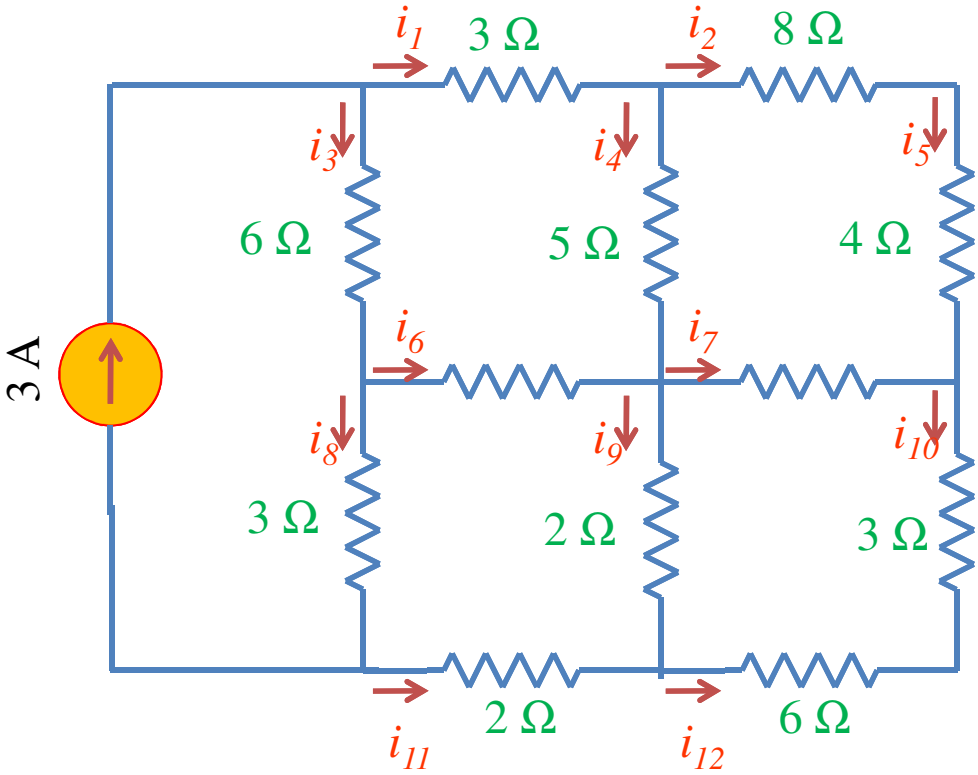

EXTRA CREDIT: Find node voltages and currents

