

Lecture 4: Heterojunction Bipolar Transistors (HBTs)

Bipolar means both electrons,
holes participate in the device.
(In contrast, FET is unipolar.)

Outline for today

- n-p-n homojunction band diagrams
- n-p-n DC I-V curves, etc.
- DC circuit models
- Why are we doing this? YOU, the designer will need to know how different transistor geometries translate into different effective circuit elements.

n-p-n geometry

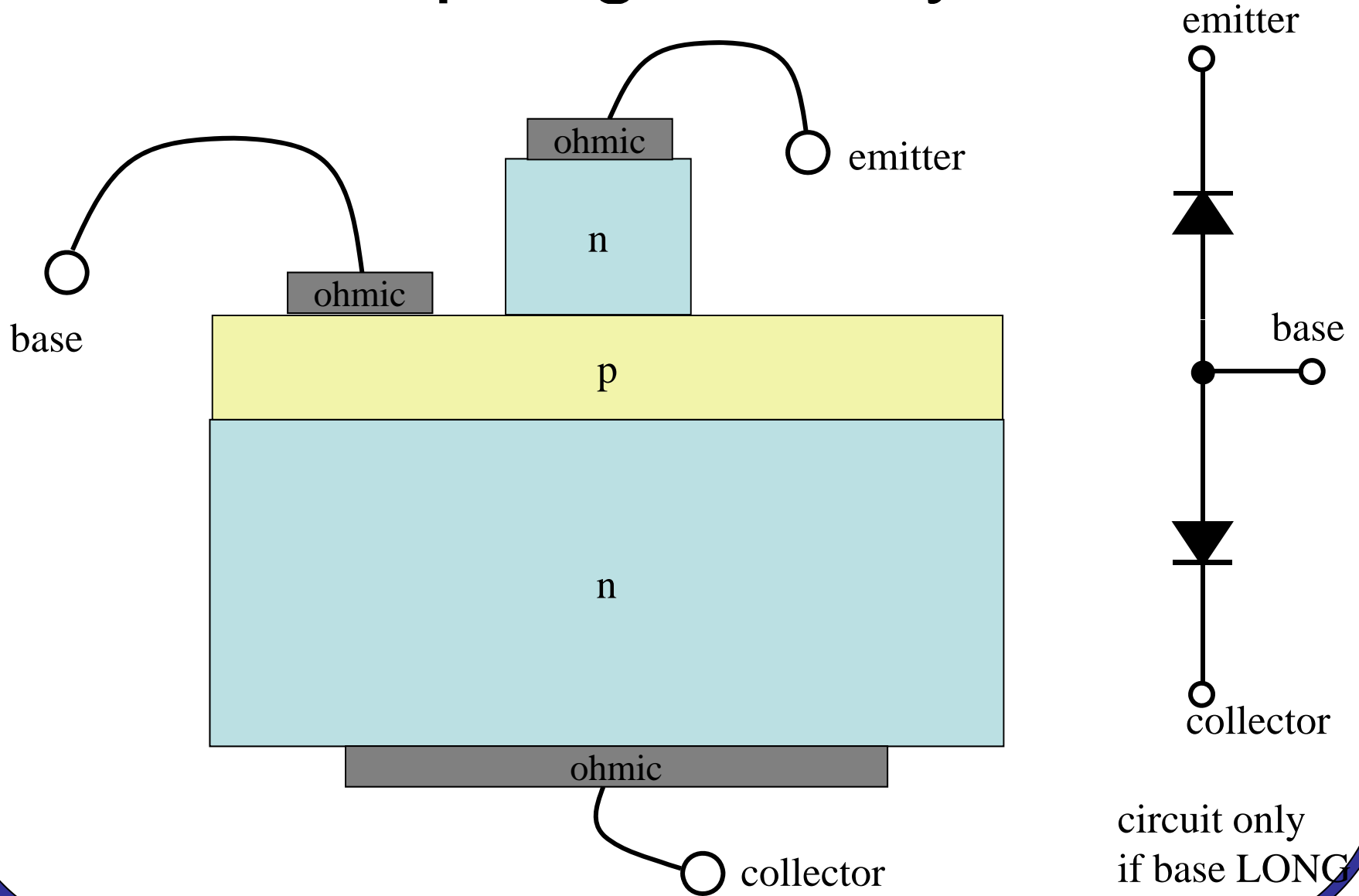

n-p-n junction at zero bias

n

p

n

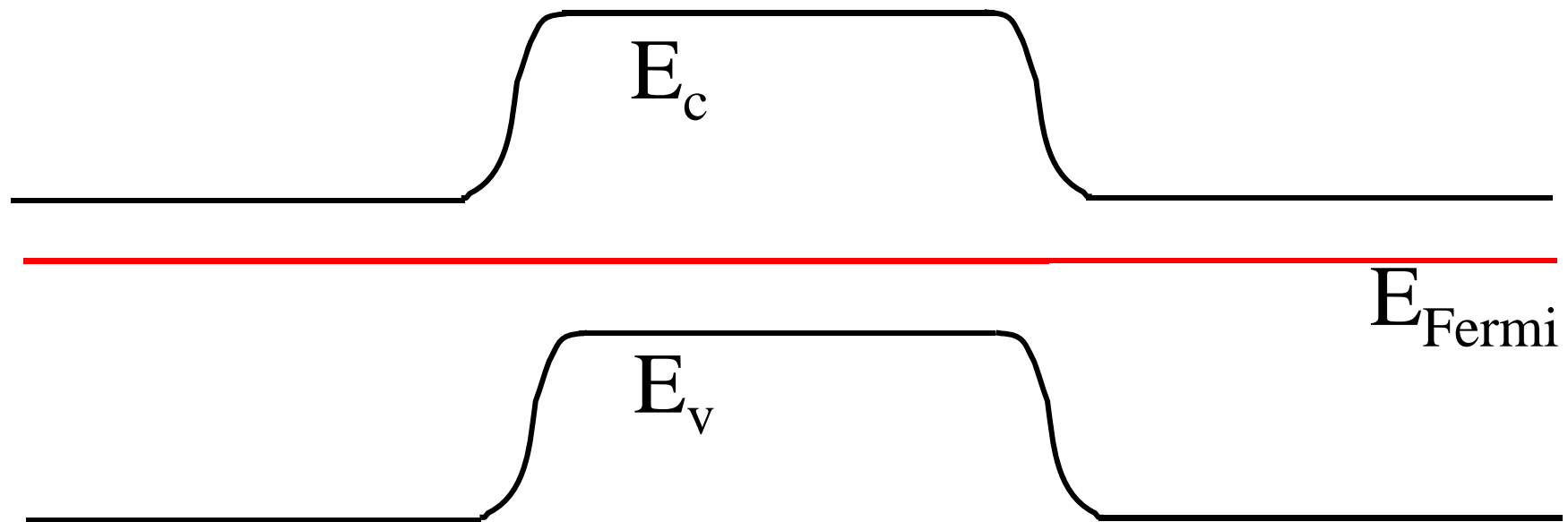

Bias conditions

Mode	E-B	C-B
Normal active	forward	reverse
saturation	forward	forward
cutoff	reverse	reverse

“Normal active” bias

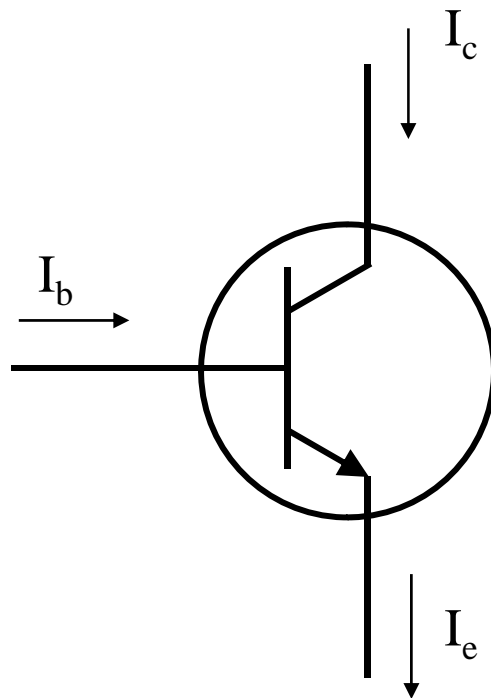

- E-B forward bias ($V_b > V_e$)
- C-B reverse bias ($V_c > V_b$)
- $I_{ce} = 100 I_{be} = \beta I_{be}$

All of chapter 3 is about calculating β .

Many current components

- Electron drift E-B
- Electron diffusion E-B
- Hole drift E-B
- Hole diffusion E-B
- Electron drift C-B
- Electron diffusion C-B
- Hole drift C-B
- Hole diffusion C-B

concentrate on these components, since they are the largest (Discuss why others small.)

“Normal active” band diagram

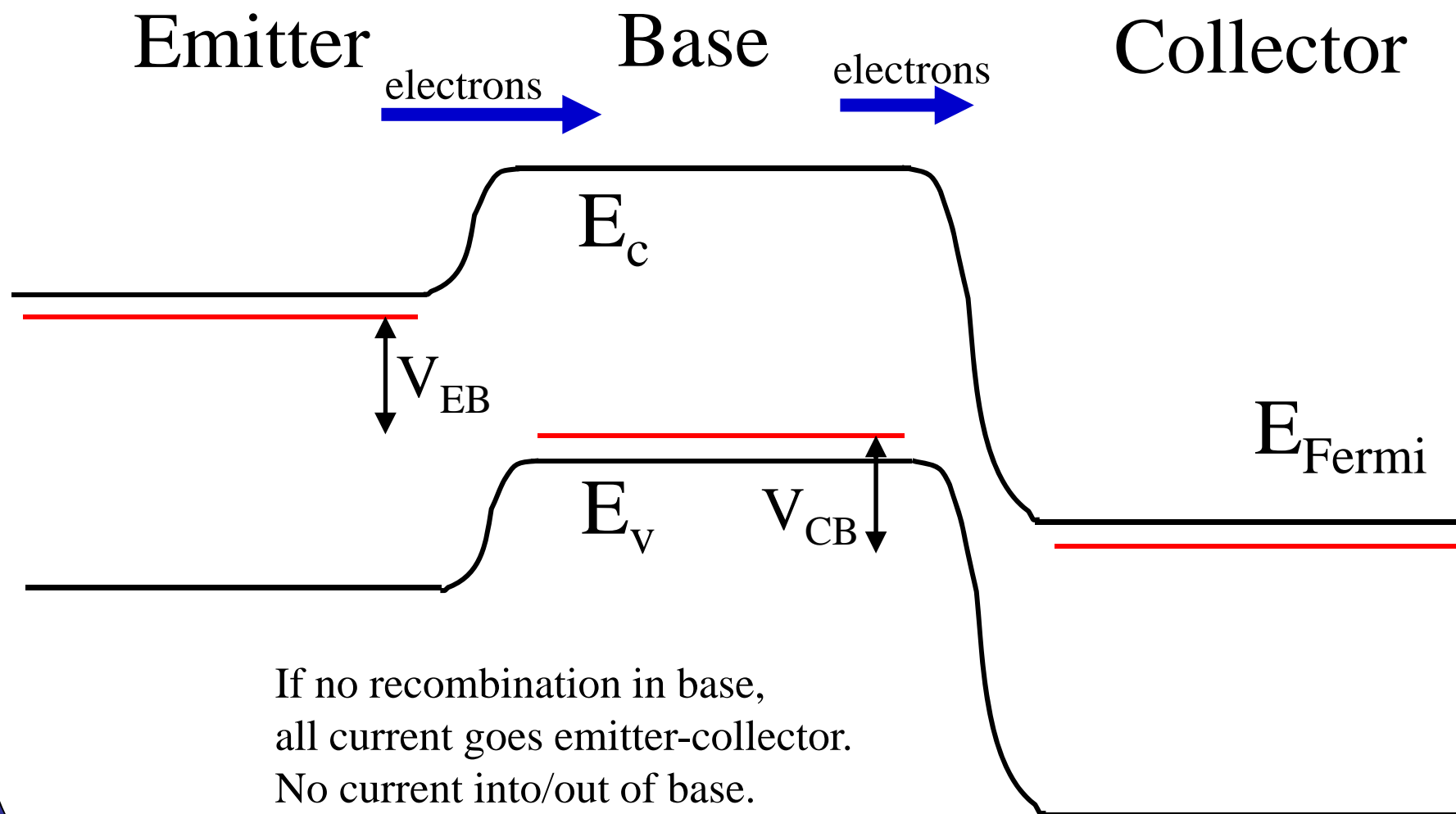

“Normal active” band diagram

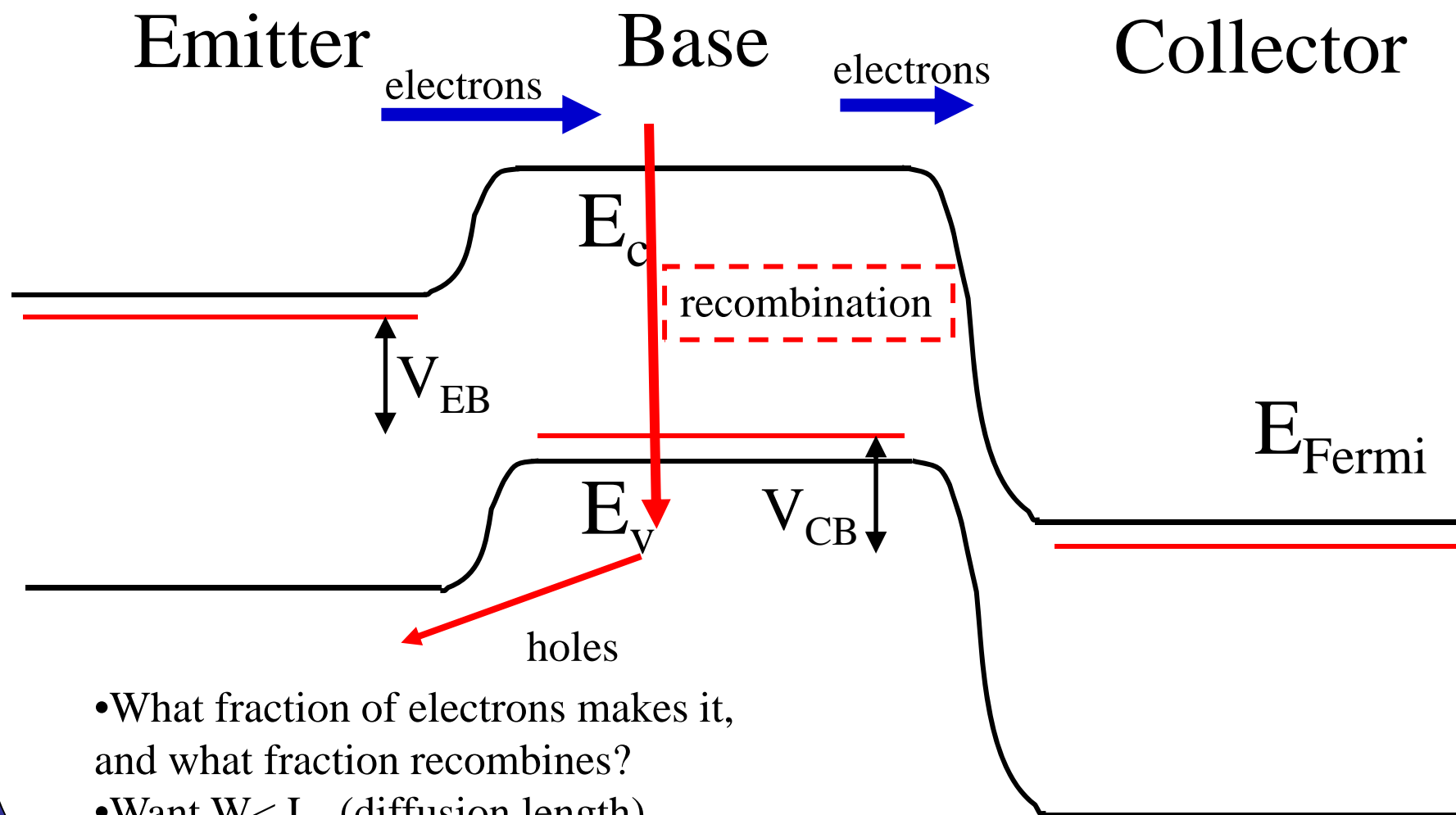

- What fraction of electrons makes it, and what fraction recombines?
- Want $W < L_n$ (diffusion length)
- Holes from B-E cause base current.

“Normal active” schematic

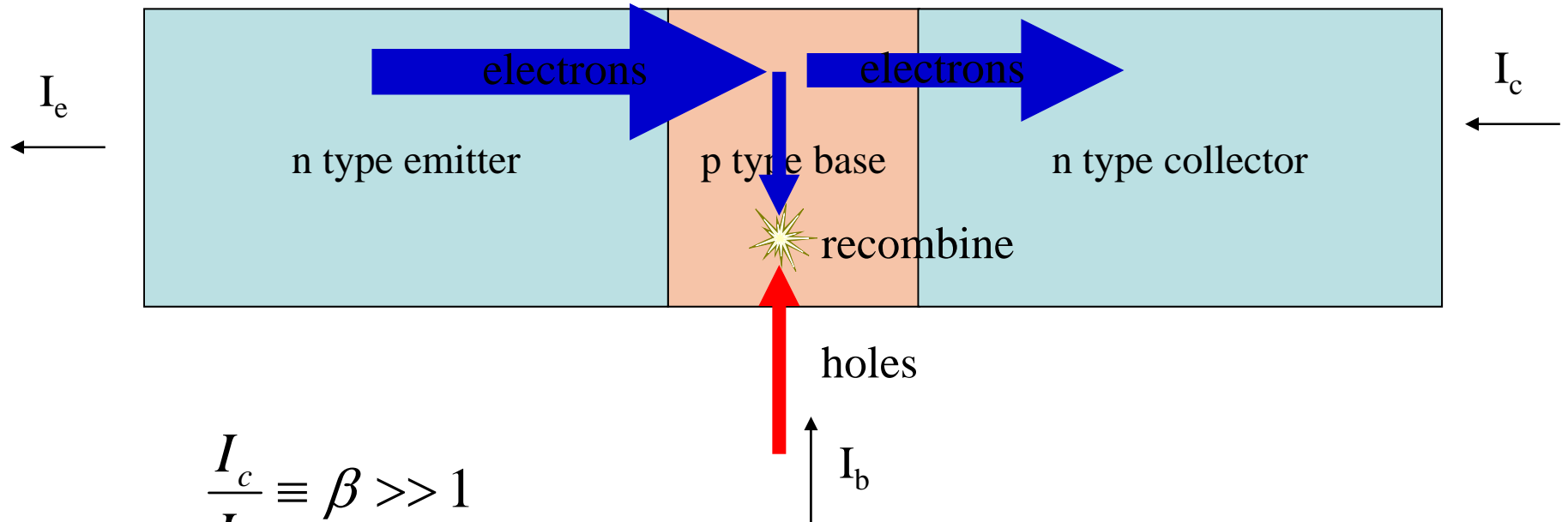

$$\frac{I_c}{I_b} \equiv \beta \gg 1$$

$$\frac{I_c}{I_b} \approx \frac{\tau_n}{\tau_t}$$

$\tau_t \equiv$ transit time (discuss drunken man analogy)

“Normal active” current gain

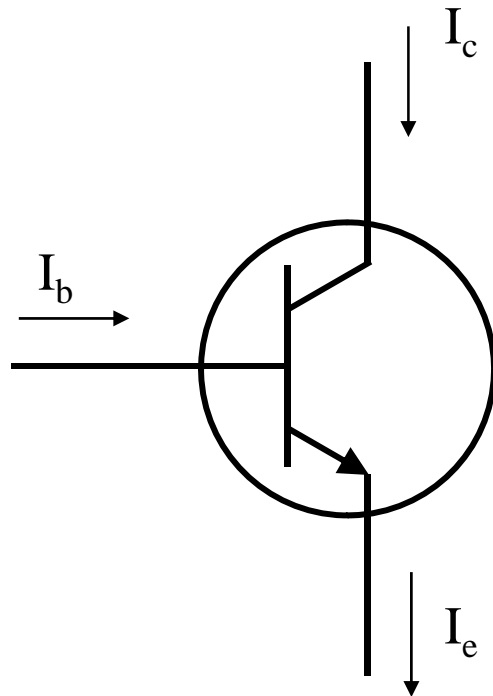

$$\frac{I_c}{I_b} \equiv \beta \gg 1$$

That is simplest circuit model. It just gets more complicated from here!

“Normal active” schematic

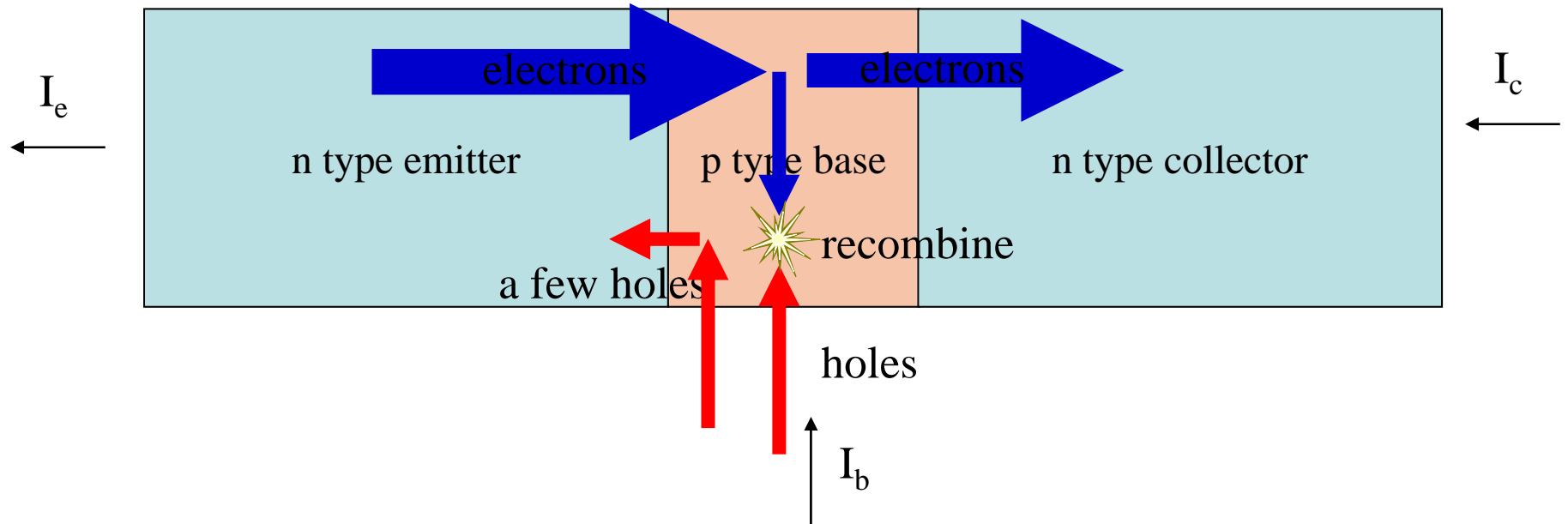

Goal: Find relationship between I_b , I_c

“Normal active” schematic

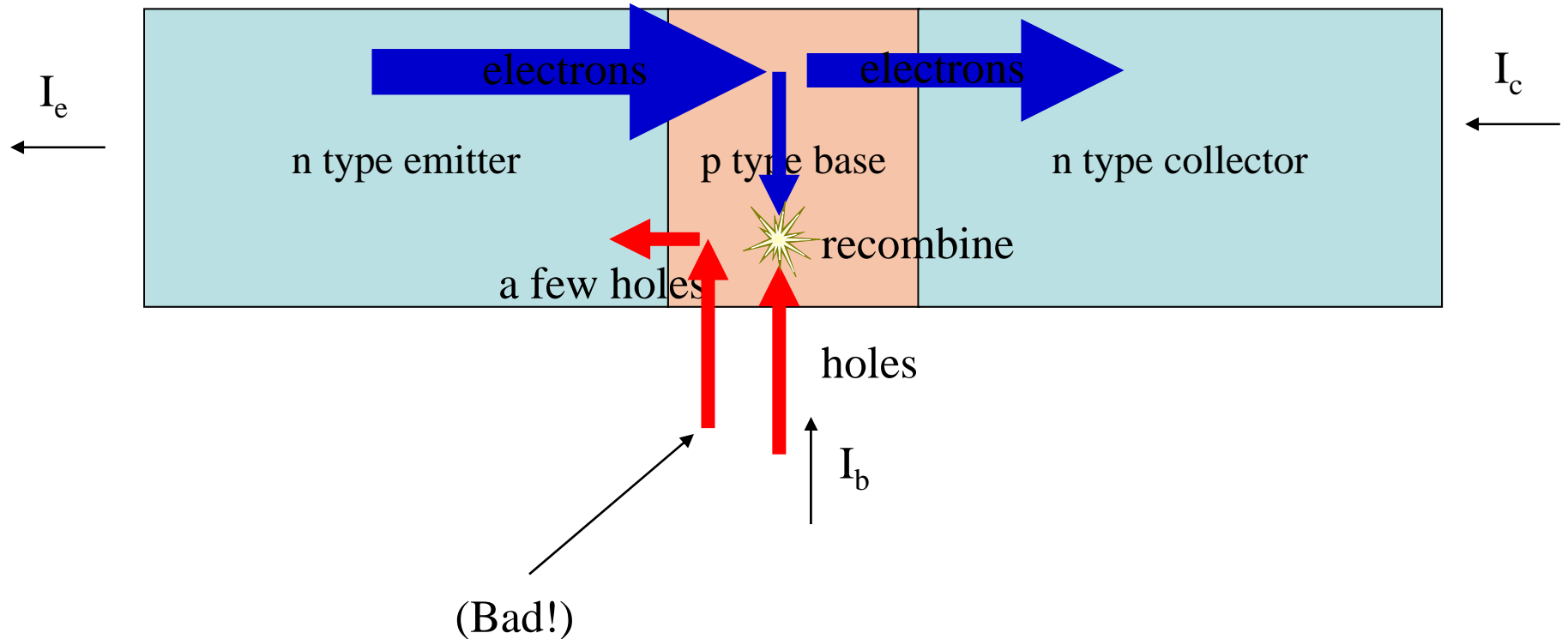

- Want low p-type doping.
- Can show need $n > p$
- But $n > p$ bad for base resistance (speed)
- Solution later: heterojunctions block p injection into emitter
- HBTs can have $p > n$ good for speed

“Normal active” schematic

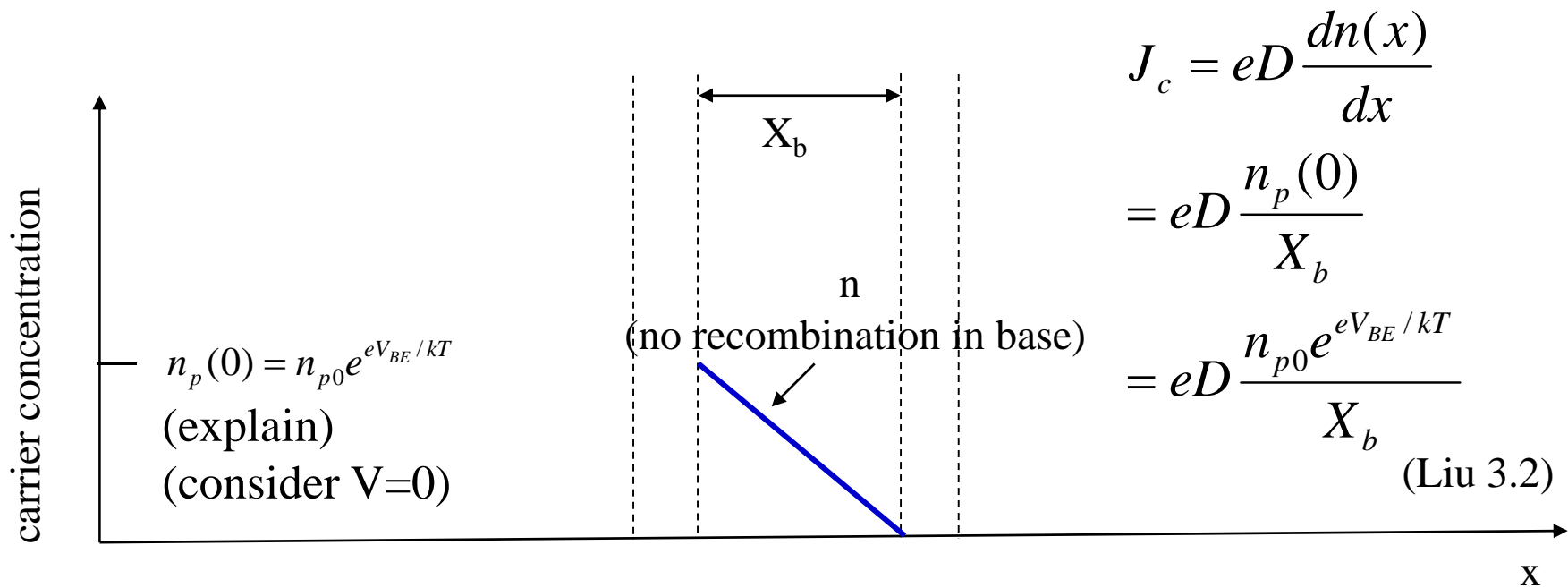
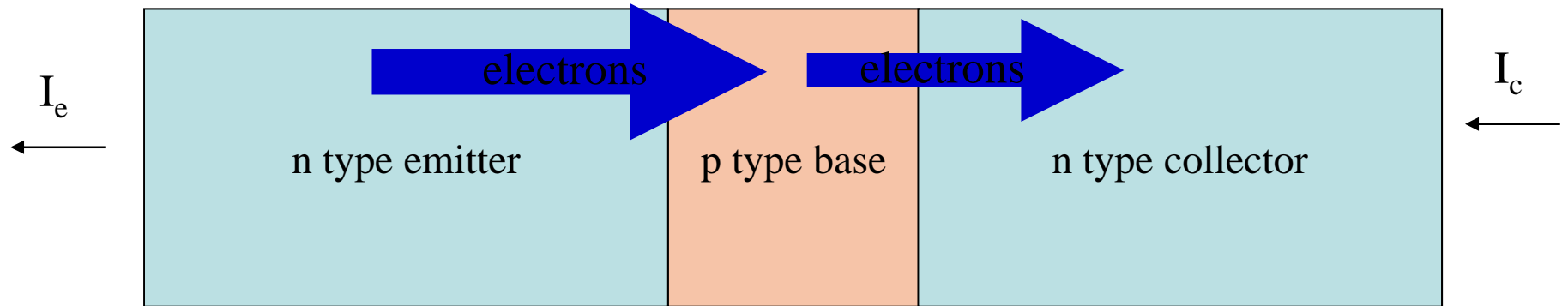

Discuss J vs. I. Discuss line vs. tanh.

“Normal active” schematic

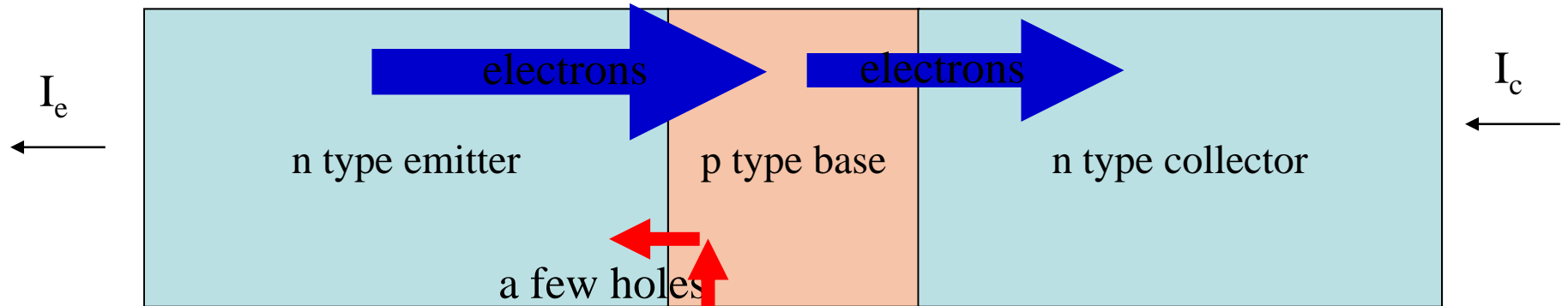

$$J_{B_p} = eD \frac{p_{n0} e^{eV_{BE}/kT}}{L_p}$$

(explain like HW#1)

Liu equation 3.1

“Normal active” schematic

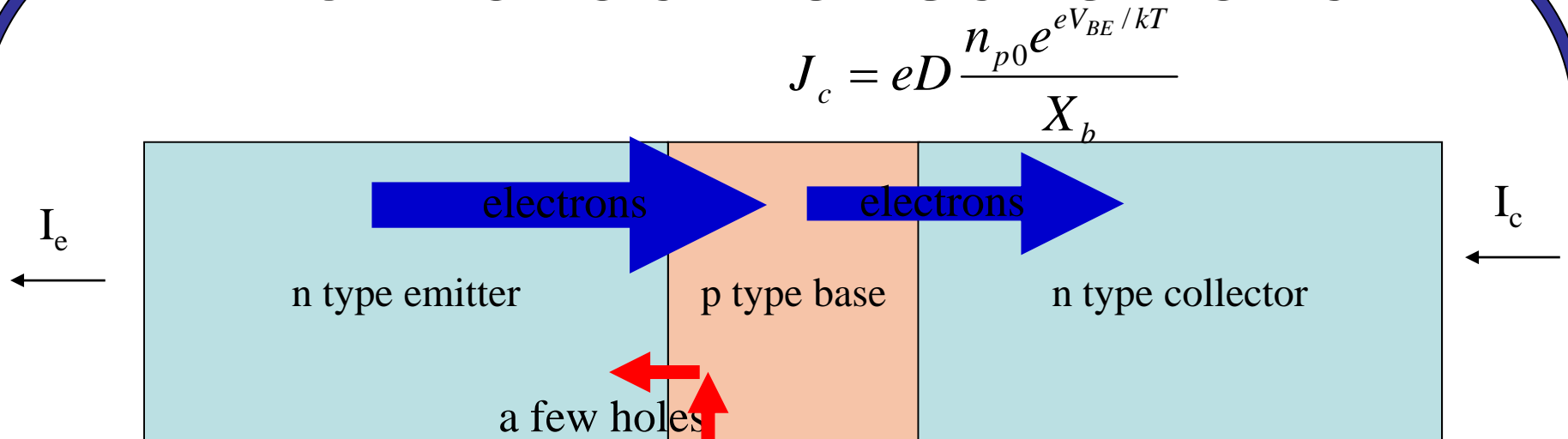

$$J_c = eD \frac{n_{p0} e^{eV_{BE}/kT}}{X_b}$$

$$J_{B_p} = eD \frac{p_{n0} e^{eV_{BE}/kT}}{L_p}$$

$$\frac{I_c}{I_b} \equiv \beta = \frac{eD \frac{n_{p0} e^{eV_{BE}/kT}}{X_b}}{eD \frac{p_{n0} e^{eV_{BE}/kT}}{L_p}} = \frac{n_{p0}}{p_{n0}} \frac{L_p}{X_b} ??? \gg 1$$

Need $n_{p0} \gg p_{n0}$

Bad for base resistance. Bad for E-B capacitance. So bad for speed.

“Normal active” HBT

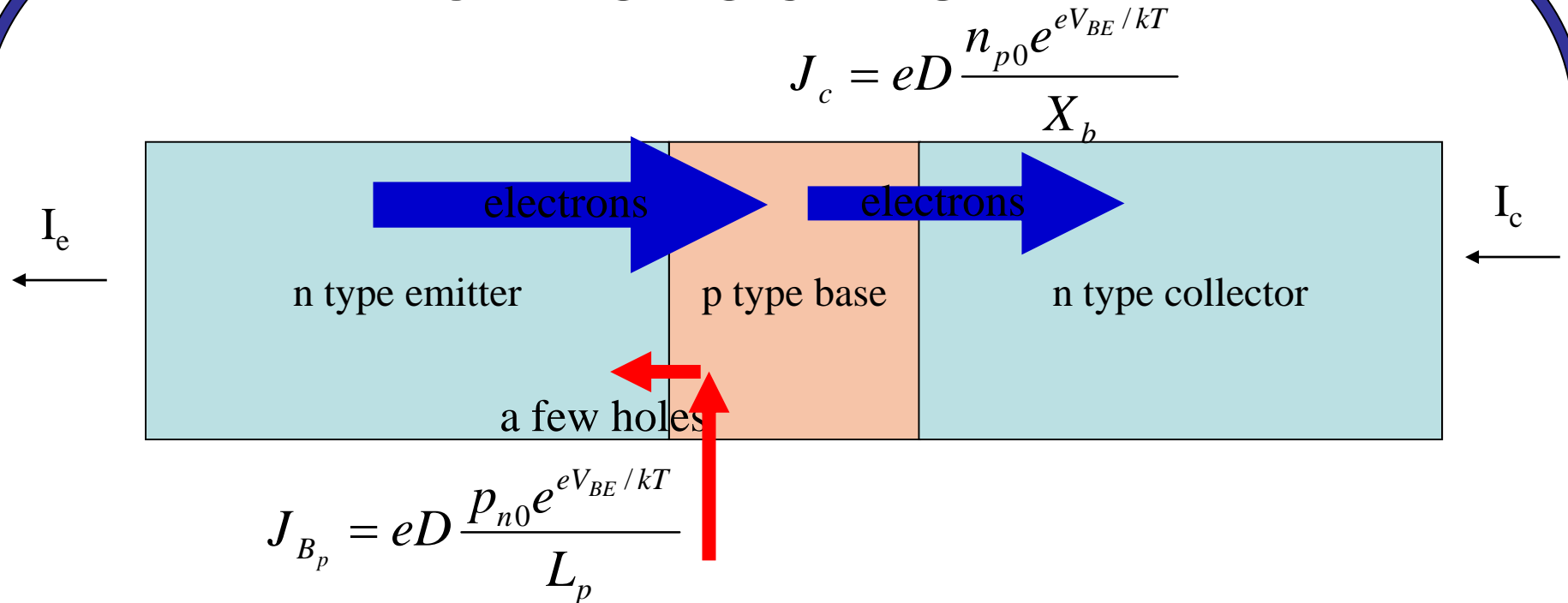

Holes exponentially suppressed if emitter is wider gap. (Graded.)

$$\frac{I_c}{I_b} \equiv \frac{n_{p0}}{p_{n0}} \frac{L_p}{X_b} e^{\Delta E_g/kT} \gg 1$$

Don't need $n_{p0} \gg p_{n0}$

Good for speed. Claims of 1 THz f_T in literature.

“Normal active” schematic

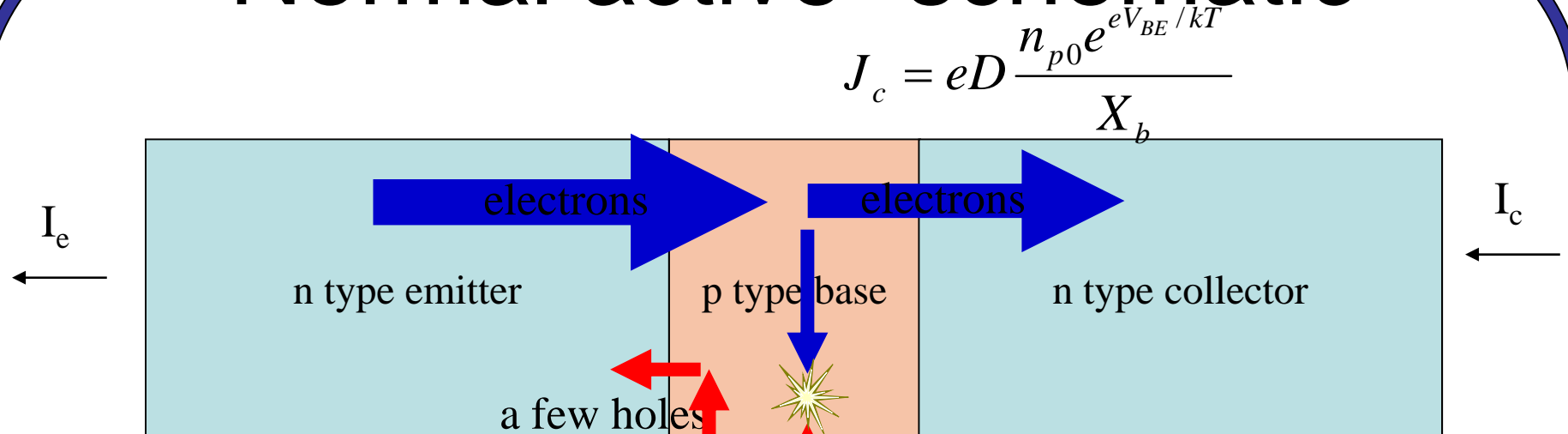

$$J_c = eD \frac{n_{p0} e^{eV_{BE}/kT}}{X_b}$$

$$J_{Bp} = eD \frac{p_{n0} e^{eV_{BE}/kT}}{L_p}$$



Depends on recombination processes in:

1. Surface (not contact)
2. Surface (at base contact)
3. Bulk
4. Space charge region

Try to minimize 1,2,4.

“Normal active” schematic

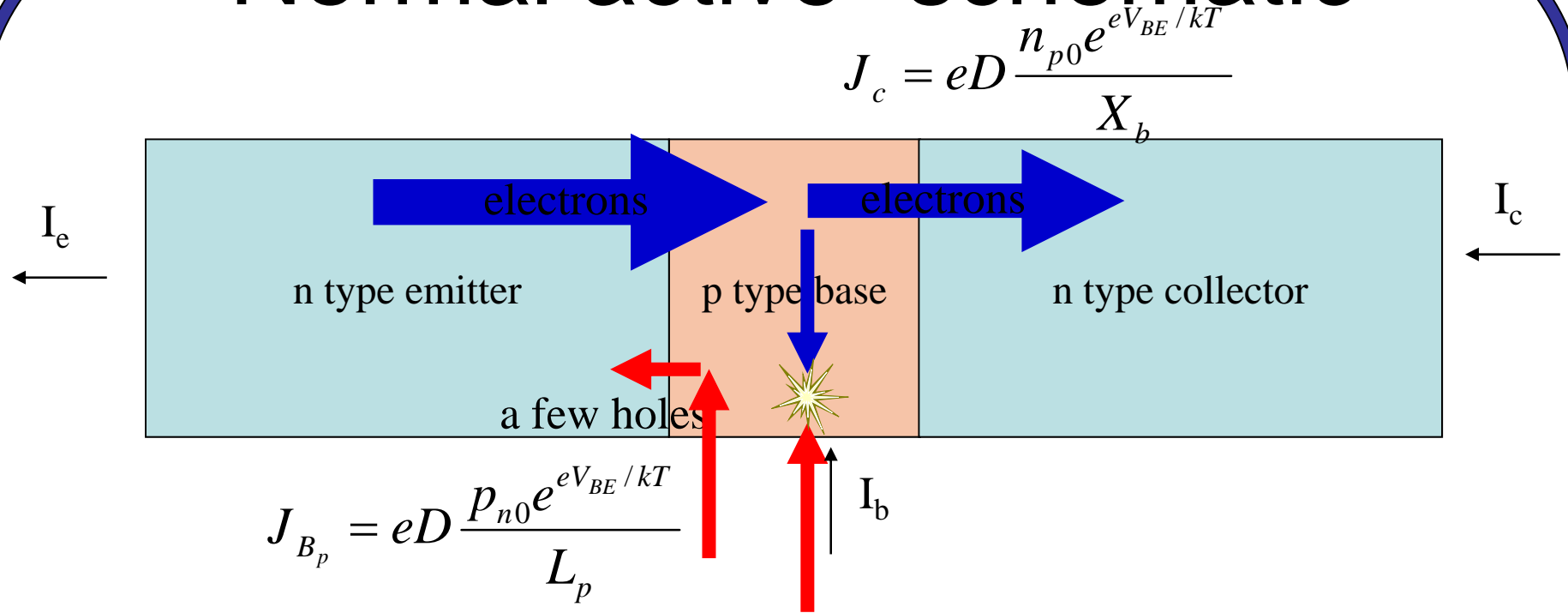

How to calculate:

Don't use line for $n(x)$ but tanh.

dn/dx em. – dn/dx coll = base curr.

Explain on board. Will be HW#3.

$$J_{Brec.} = e \frac{W n_{p0} e^{eV_{BE}/kT}}{2\tau_B} = eD \frac{n_{p0} e^{eV_{BE}/kT}}{X_B}$$

“Normal active” schematic

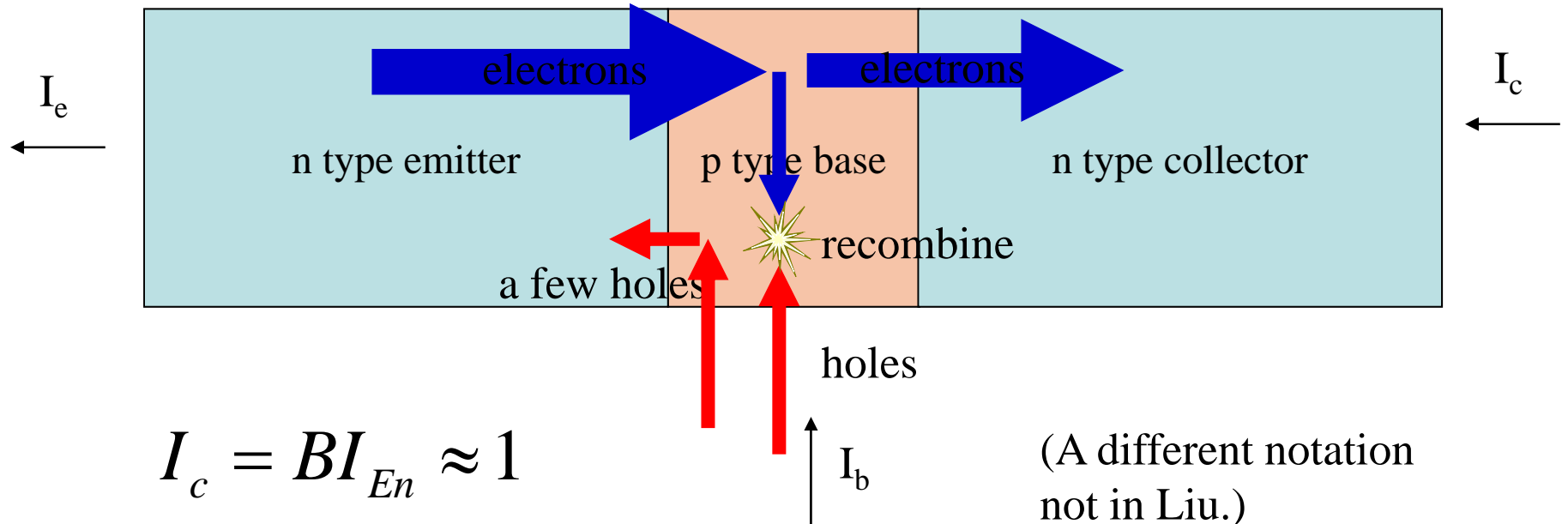

$$I_c = BI_{En} \approx 1$$

$$\gamma \equiv \frac{I_{En}}{I_{Ep} + I_{En}} \approx 1$$

$$\frac{I_c}{I_E} = \frac{I_c}{I_{Ep} + I_{En}} = \frac{BI_{En}}{I_{Ep} + I_{En}} = \gamma B \equiv \alpha \approx 1$$

$$I_b = I_{Ep} + (1 - B)I_{En}$$

$$\frac{I_c}{I_b} = \frac{BI_{En}}{I_{Ep} + (1 - B)I_{En}} = \frac{\alpha}{1 - \alpha} \equiv \beta \gg 1$$

Complications

- High power
- Spreading resistance

Equivalent circuit 1

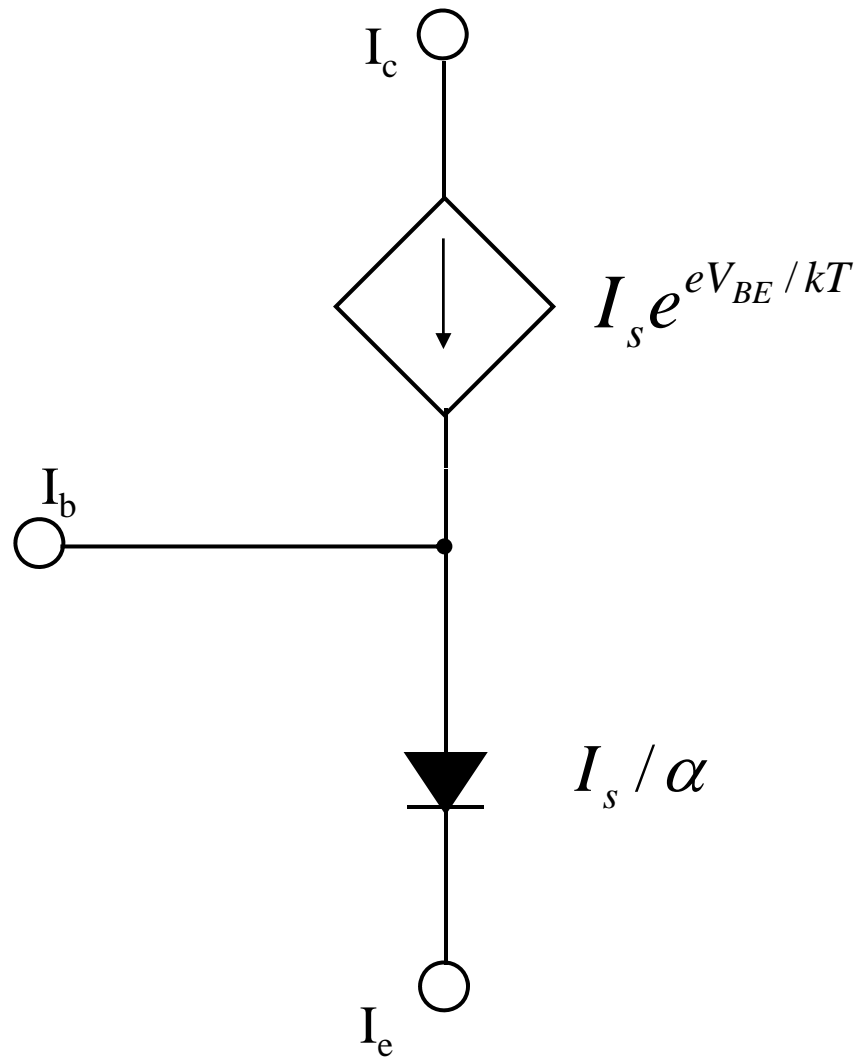

$$I_s \equiv \frac{AeDn_{po}}{X_B}$$

Equivalent circuit 2

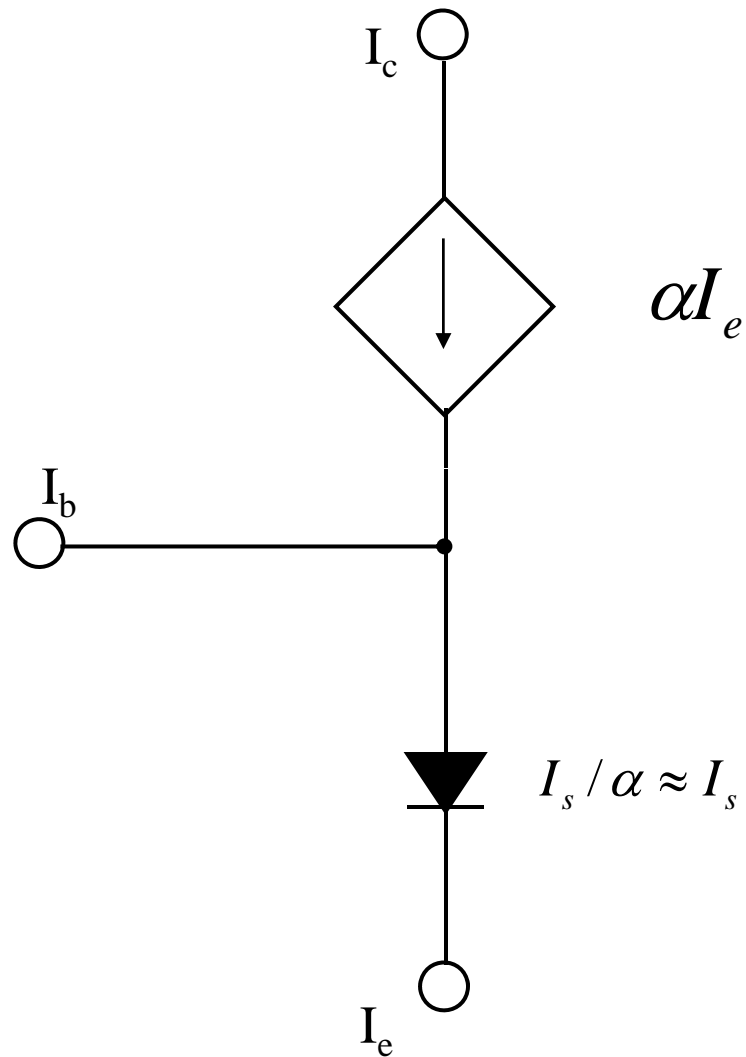

$$I_s \equiv \frac{AeDn_{po}}{X_B}$$

Equivalent circuit 3

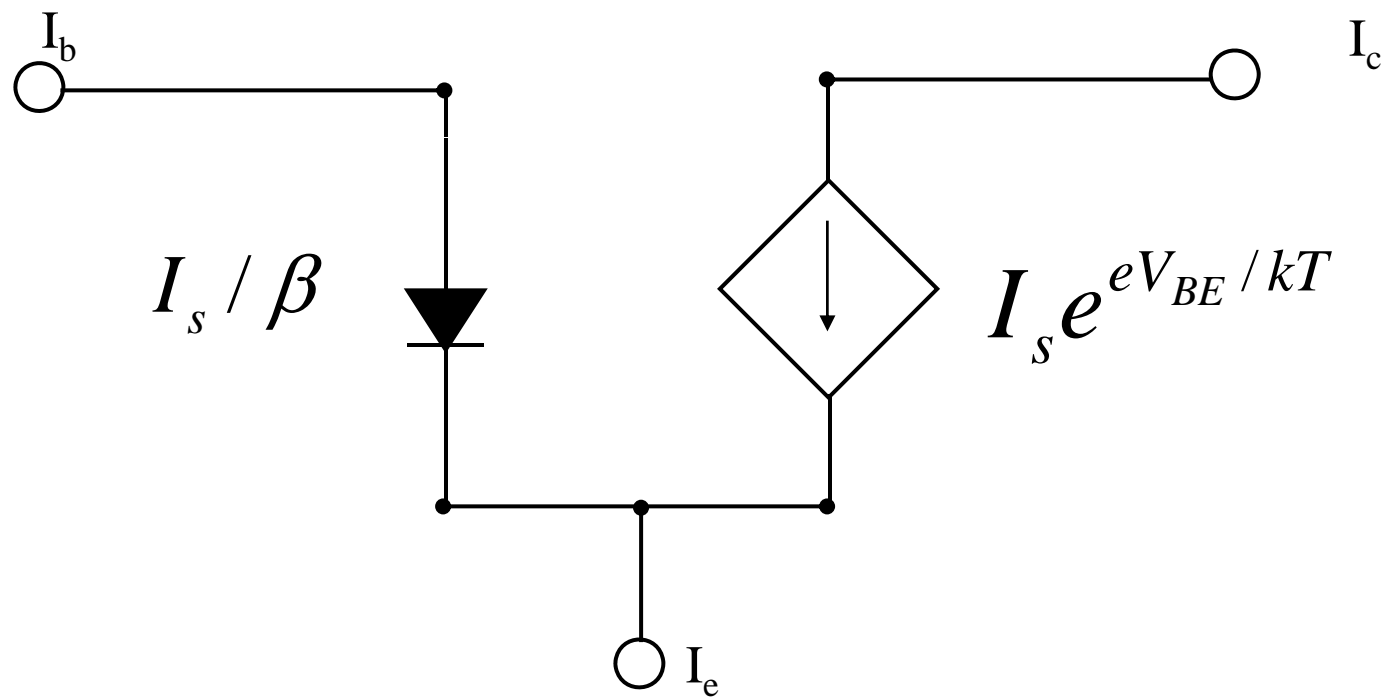

Equivalent circuit 4

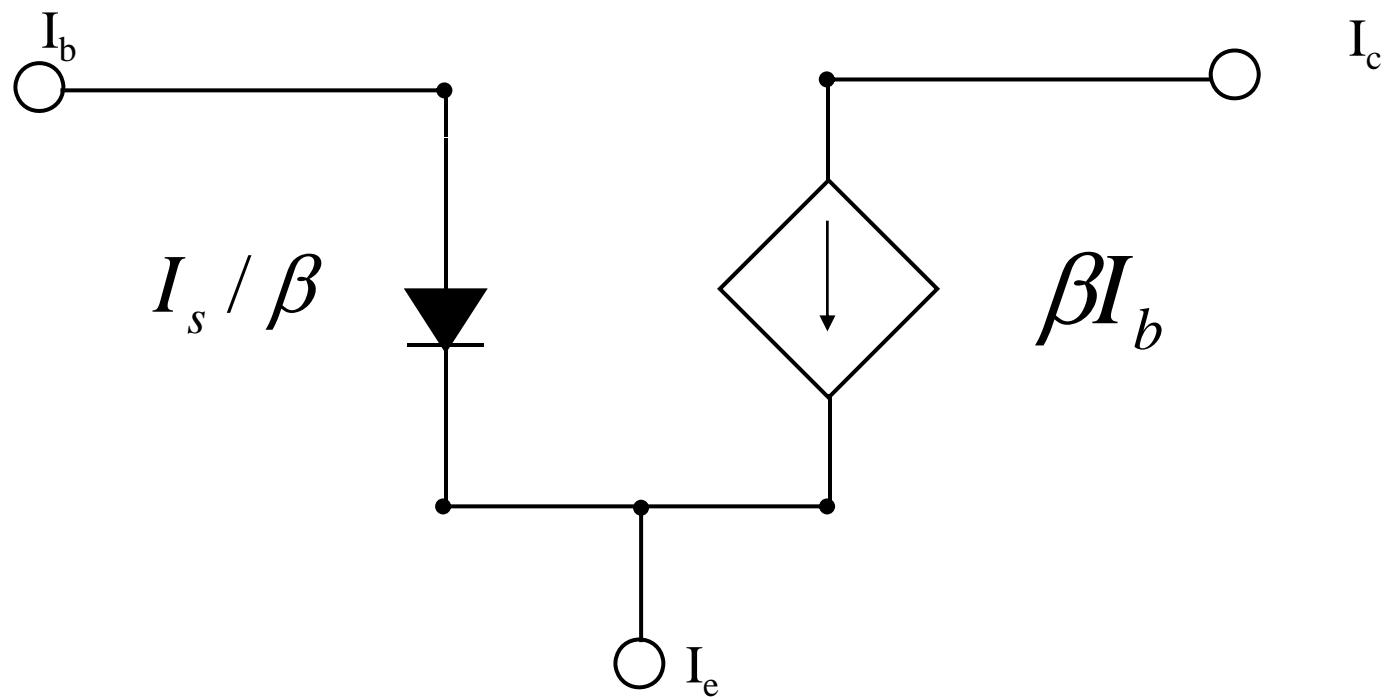

Early effect

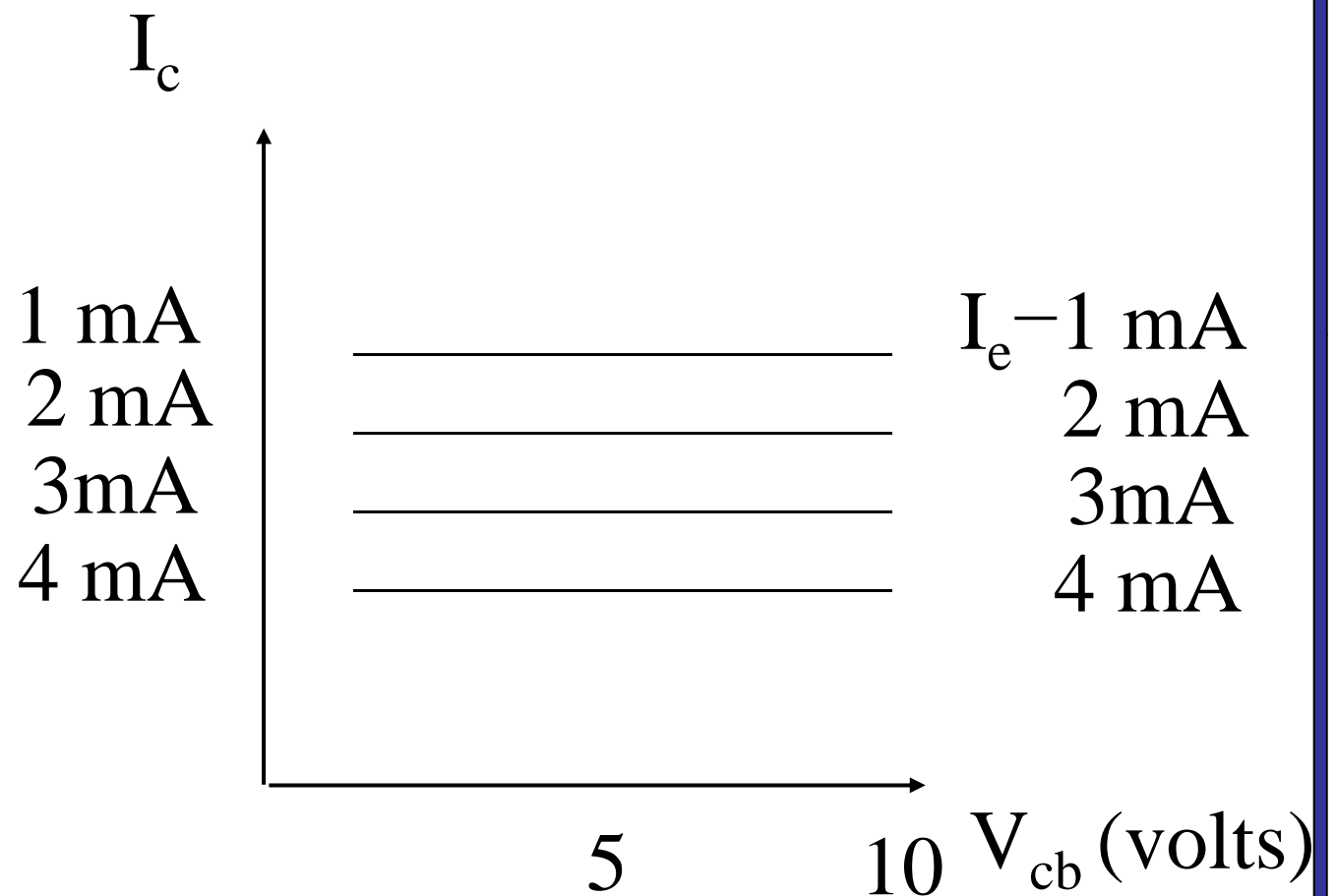

Early effect

$$\frac{I_c}{I_b} \equiv \beta \gg 1$$

$$\frac{I_c}{I_b} \approx \frac{\tau_n}{\tau_t}$$

1 mA
2 mA
3 mA
4 mA

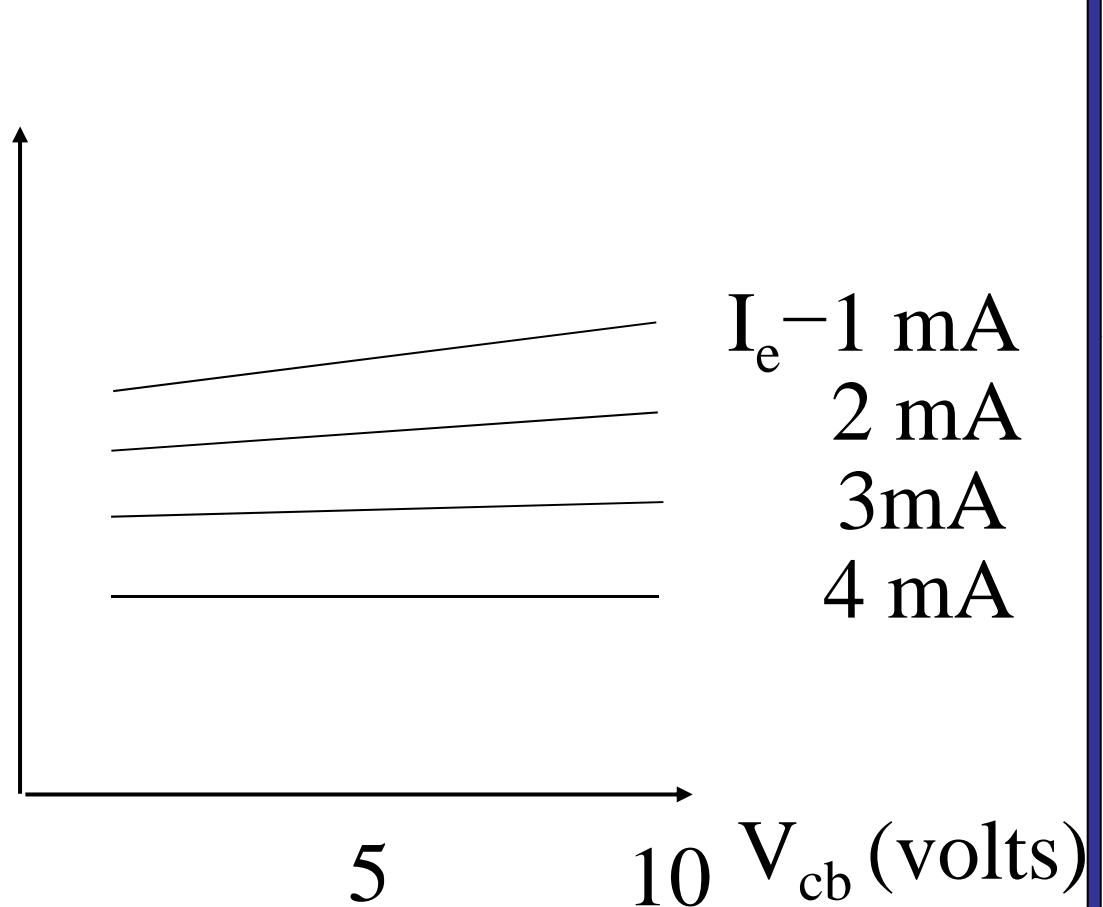

$I_e = 1$ mA
2 mA
3 mA
4 mA

Bipolar advantages

- Speed set by base width, which is easy to control
- Large area contributes to current, good for power

Bipolar dis-advantages

- Need base current at dc
- No easy complementary digital logic