

f_T vs f_{Max}

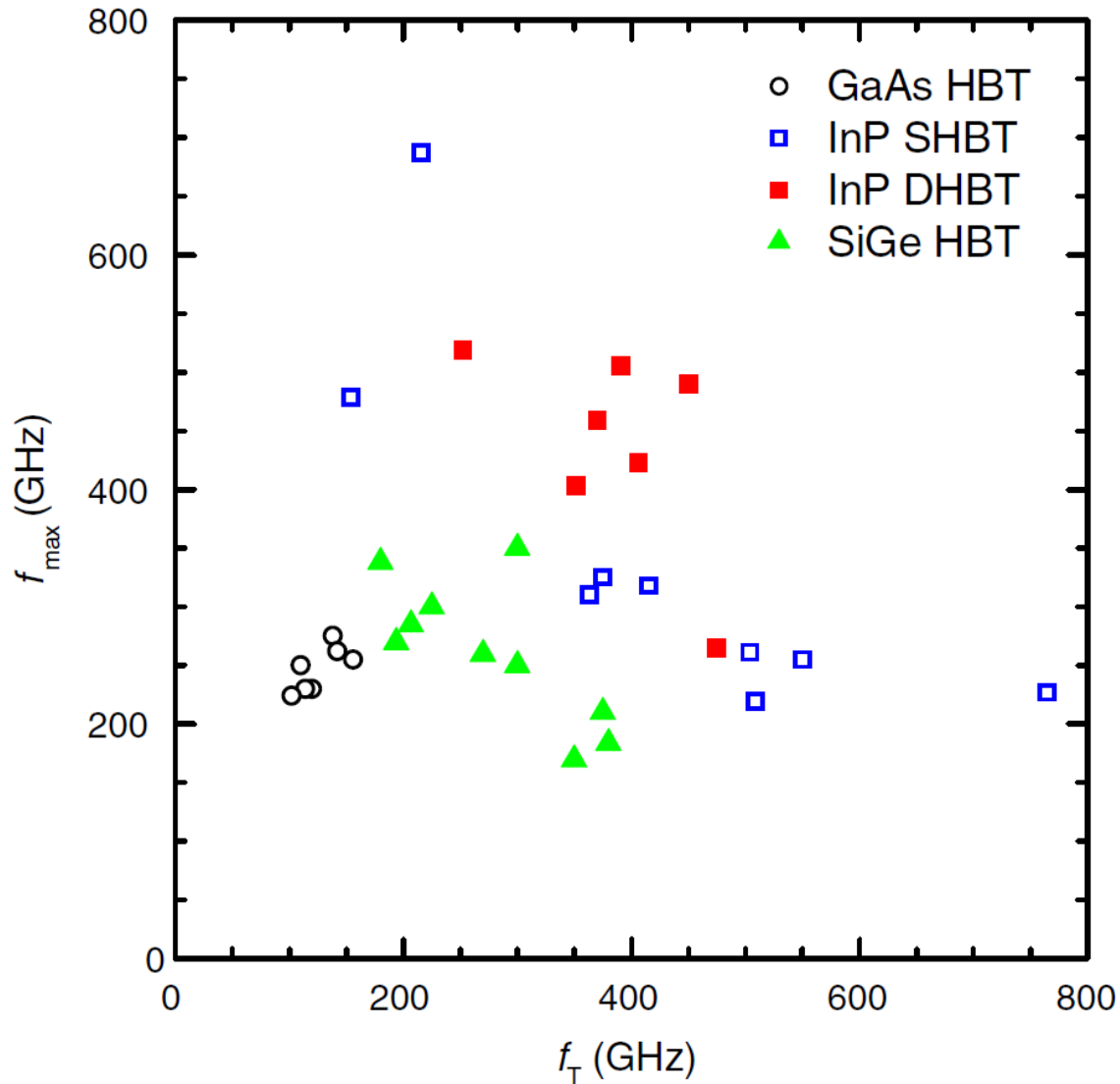

F. Schwierz and J. J. Liou, "RF Transistors: Recent Developments and Roadmap toward Terahertz Applications", *Solid-State Electronics*, **51**, 1079-1091, (2007).

Lecture 7: Field Effect Devices

- MOSFET
- JFET
- MESFET
- HEMT

Si MOSFET:

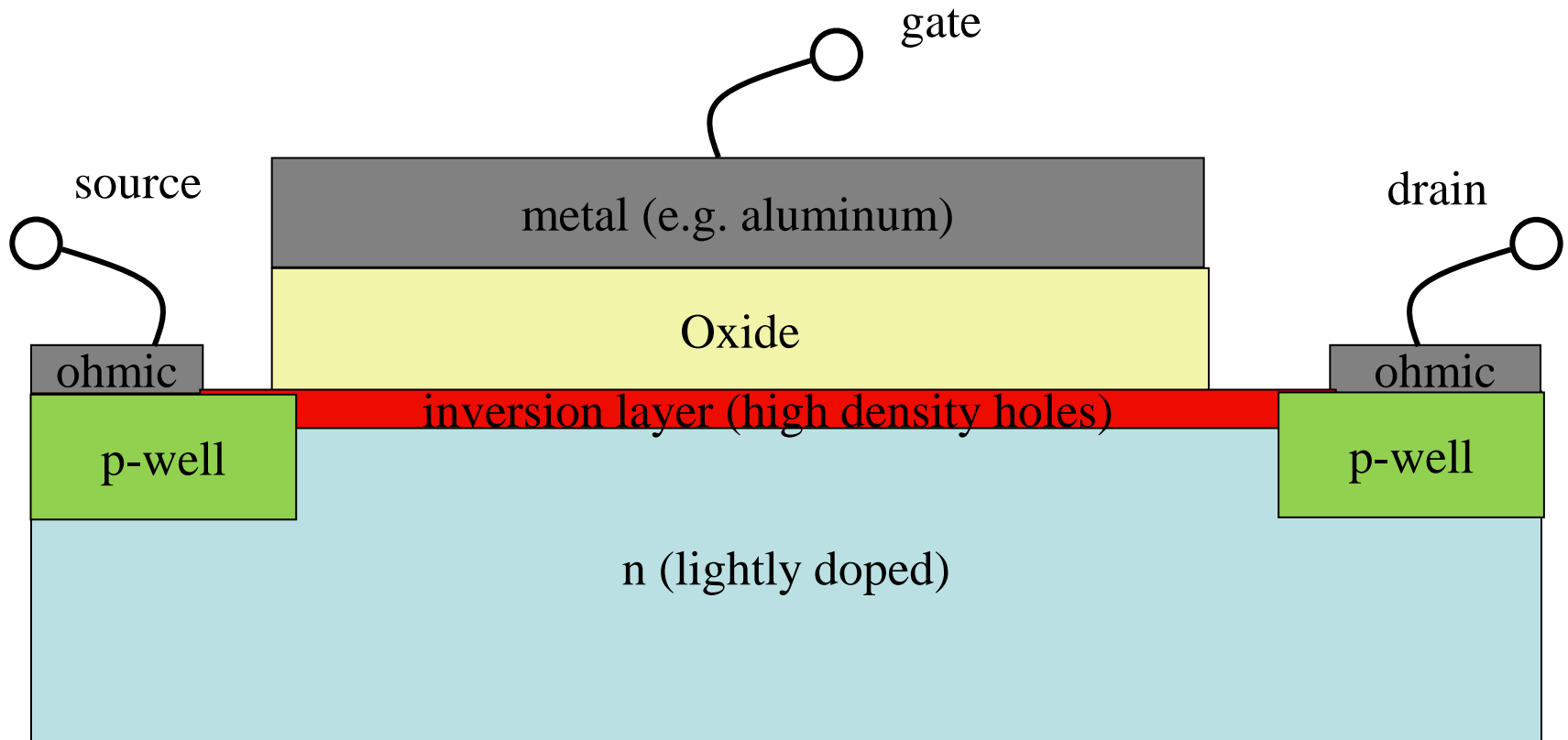

- Gate has high input resistance ($10^{12} \Omega$)
- Si covered in ECE 277A.
- No oxide for GaAs, so need different type of device.

Non-oxide transistors

- JFET: Junction Field Effect Transistor
- MESFET: Metal Electron Semiconductor Field Effect Transistor
- HEMT: High Electron Mobility Transistor
 - Also called:
 - MODFET Modulation Doped Field Effect Transistor
 - TEGFET Two-Dimensional Electron Gas Field Effect Transistor
 - pHEMT Pseudomorphic HEMT
 - HFET Heterojunction Field Effect Transistor

Electric field

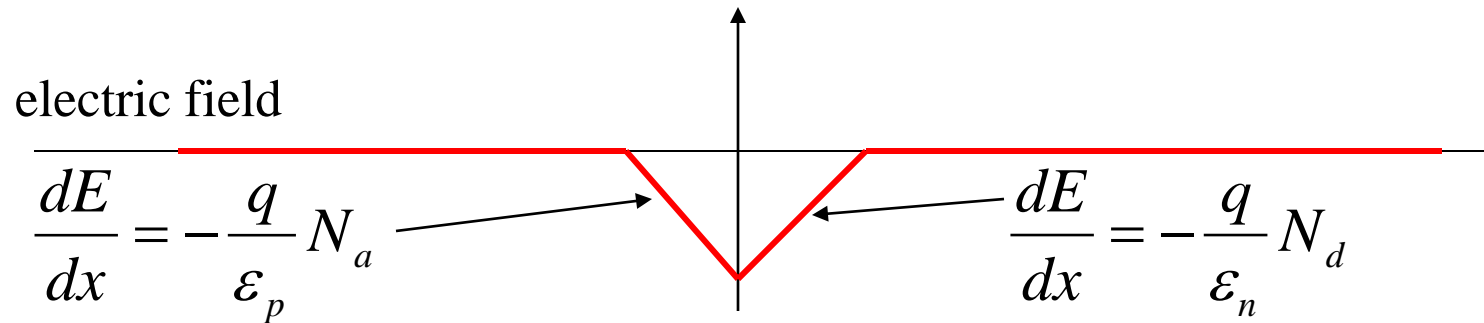
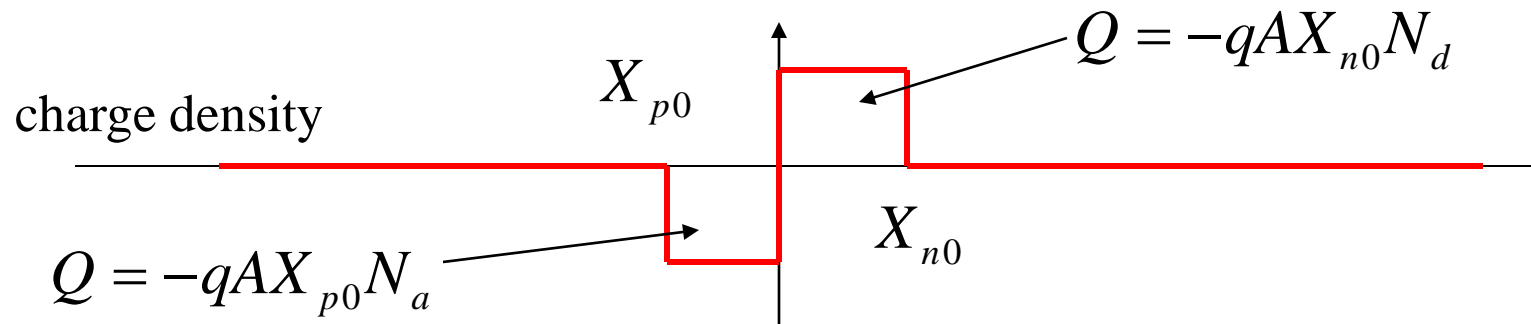

$$E(x) = -\frac{q}{\epsilon_p} N_a (x + X_{p0})$$

$$E(x) = -\frac{q}{\epsilon_p} N_d (X_{n0} - x)$$

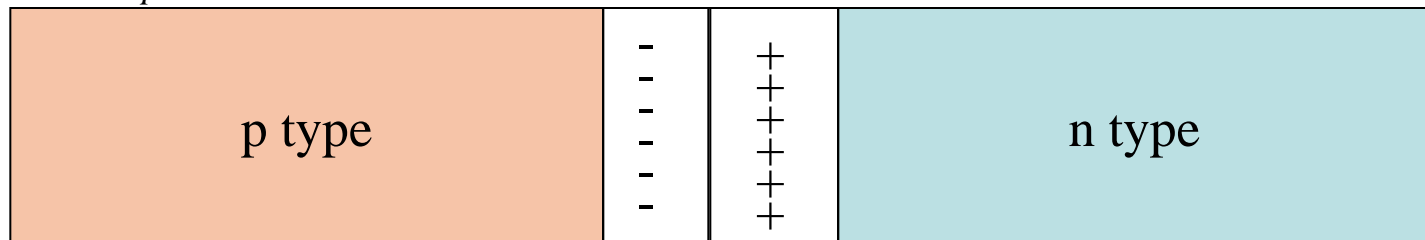

Under Bias:

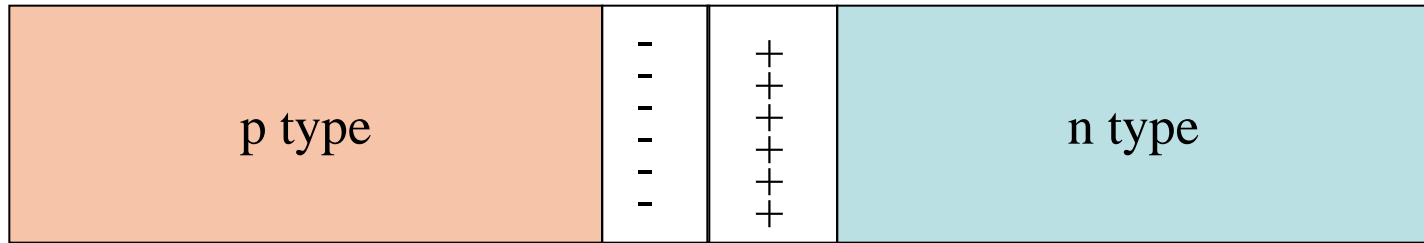
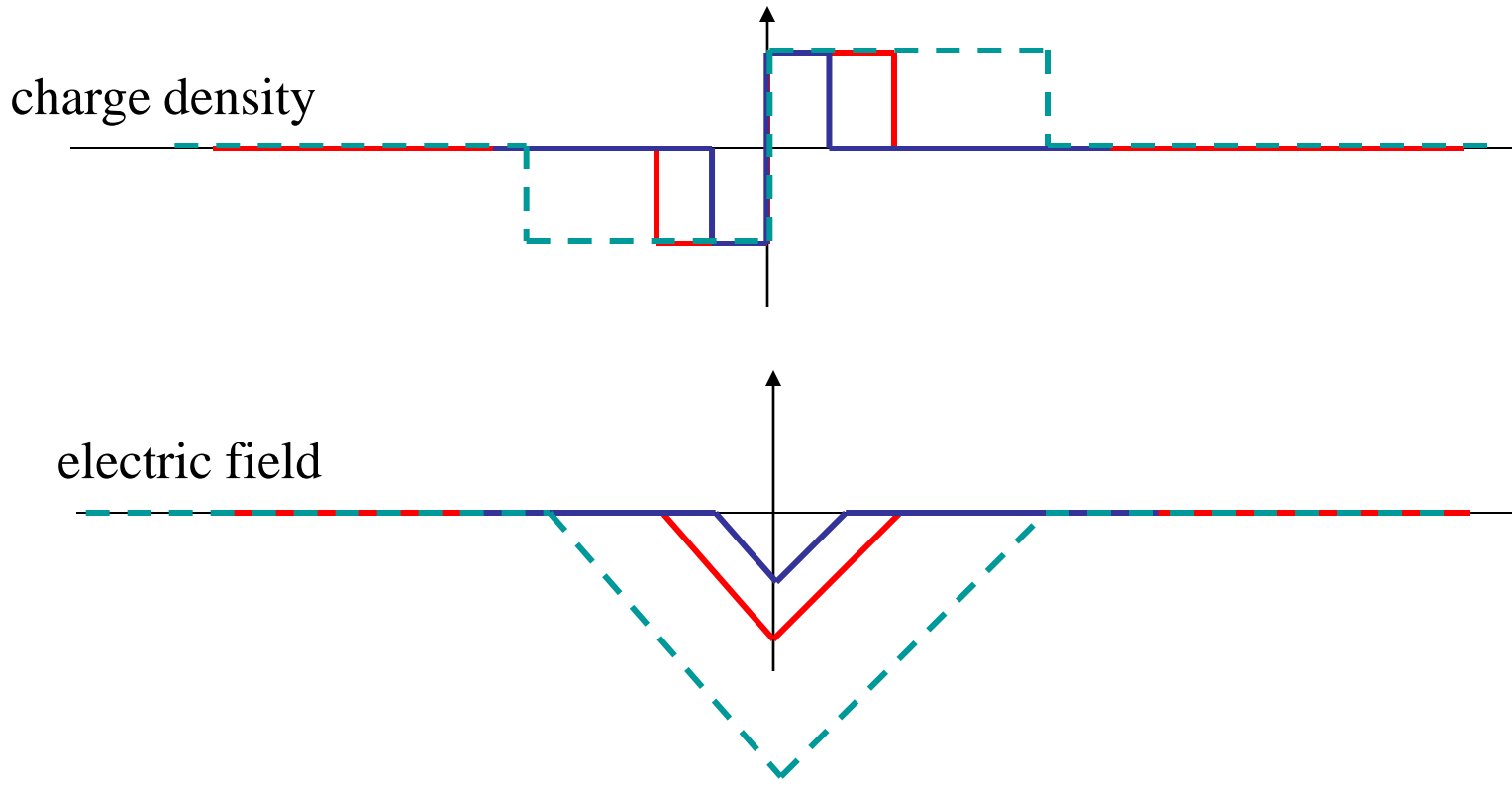

JFET:

- Like MOSFET, but no oxide
- Gate looks like diode: Don't forward bias!

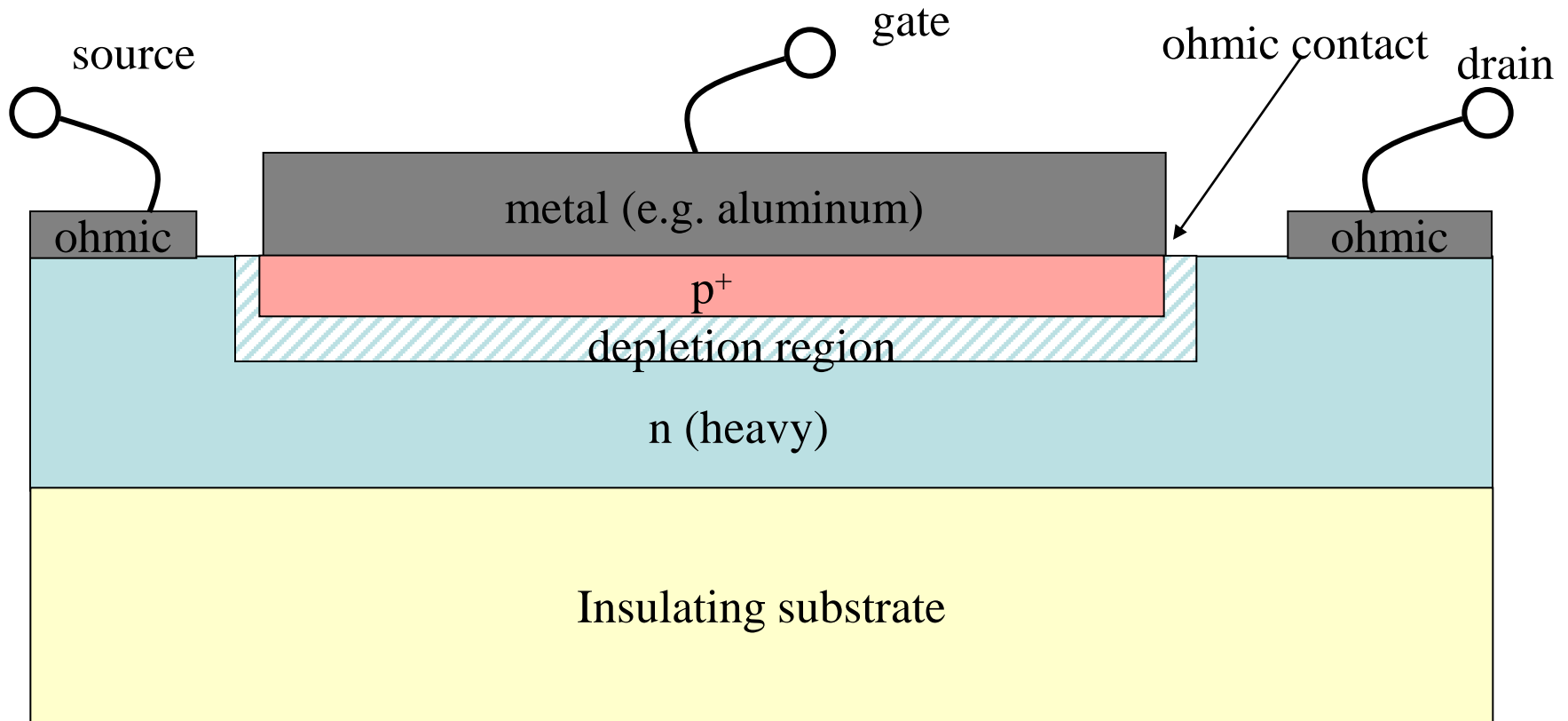

JFET:

$$V_{\text{gate}} = -5 \text{ V}$$

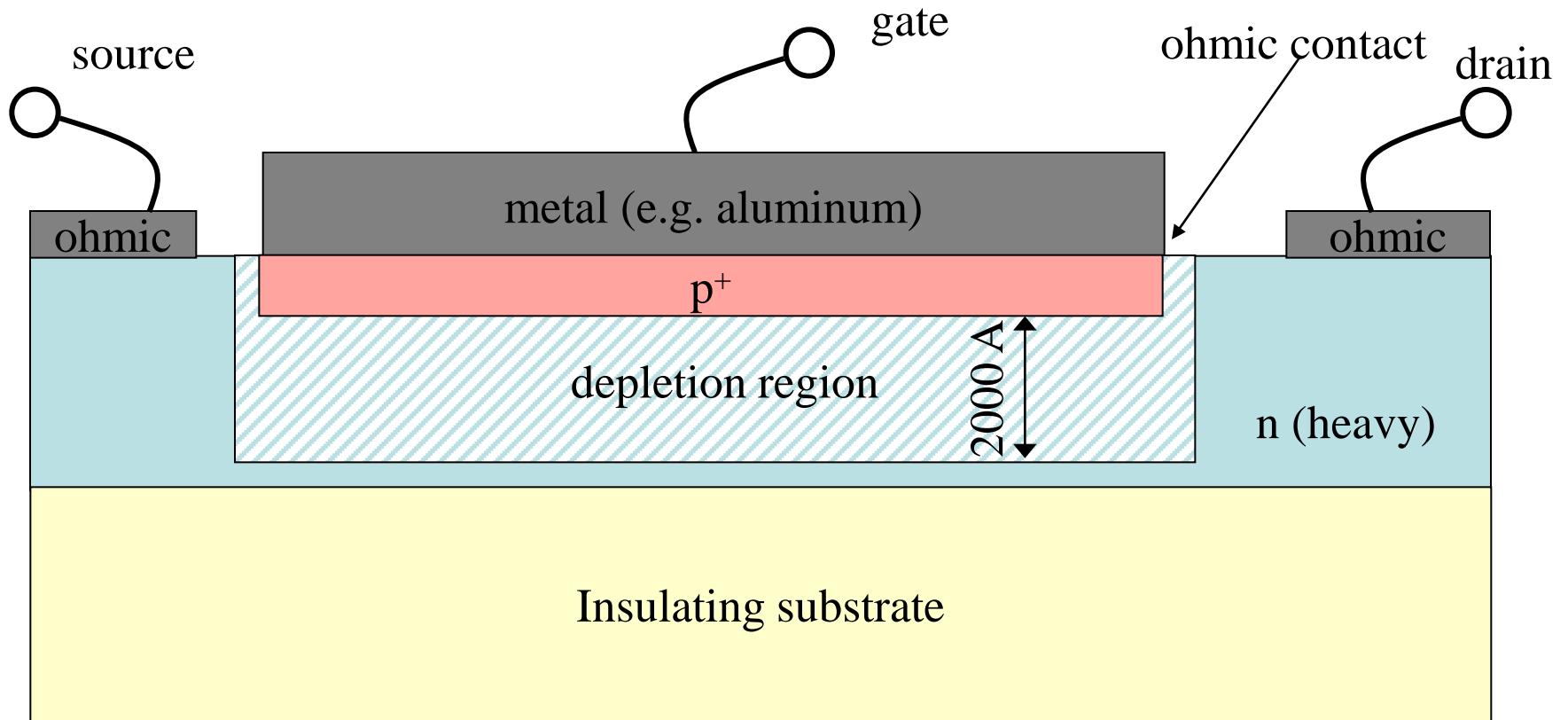

JFET:

$$V_{\text{gate}} = -5 \text{ V}$$
$$V_{\text{sd}} > 0$$

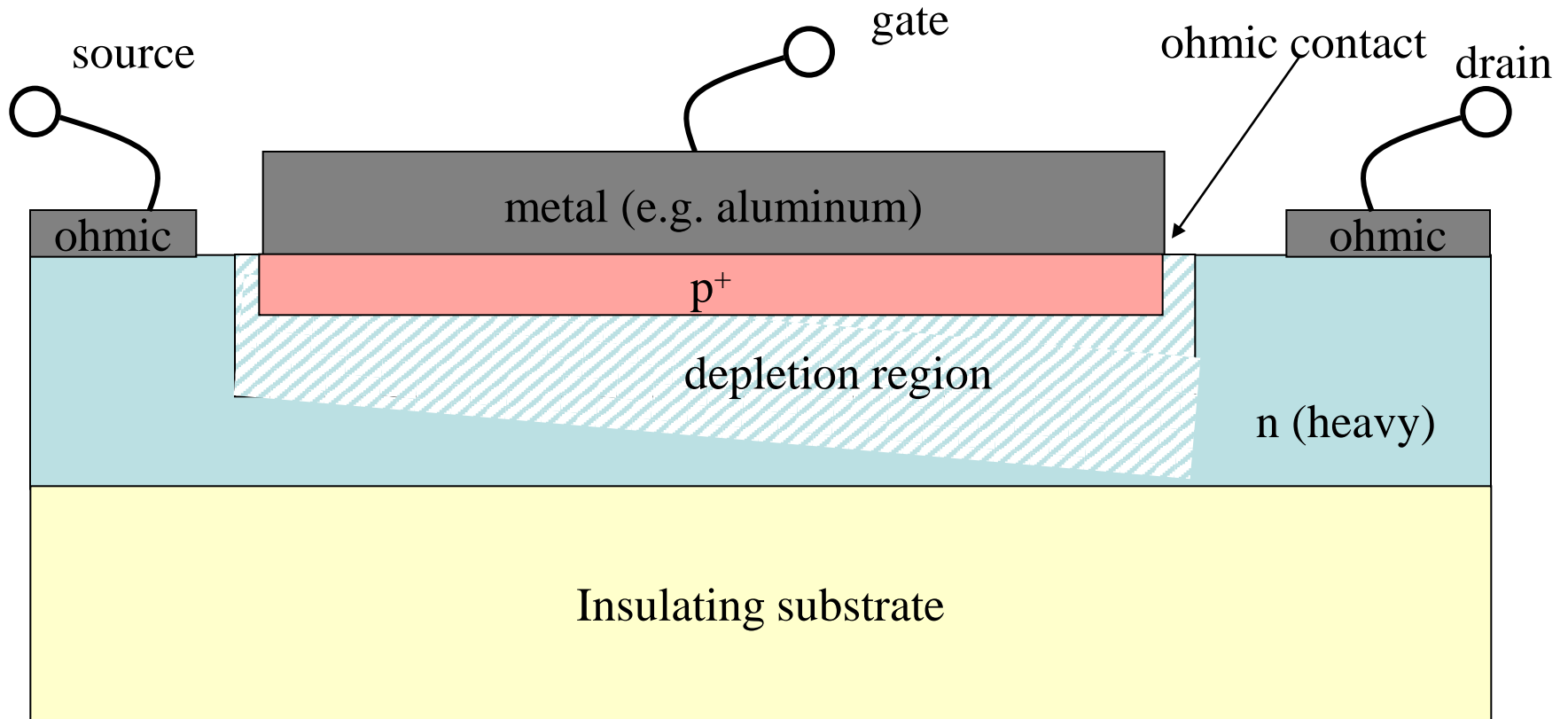

MESFET:

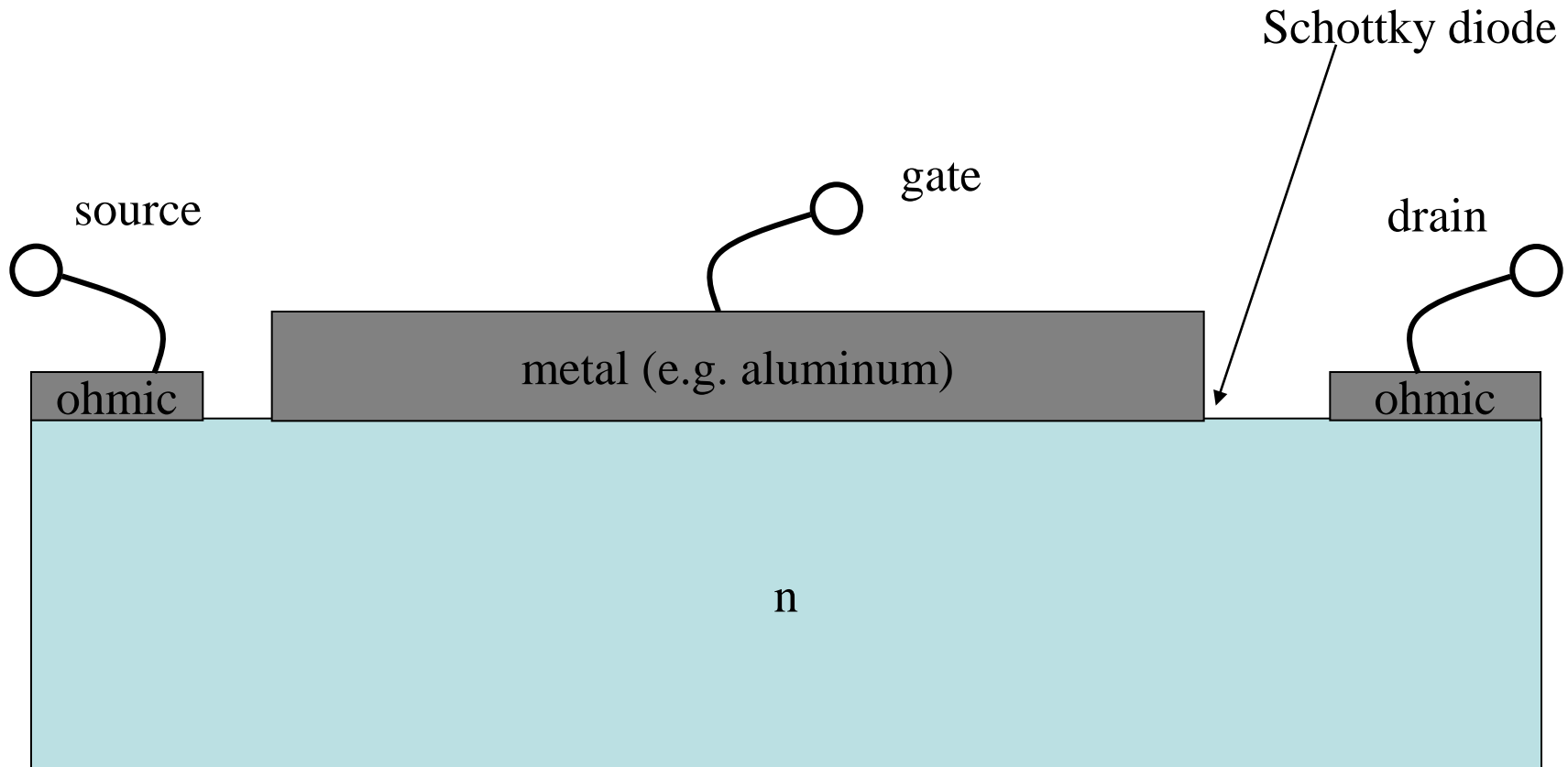

- Like MOSFET, but no oxide
- Gate looks like Schottky diode: Don't forward bias!

Schottky barriers

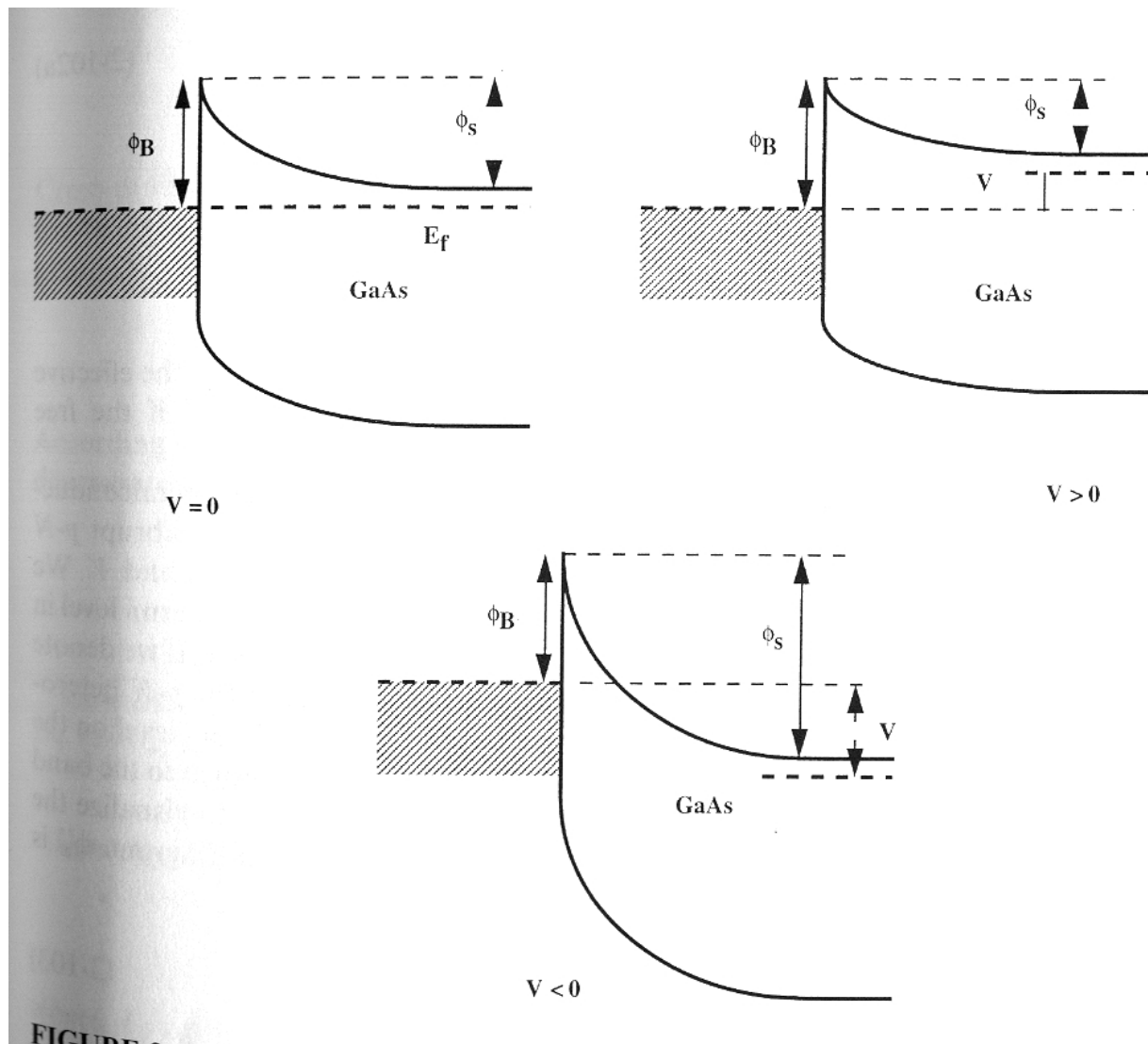

From Liu

Schottky depletion region

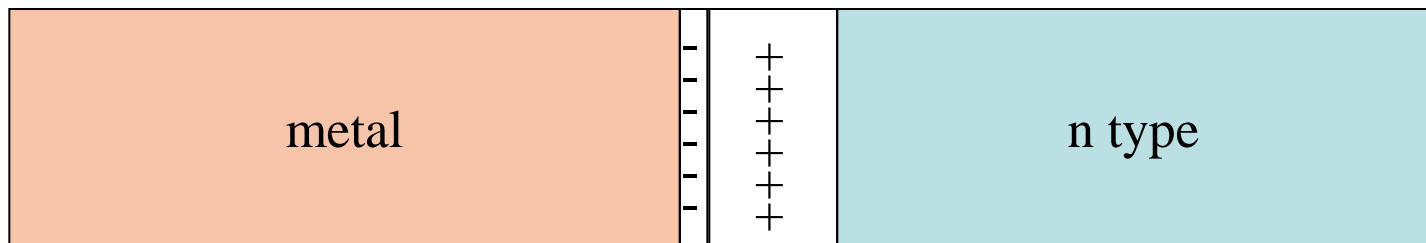
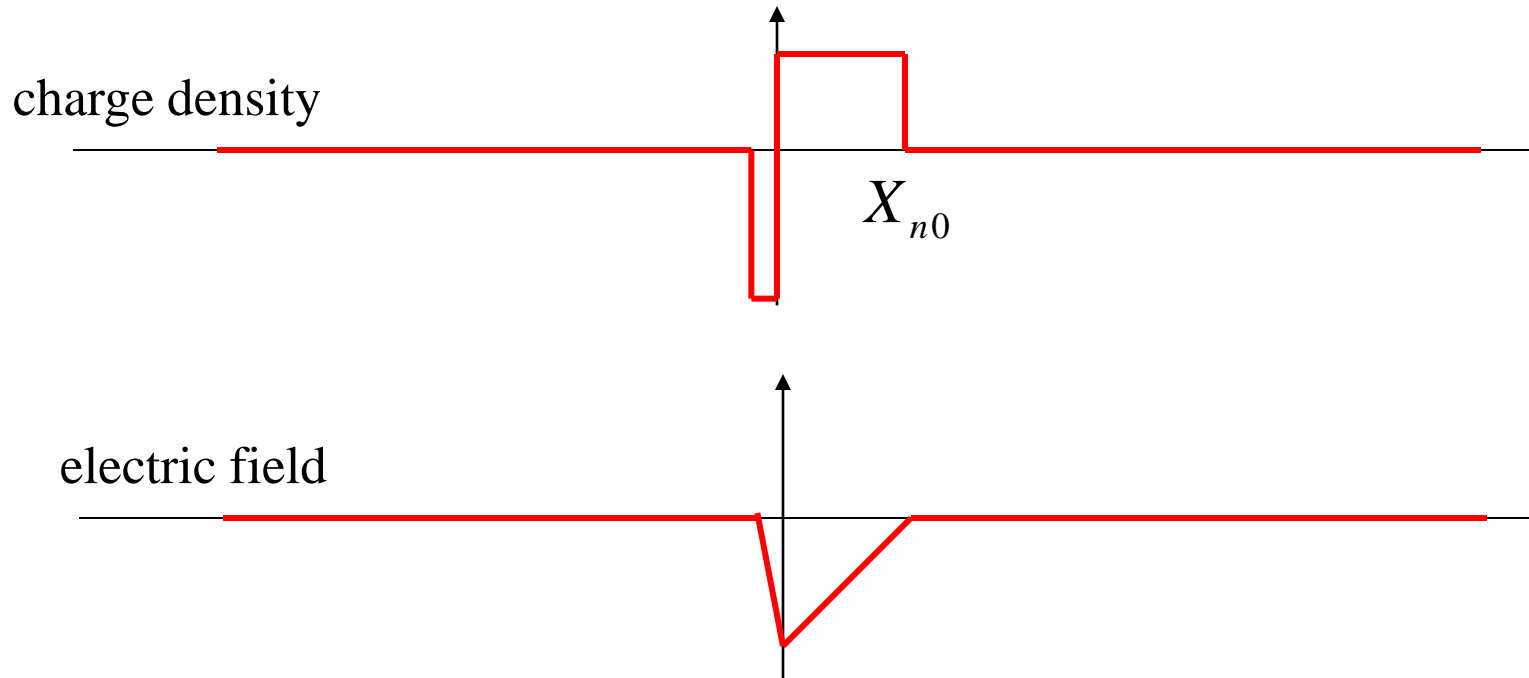

Schottky under bias

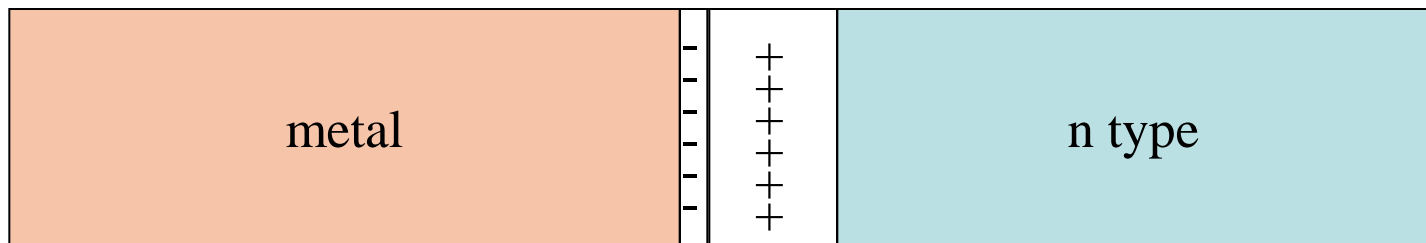
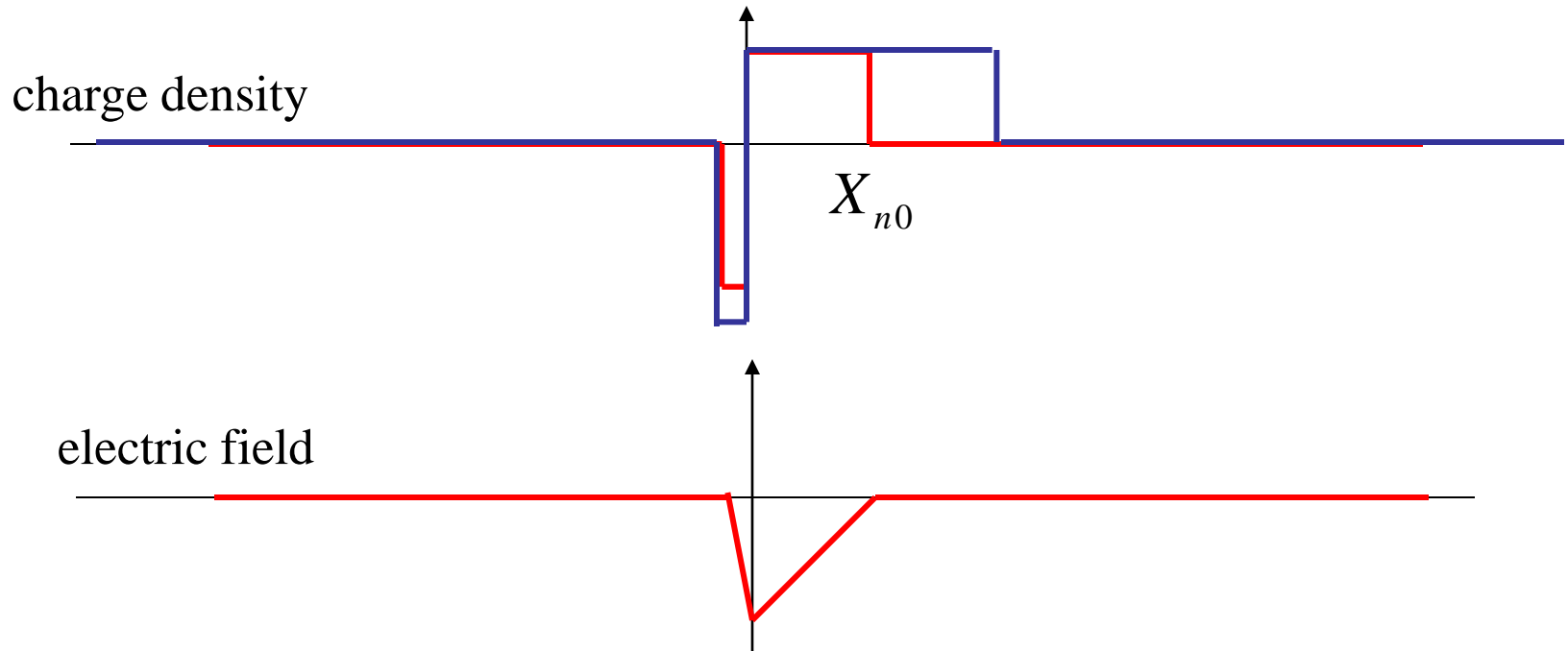

MESFET:

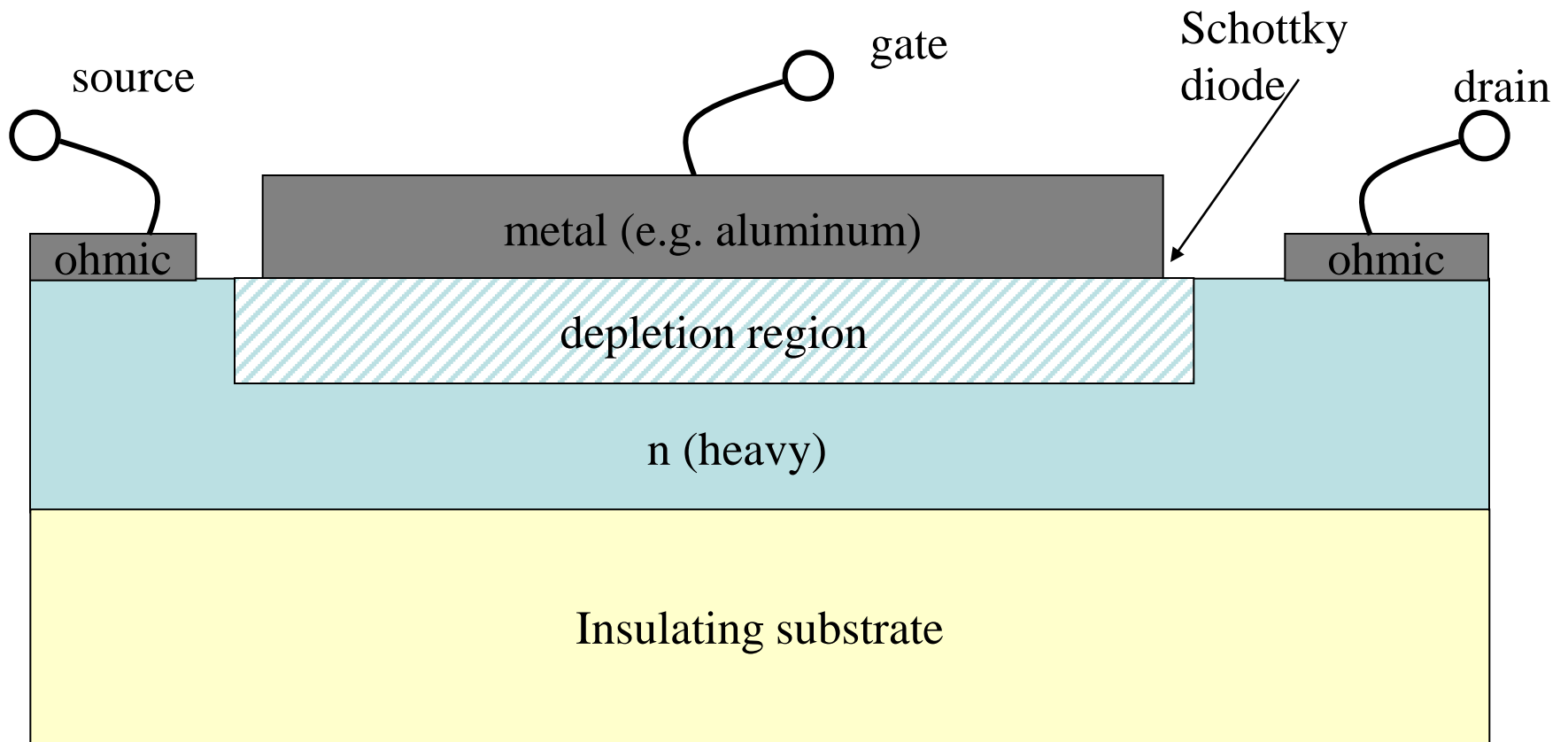

MESFET:

$$V_{\text{gate}} = -5 \text{ V}$$

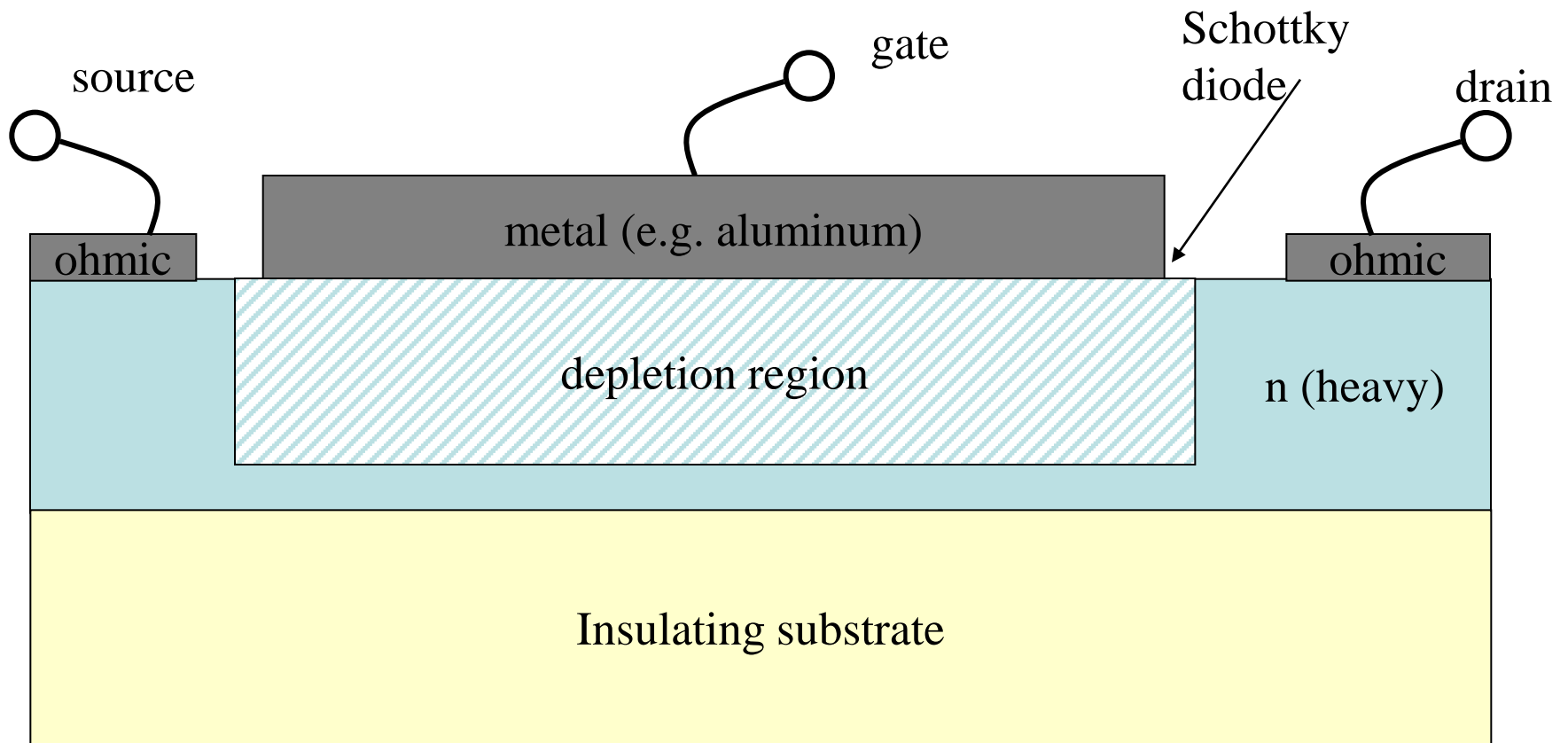

MESFET:

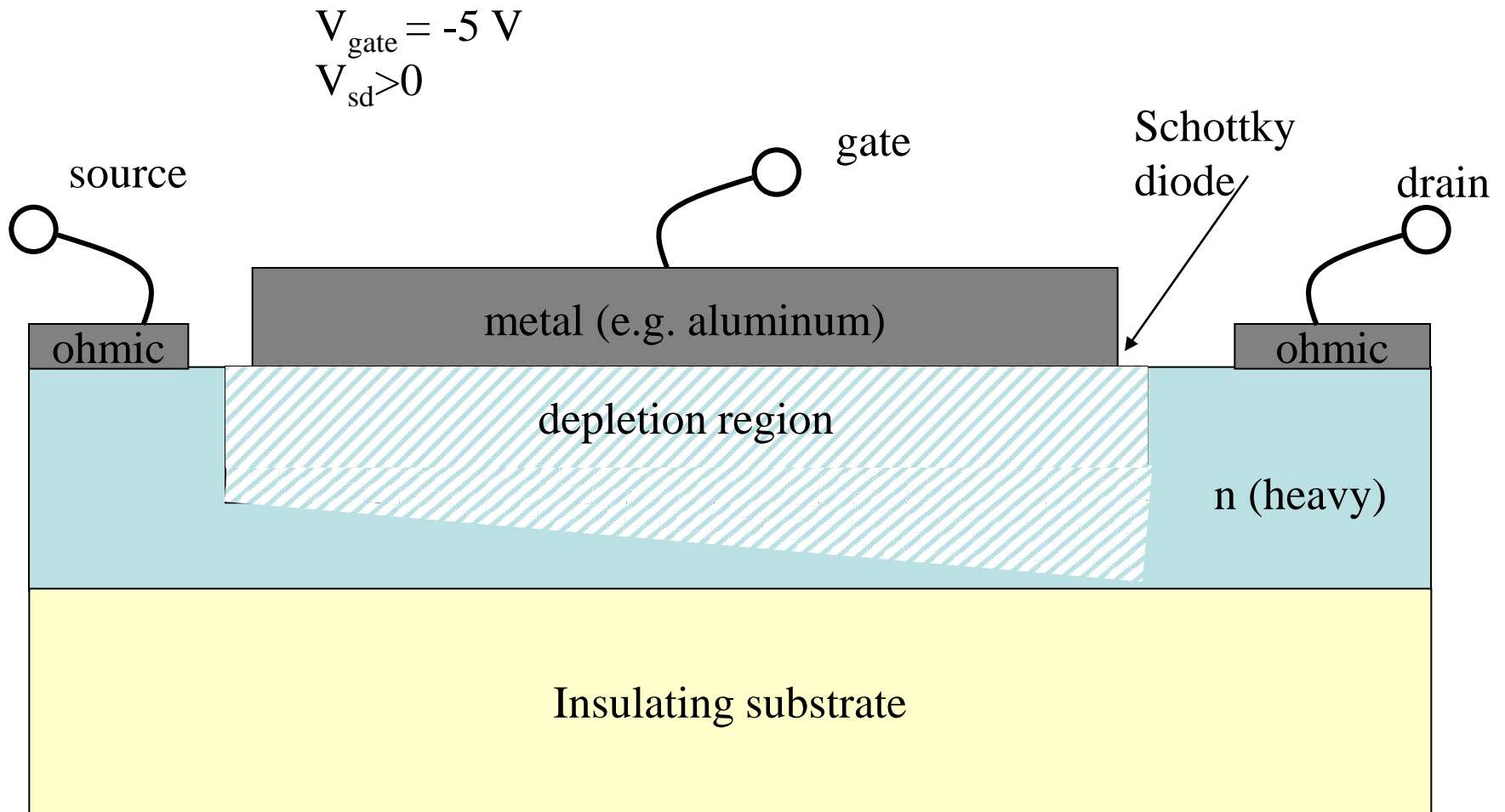

Transistor performance

- Want a lot of current: heavy doping
- Want high mobility for high f_T
- Heavy doping degrades mobility
- Solution: donors physically in different location than electrons: HEMT

“Mobility”

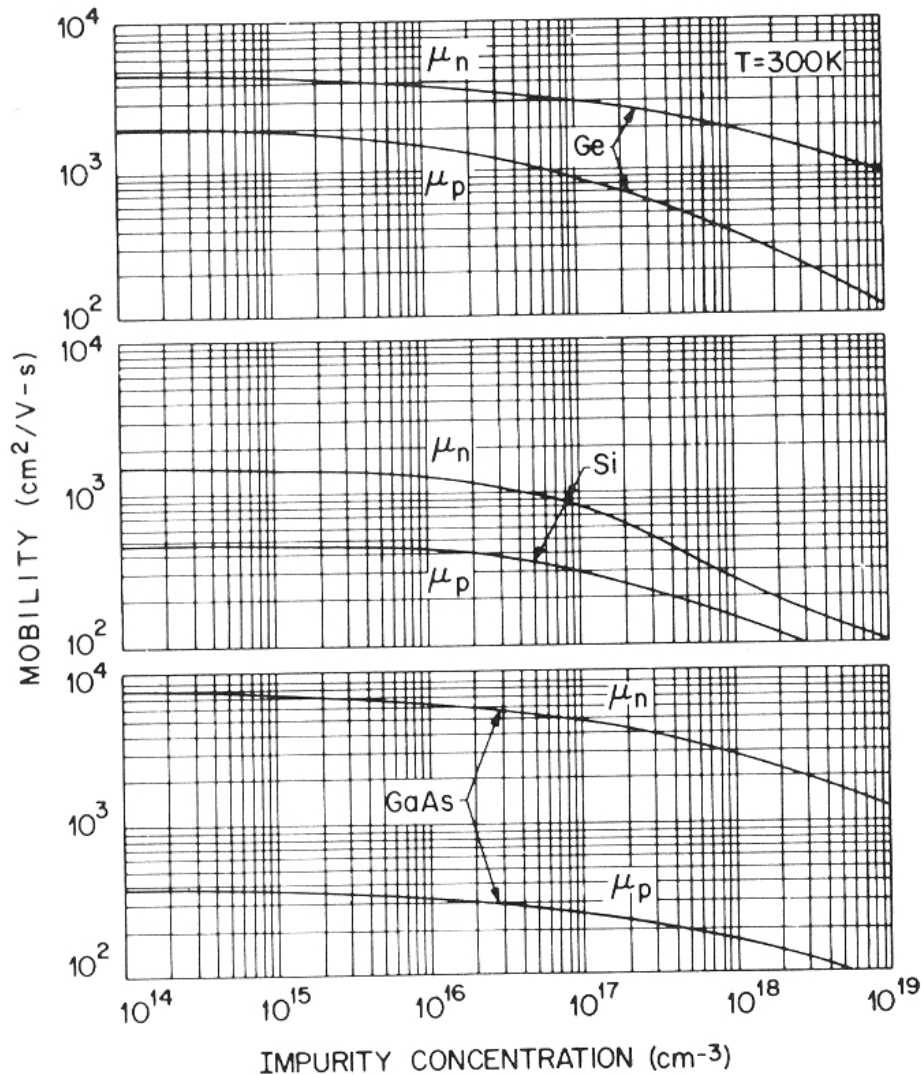

At low impurity concentration, electron-phonon scattering dominates.

At high impurity concentration, impurity scattering dominates.

$$\frac{1}{\tau_{total}} = \frac{1}{\tau_{electron-phonon}} + \frac{1}{\tau_{impurity}}$$

From Sze, Physics of Semiconductor Devices

HEMT:

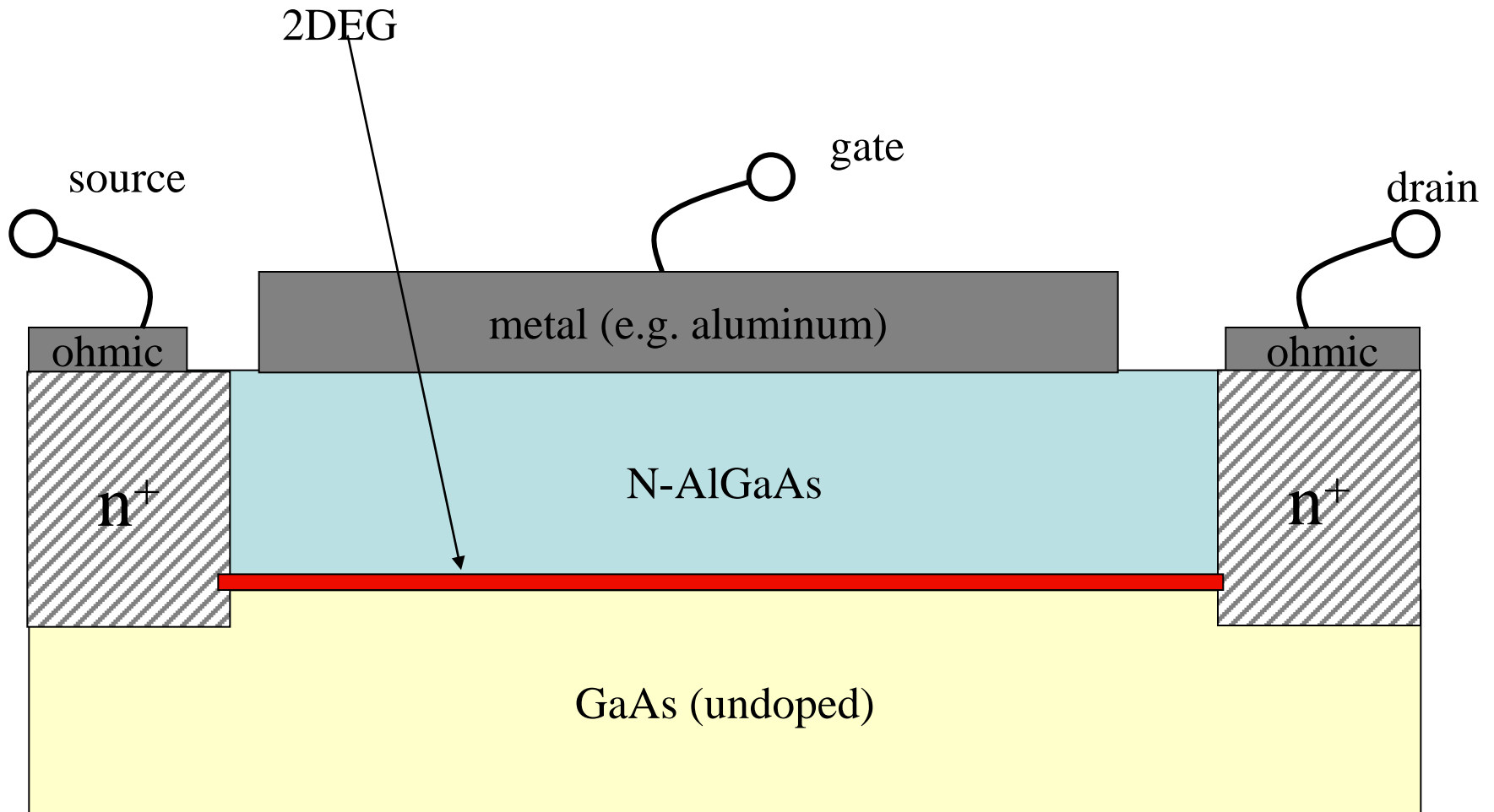

Band diagram

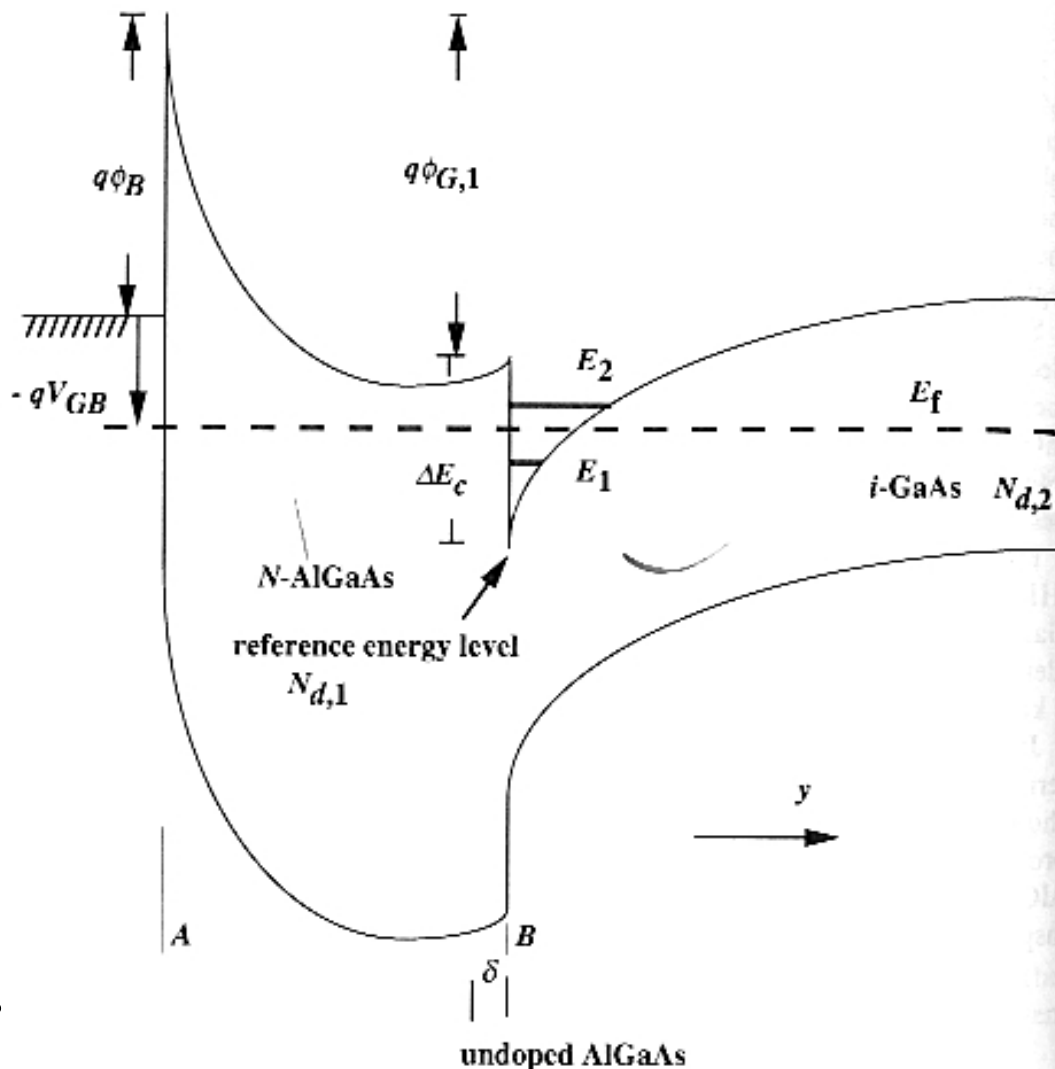

- Bias changes Fermi level
- hence density.
- Can “pinchoff”

From Liu.

MBE

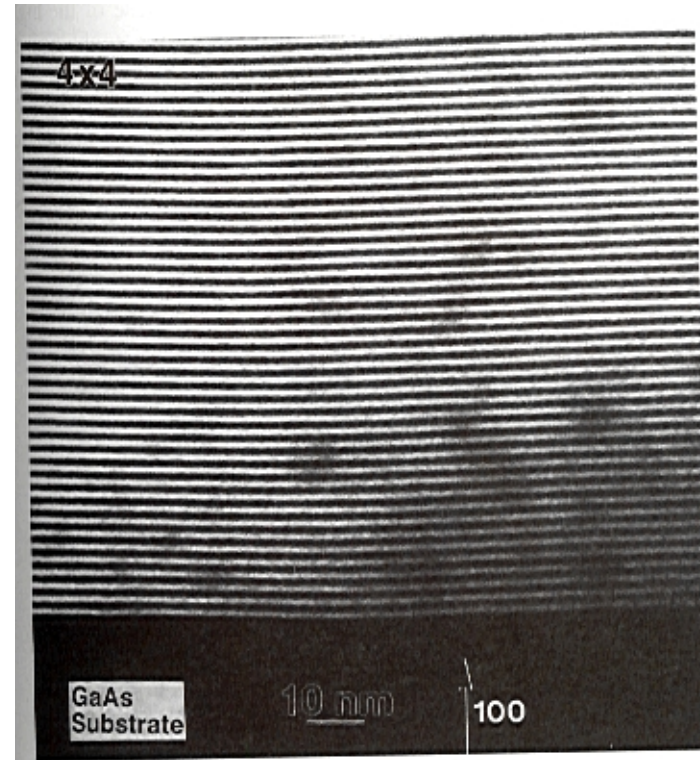
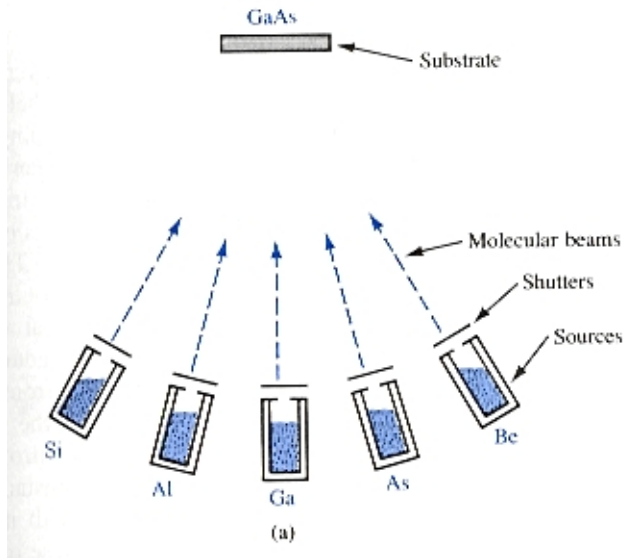

4 atom per layer!

(From Streetman, Solid State Electronic Devices)

MBE

epitaxial growth

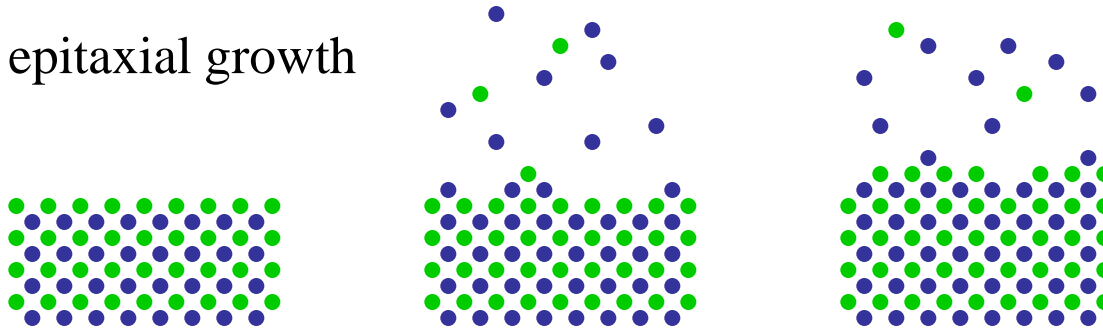

AlAs

GaAs

AlAs

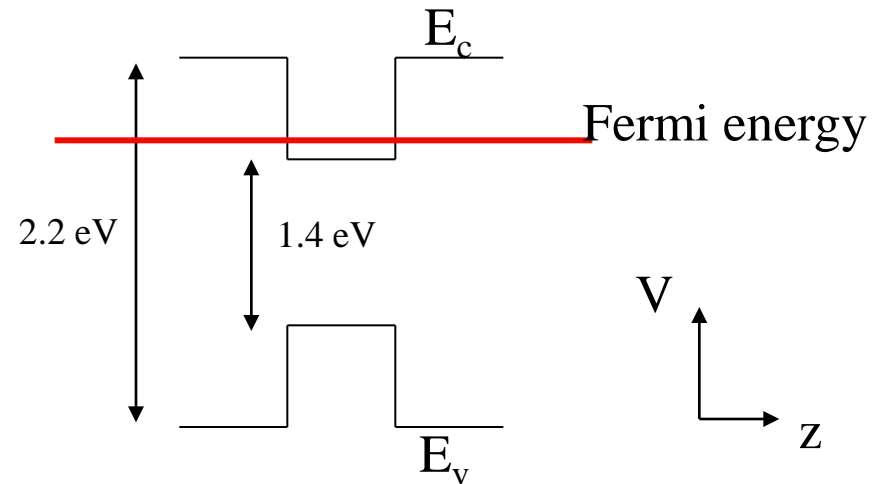
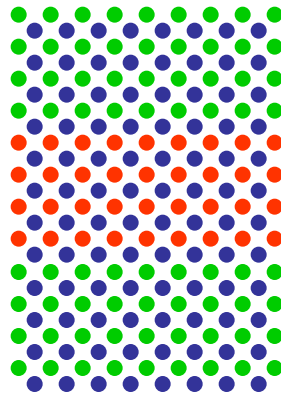

Also InP, InGaAs, InAlAs, InGaAsP

HEMT:

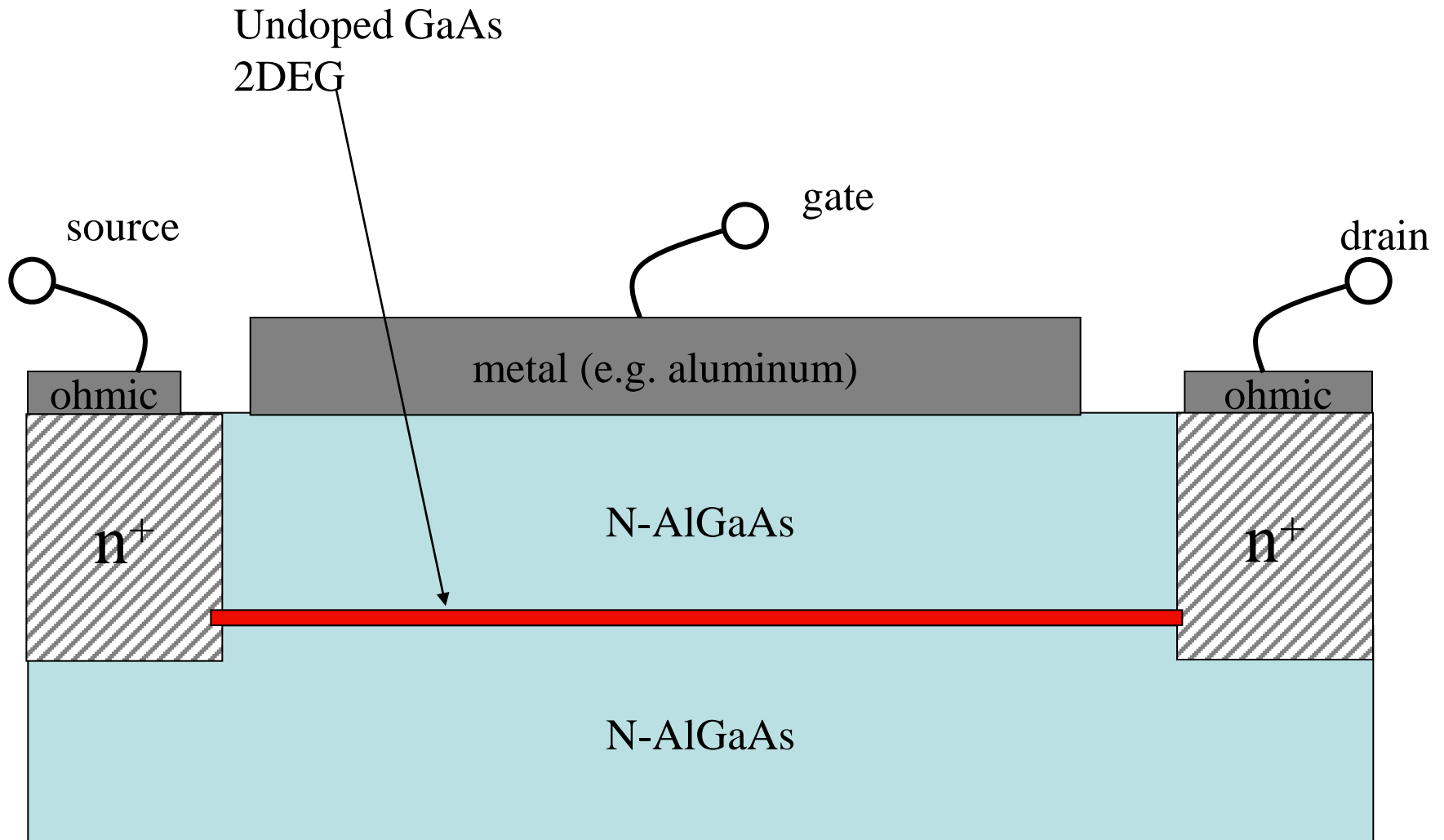

2DEG

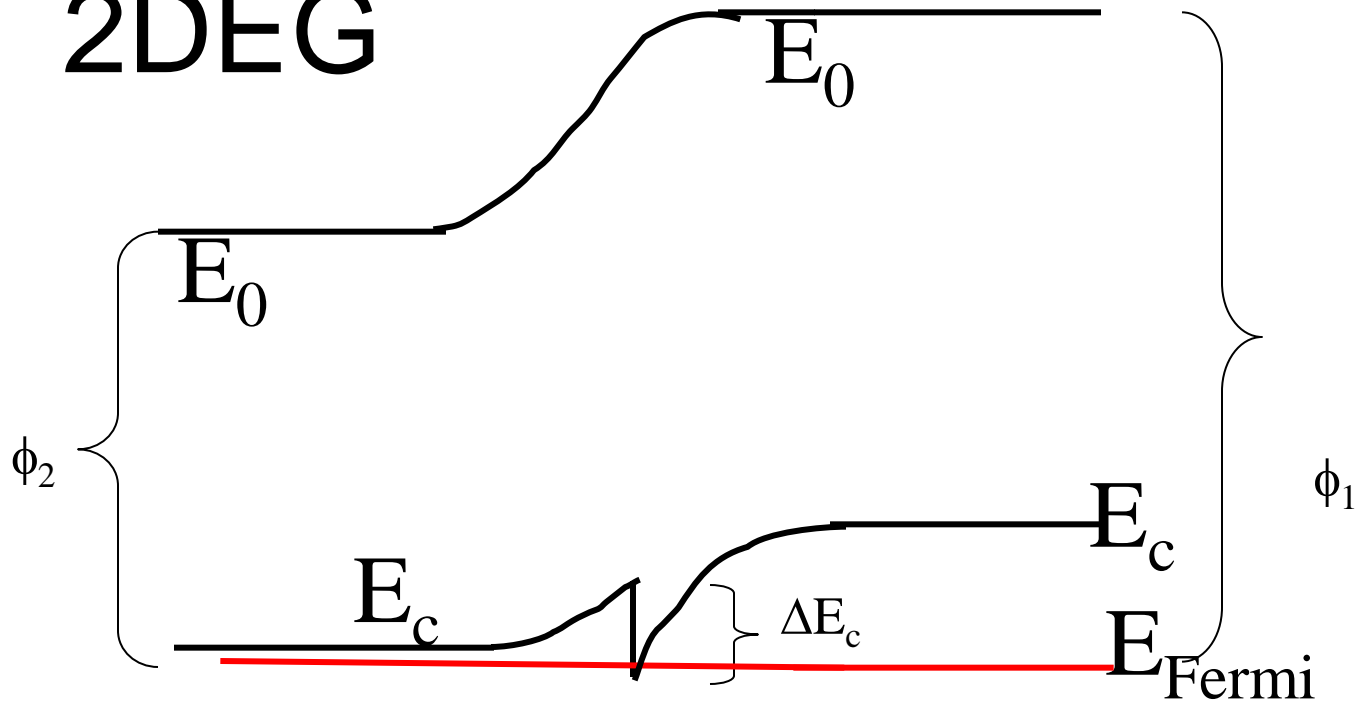

E_{Fermi}

GaAs

AlGaAs

E_v

E_v

ΔE_v

FET I-V curves

MESFET:

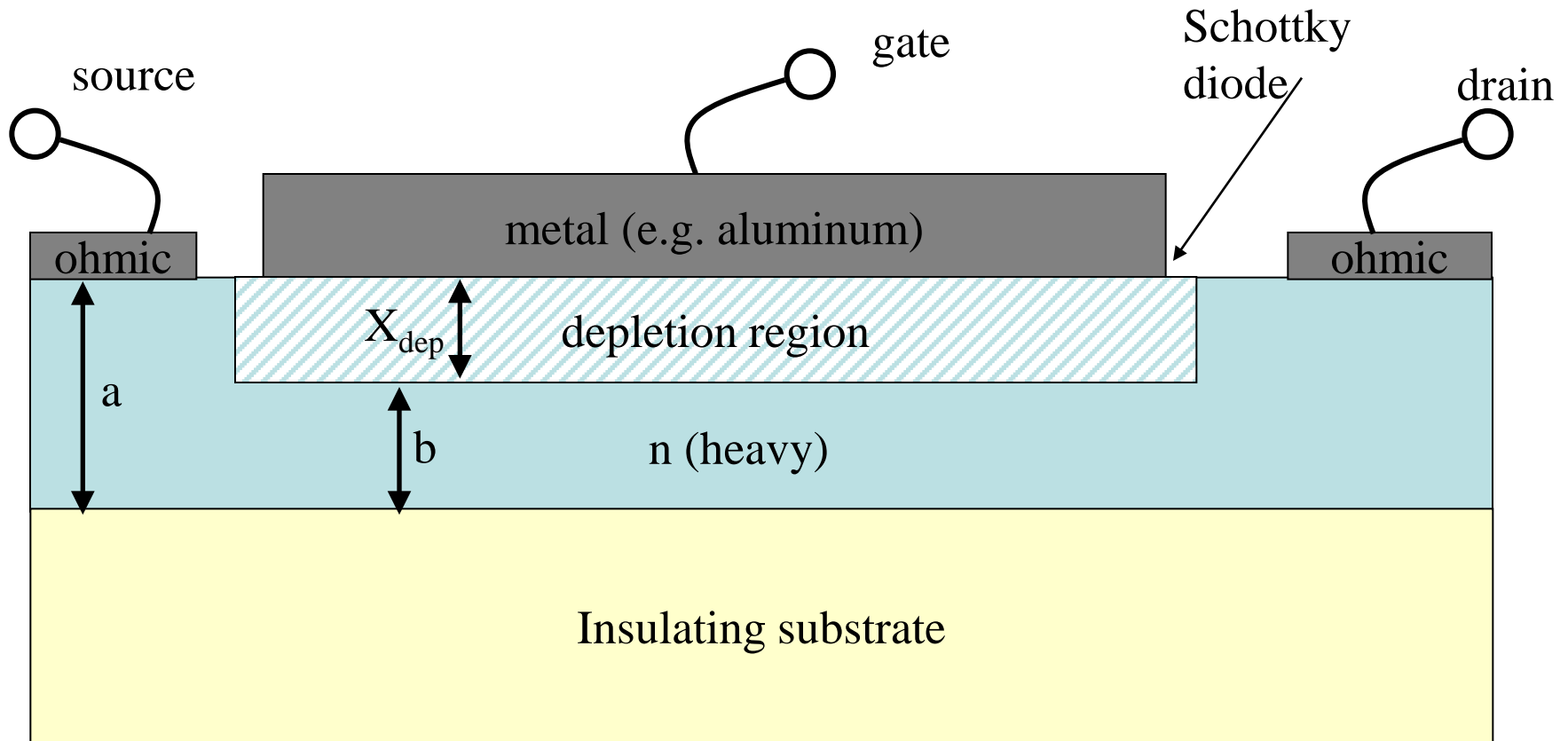

$$X_{dep} = \sqrt{\frac{2\epsilon}{eN_d} (\phi_{bi} - V_a)}$$

Goal:

Calculate I_{sd} vs. V_{sd}

Need to know shape of channel potential (not line)

MESFET:

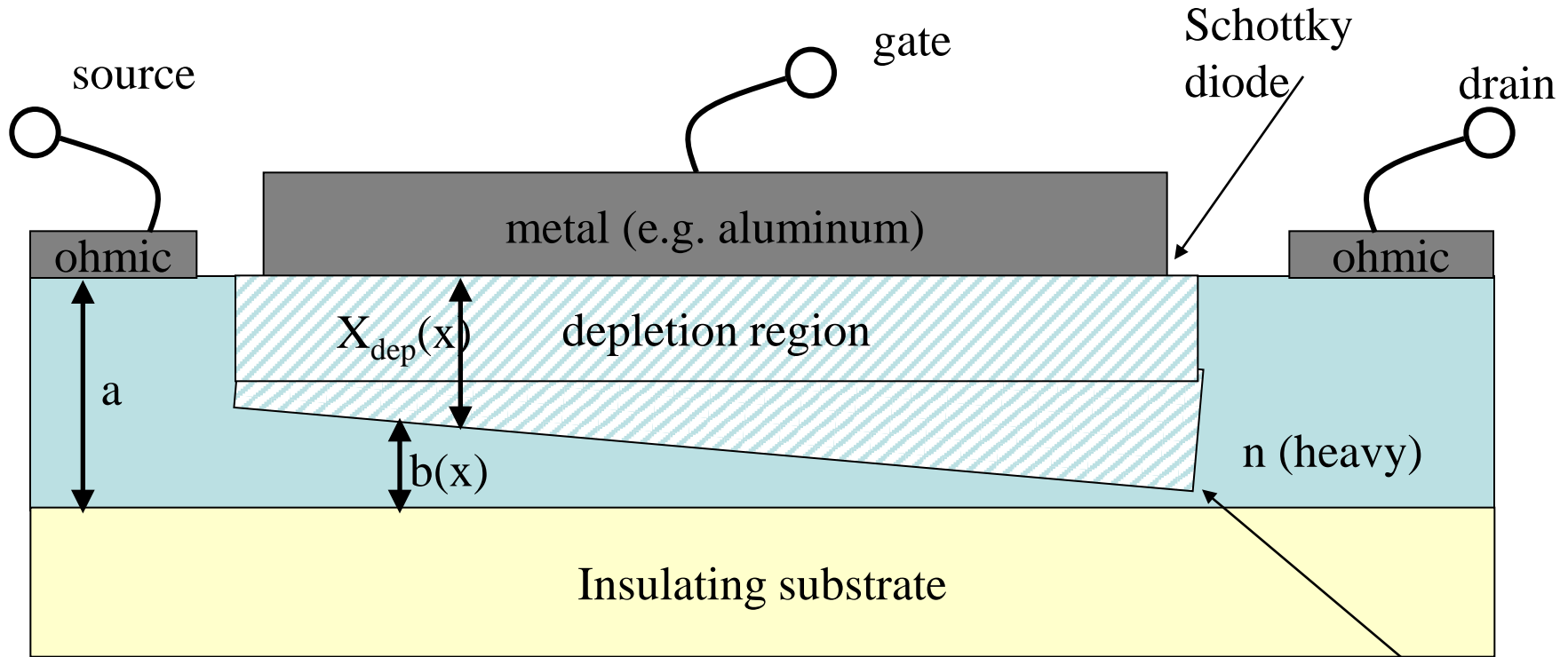

$$X_{dep} = \sqrt{\frac{2\epsilon}{eN_d} (\phi_{bi} - V_{GS} - V_{CS}(x))}$$

$$V_{CS}(x) = 0 @ x = 0$$

$$V_{CS}(x) = V_{SD} @ x = L$$

When they touch, define $V_{DS,sat}$

$$J = e \cdot \mu \cdot n \cdot E$$

$$I_D = J \cdot (area) = e \cdot \mu \cdot n(x) \cdot E(x) \cdot W \cdot b(x)$$

MESFET:

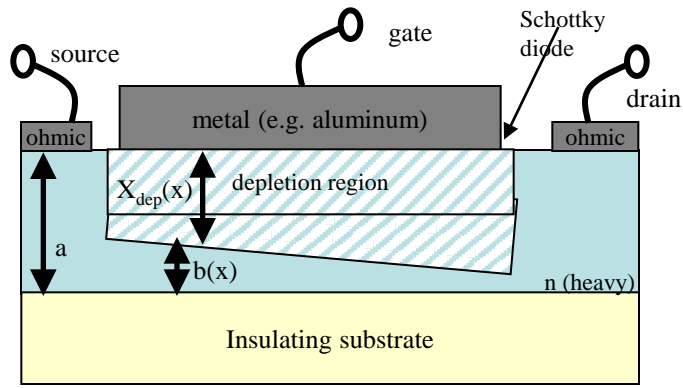

$$I_D = e \cdot \mu \cdot n(x) \cdot E(x) \cdot W \cdot b(x)$$

$$X_{dep} = \sqrt{\frac{2\varepsilon}{eN_d} \underbrace{(\phi_{bi} - V_{GS} - V_{CS}(x))}_{\phi_s(x)}}$$

$$E(x) = -\frac{\partial \phi_s(x)}{\partial x}$$

$$i_{ch} = e \cdot \mu \cdot N_d \cdot a \cdot W \cdot \left(1 - \sqrt{\frac{\phi_s(x)}{\phi_{00}}}\right) \cdot \left(-\frac{\partial \phi_s(x)}{\partial x}\right)$$

$$\phi_{00} \equiv \frac{eN_d}{2\varepsilon} a^2$$

We know $\phi(x)$ at both ends, but need to know full function to get $d\phi/dx$ for i_{ch} .

$$\frac{\partial i_{ch}}{\partial x} = 0$$

(Current is conserved.)

$$\int_x^L i_{ch} dx' = \int_x^L e \cdot \mu \cdot N_d \cdot a \cdot W \cdot \left(1 - \sqrt{\frac{\phi_s(x')}{\phi_{00}}}\right) \cdot \left(-\frac{\partial \phi_s(x')}{\partial x'}\right) dx'$$

MESFET:

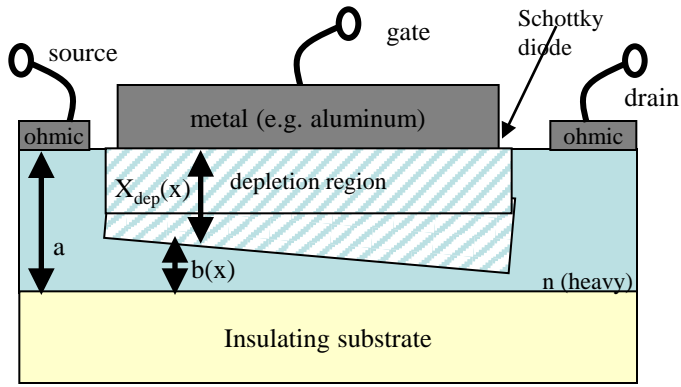

$$\phi_s(x) \equiv \phi_{bi} - V_{GS} - V_{CS}(x)$$

$$V_{CS}(x) = 0 @ x = 0$$

$$V_{CS}(x) = V_{SD} @ x = L$$

$$\int_x^L i_{ch} dx' = \int_x^L e \cdot \mu \cdot N_d \cdot a \cdot W \cdot \left(1 - \sqrt{\frac{\phi_s(x')}{\phi_{00}}}\right) \cdot \left(-\frac{\partial \phi_s(x')}{\partial x'}\right) dx'$$

$$LHS = I_D(L - x)$$

$$RHS = \int_{\phi_s(x)}^{\phi_s(L)} e \cdot \mu \cdot N_d \cdot a \cdot W \cdot \left(1 - \sqrt{\frac{\phi_s(x')}{\phi_{00}}}\right) \cdot \left(-\frac{\partial \phi_s(x')}{\partial x'}\right)$$

$$= e \cdot \mu \cdot N_d \cdot a \cdot W \cdot \left[\phi_s(L) - \phi_s(x) - \frac{2}{3} \left(\frac{\phi_s(0)}{\phi_{00}}\right)^{3/2} + \frac{2}{3} \left(\frac{\phi_s(x)}{\phi_{00}}\right)^{3/2} \right]$$

$$\Rightarrow I_D = \frac{1}{L - x} e \cdot \mu \cdot N_d \cdot a \cdot W \cdot \left[\phi_s(L) - \phi_s(x) - \frac{2}{3} \left(\frac{\phi_s(0)}{\phi_{00}}\right)^{3/2} + \frac{2}{3} \left(\frac{\phi_s(x)}{\phi_{00}}\right)^{3/2} \right]$$

MESFET:

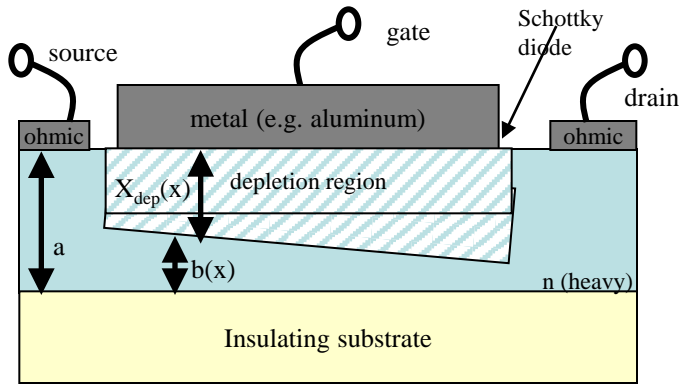

$$\phi_s(x) \equiv \phi_{bi} - V_{GS} - V_{CS}(x)$$

If

$$V_{CS}(x) > V_{SD,Sat}$$

then

$$\phi_s(x) \equiv \phi_{bi} - V_{GS} - V_{SD,sat}$$

$$V_{CS}(x) = 0 @ x = 0$$

$$V_{CS}(x) = V_{SD} @ x = L$$

$$I_D = \frac{1}{L-x} e \cdot \mu \cdot N_d \cdot a \cdot W \cdot \left[\phi_s(L) - \phi_s(x) - \frac{2}{3} \left(\frac{\phi_s(0)}{\phi_{00}} \right)^{3/2} + \frac{2}{3} \left(\frac{\phi_s(x)}{\phi_{00}} \right)^{3/2} \right]$$

For $x = 0$:

$$I_D = \frac{1}{L} e \cdot \mu \cdot N_d \cdot a \cdot W \cdot \left[\phi_s(L) - \phi_s(0) - \frac{2}{3} \left(\frac{\phi_s(0)}{\phi_{00}} \right)^{3/2} + \frac{2}{3} \left(\frac{\phi_s(0)}{\phi_{00}} \right)^{3/2} \right]$$

This is desired I_D vs V_{sd} .

Called gradual channel approximation (assumes $a \ll L$).

Potential profile:

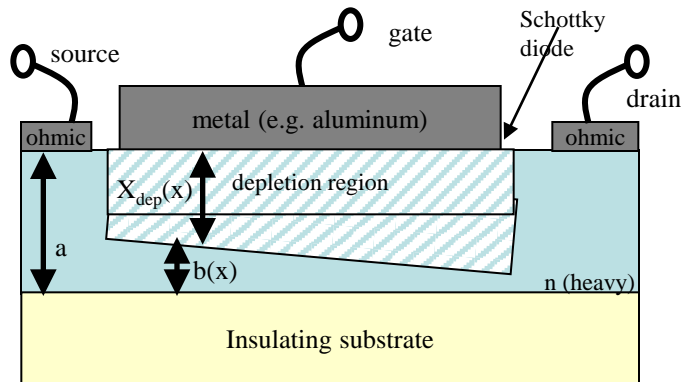

$$\phi_s(x) \equiv \phi_{bi} - V_{GS} - V_{CS}(x)$$

If

$$V_{CS}(x) > V_{SD,Sat}$$

then

$$\phi_s(x) \equiv \phi_{bi} - V_{GS} - V_{SD,sat}$$

$$V_{CS}(x) = 0 @ x = 0$$

$$V_{CS}(x) = V_{SD} @ x = L$$

$$I_D = \frac{1}{L-x} e \cdot \mu \cdot N_d \cdot a \cdot W \cdot \left[\phi_s(L) - \phi_s(x) - \frac{2}{3} \left(\frac{\phi_s(0)}{\phi_{00}} \right)^{3/2} + \frac{2}{3} \left(\frac{\phi_s(x)}{\phi_{00}} \right)^{3/2} \right]$$

For $x = 0$:

$$I_D = \frac{1}{L} e \cdot \mu \cdot N_d \cdot a \cdot W \cdot \left[\phi_s(L) - \phi_s(0) - \frac{2}{3} \left(\frac{\phi_s(0)}{\phi_{00}} \right)^{3/2} + \frac{2}{3} \left(\frac{\phi_s(0)}{\phi_{00}} \right)^{3/2} \right]$$

So:

$$\phi_s(x) - \phi_s(0) - \frac{2}{3} \left(\frac{\phi_s(x)}{\phi_{00}} \right)^{3/2} + \frac{2}{3} \left(\frac{\phi_s(0)}{\phi_{00}} \right)^{3/2} = \frac{x}{L} \left(\phi_s(L) - \phi_s(0) - \frac{2}{3} \left(\frac{\phi_s(L)}{\phi_{00}} \right)^{3/2} + \frac{2}{3} \left(\frac{\phi_s(0)}{\phi_{00}} \right)^{3/2} \right)$$

This is a transcendental equation for $\phi_s(x)$

Velocity saturation

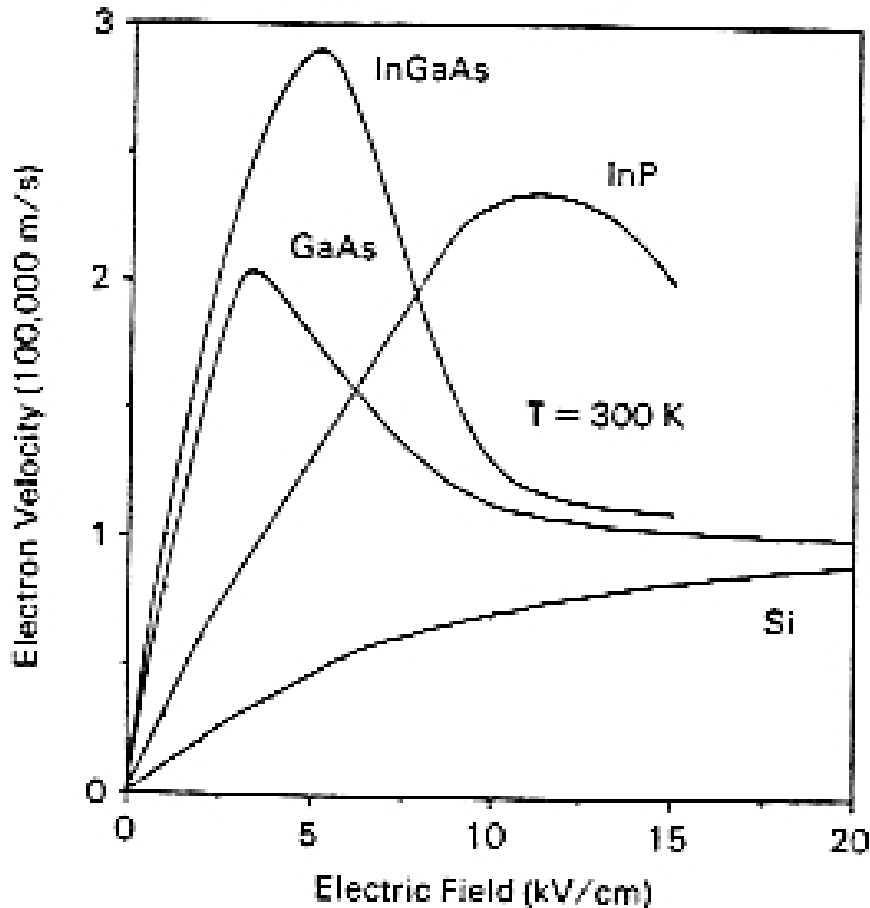

$$v = \mu \cdot E$$

$$\rightarrow v_{sat}$$

From Shur, Physics of Semiconductor Devices

Velocity saturation:

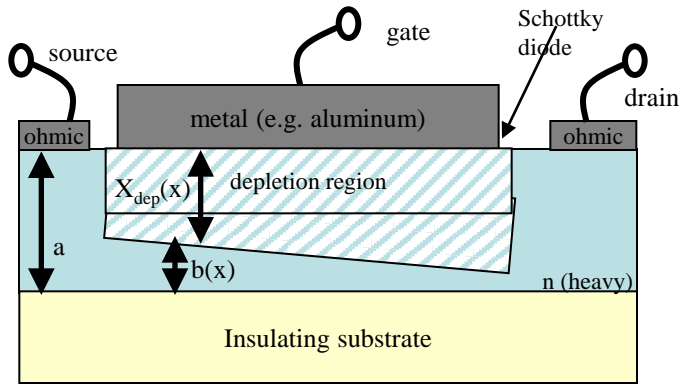

$$J = e \cdot \mu \cdot n \cdot E$$

Not true for short channels (discuss on board).

$$J = e \cdot n \cdot v_{sat}$$

Independent of E.

Need to recalculate IV curve. Model as linear and saturated velocity regions.
Also, model as two-region velocity-field curve.
I-V curve is similar to long-channel FET qualitatively.