

Lecture 6: HBT parasitics

f_T, f_{max}

Common-Emitter AC equivalent circuit:

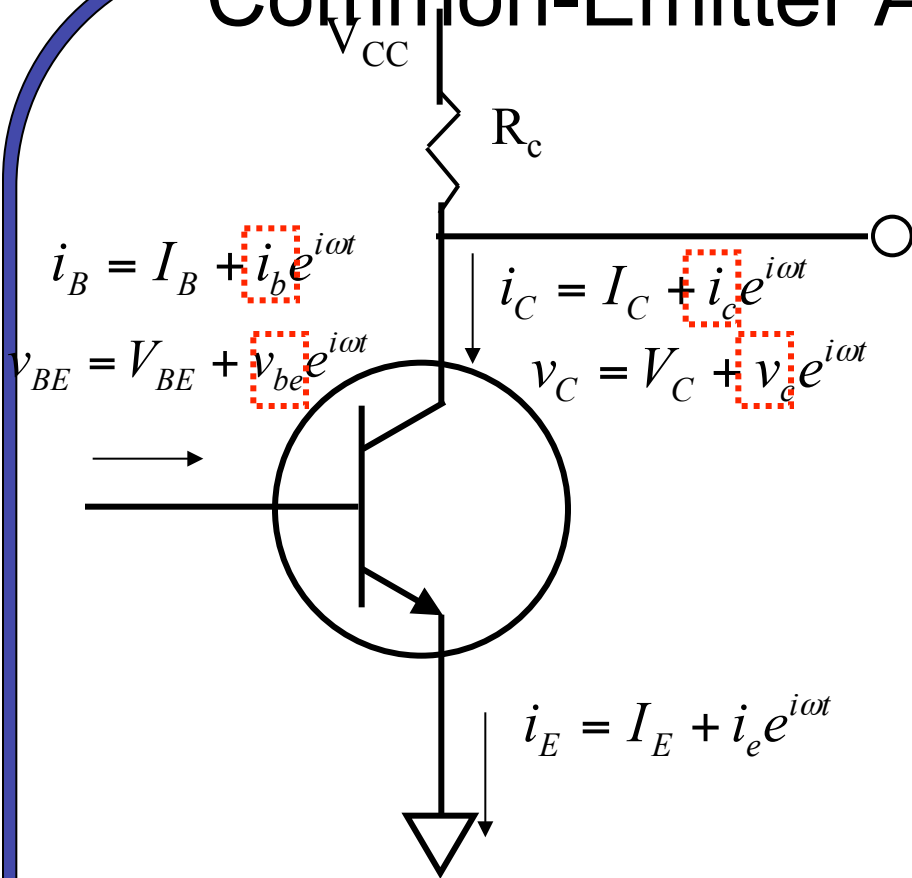

Hybrid π model:
Red is new for ac:

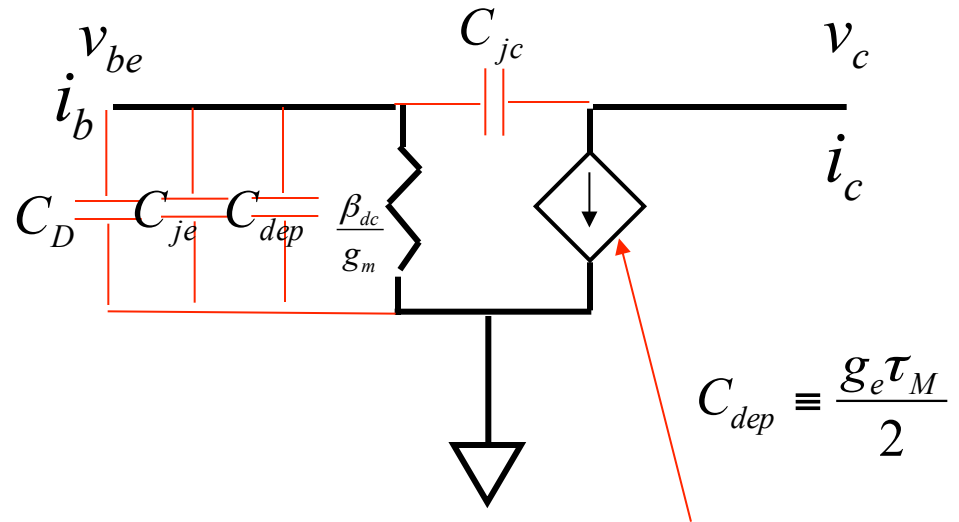

$$\left(1 - \frac{X_B^2}{2L_n^2}\right) g_e \left[1 - i \frac{\omega}{3\omega_0}\right] e^{\omega\tau_M/2} v_{be}$$

- Circuit model good only for low frequencies
- At high frequencies computer must be used!

Hybrid π model:

simplified:

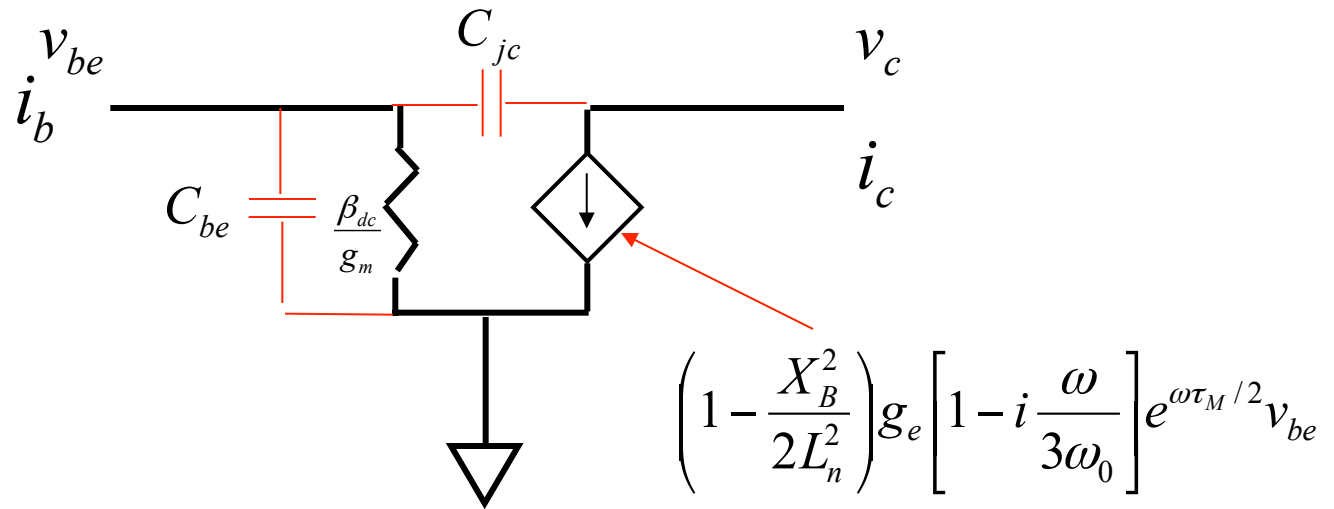

S-matrix

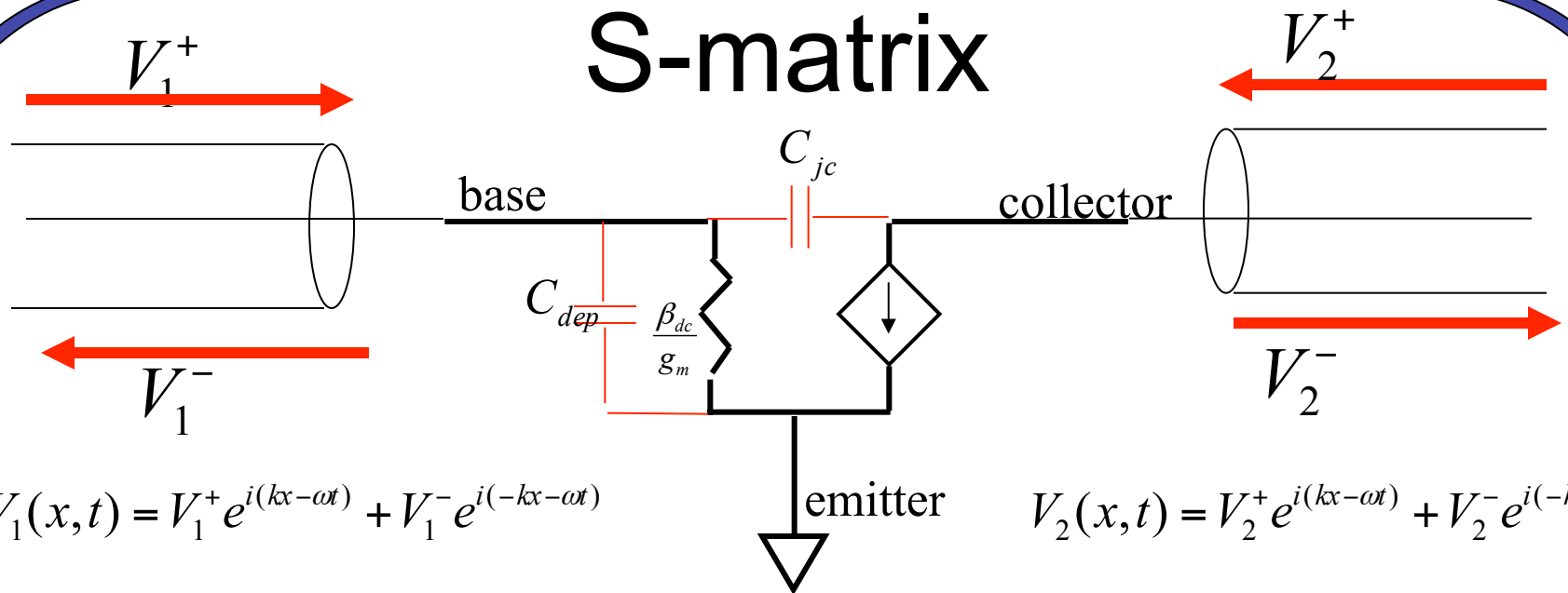

$$\begin{pmatrix} V_1^- \\ V_2^- \end{pmatrix} = \begin{pmatrix} S_{11} & S_{12} \\ S_{21} & S_{22} \end{pmatrix} \begin{pmatrix} V_1^+ \\ V_2^+ \end{pmatrix}$$

$$V_1^- = S_{11} V_1^+ + S_{12} V_2^+$$

$$V_2^- = S_{21} V_1^+ + S_{22} V_2^+$$

S-parameters

TOSHIBA

2SA1245

This is what you see on data sheets.
Related to input impedance, output impedance
and gain vs. frequency.
=> Need to discuss ac performance.

S_{11e}
 $V_{CE} = -5V$
 $I_C = -10mA$
 $T_a = 25^\circ C$
(UNIT : Ω)

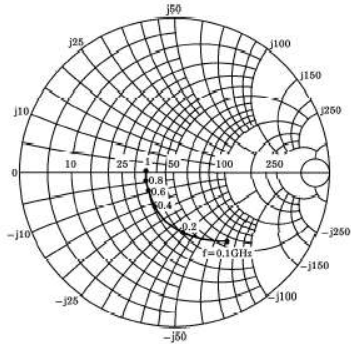

S_{12e}
 $V_{CE} = -5V$
 $I_C = -10mA$
 $T_a = 25^\circ C$

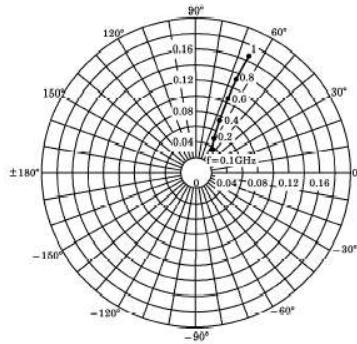

S_{21e}
 $V_{CE} = -5V$
 $I_C = -10mA$
 $T_a = 25^\circ C$

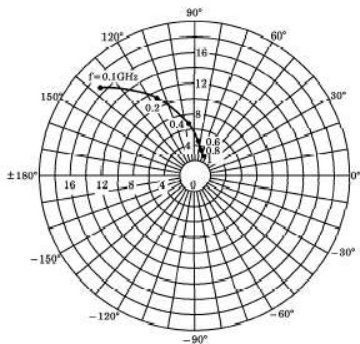

S_{22e}
 $V_{CE} = -5V$
 $I_C = -10mA$
 $T_a = 25^\circ C$
(UNIT : Ω)

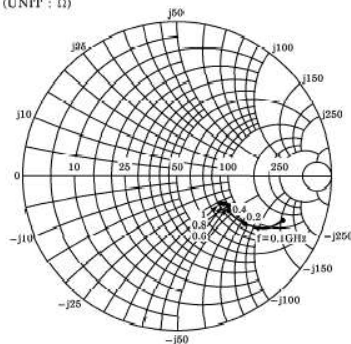

Summary of parameters

- Impedance matrix ($V=IR \rightarrow V=IZ$)
- Admittance matrix ($I=YV$)
- h-matrix (combination)
- ABCD matrix (combination)
- S-matrix (microwave reflections and transmissions)

“If you know one, then you know them all...”

See Liu, page 249 for conversions.

Measurement techniques

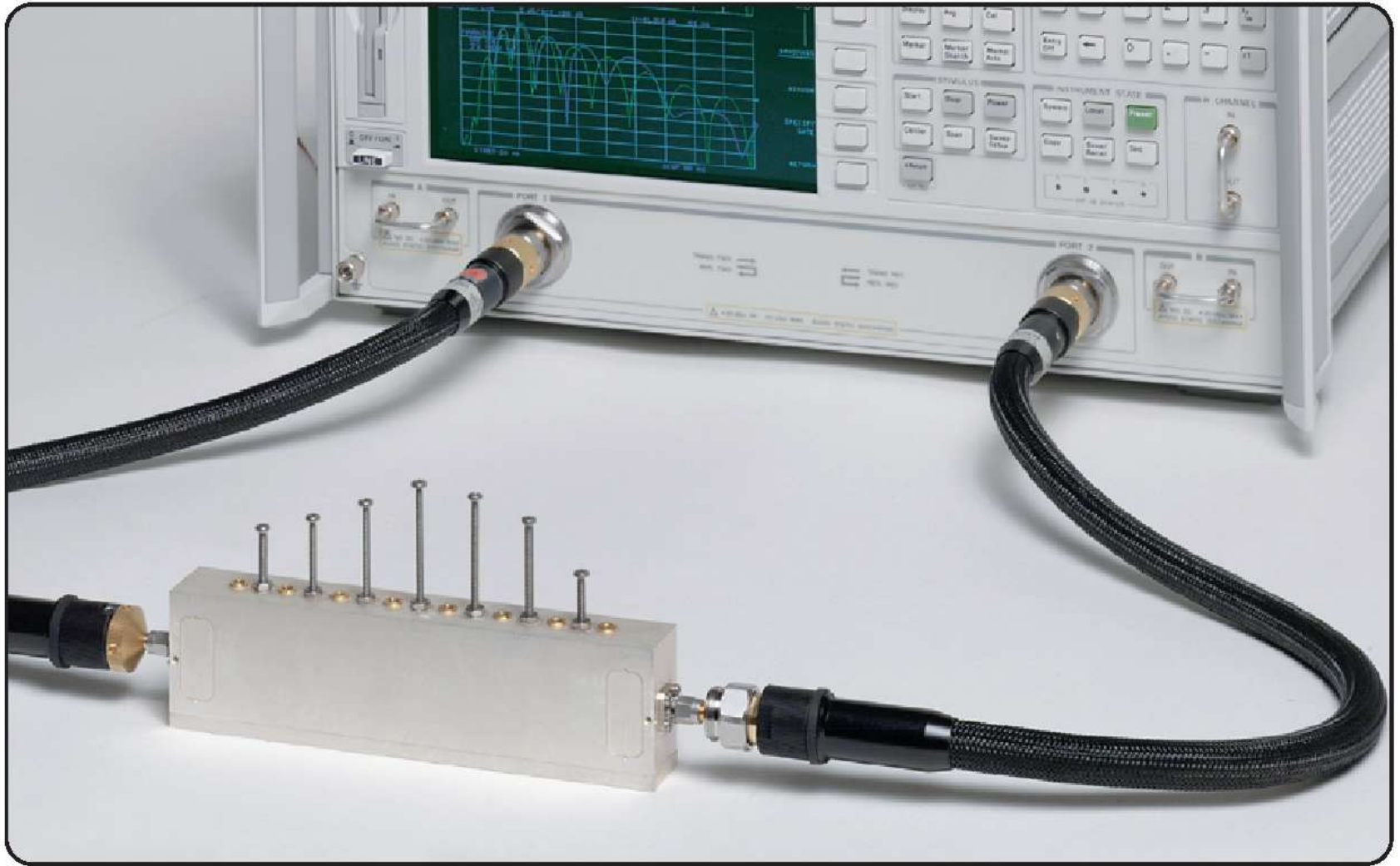

Measurement techniques

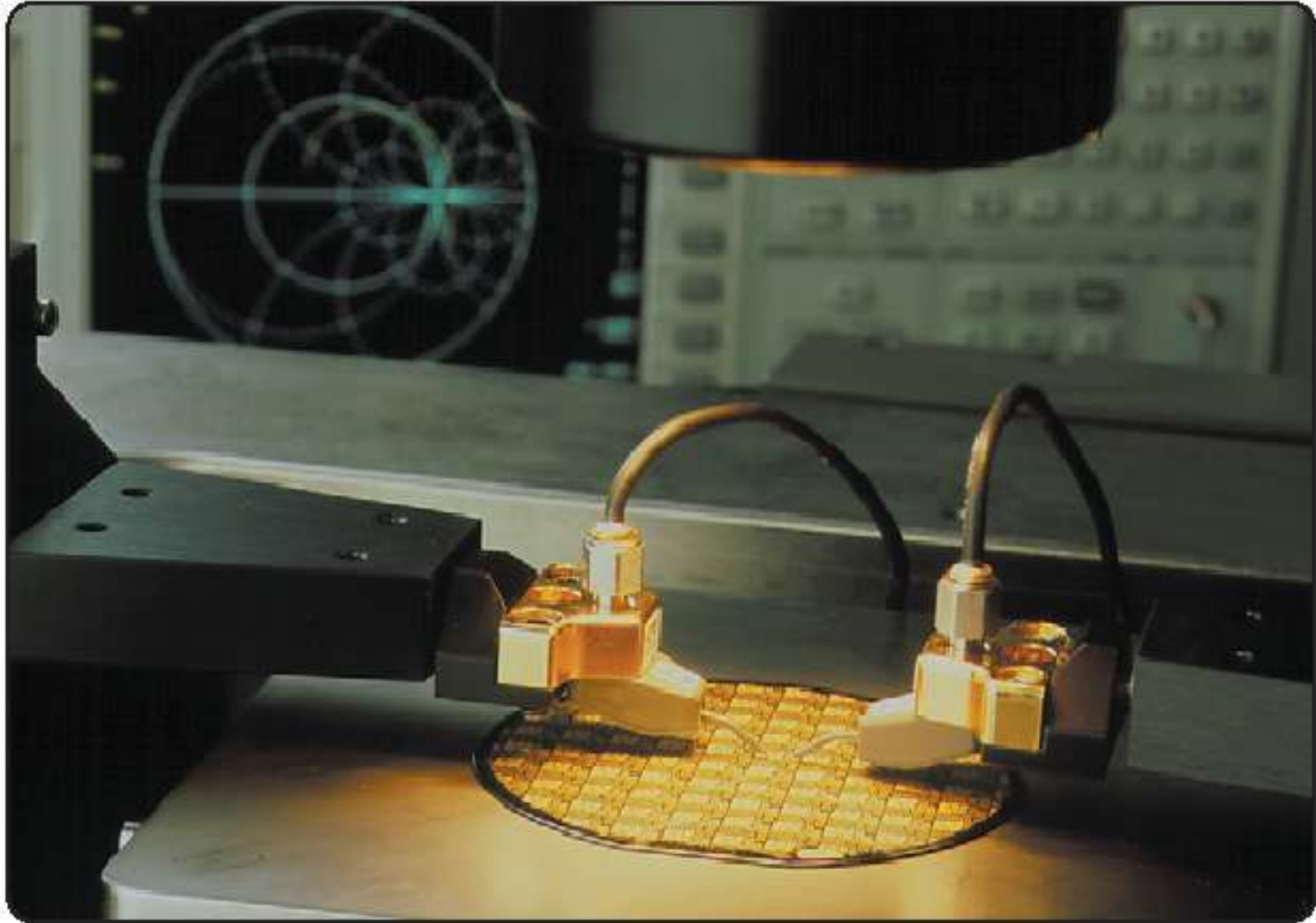

Cost (*rough* estimates)

- 10 GHz: \$50,000
- 20 GHz: \$70,000
- 40 GHz: \$90,000
- 110 GHz: \$250,000
- > 110 GHz: very expensive

For cost and difficulty reasons, parameters of transistor not always measure all the way up to f_T , but extrapolated.

These are only estimates. Contact vendor for actual prices.

Example

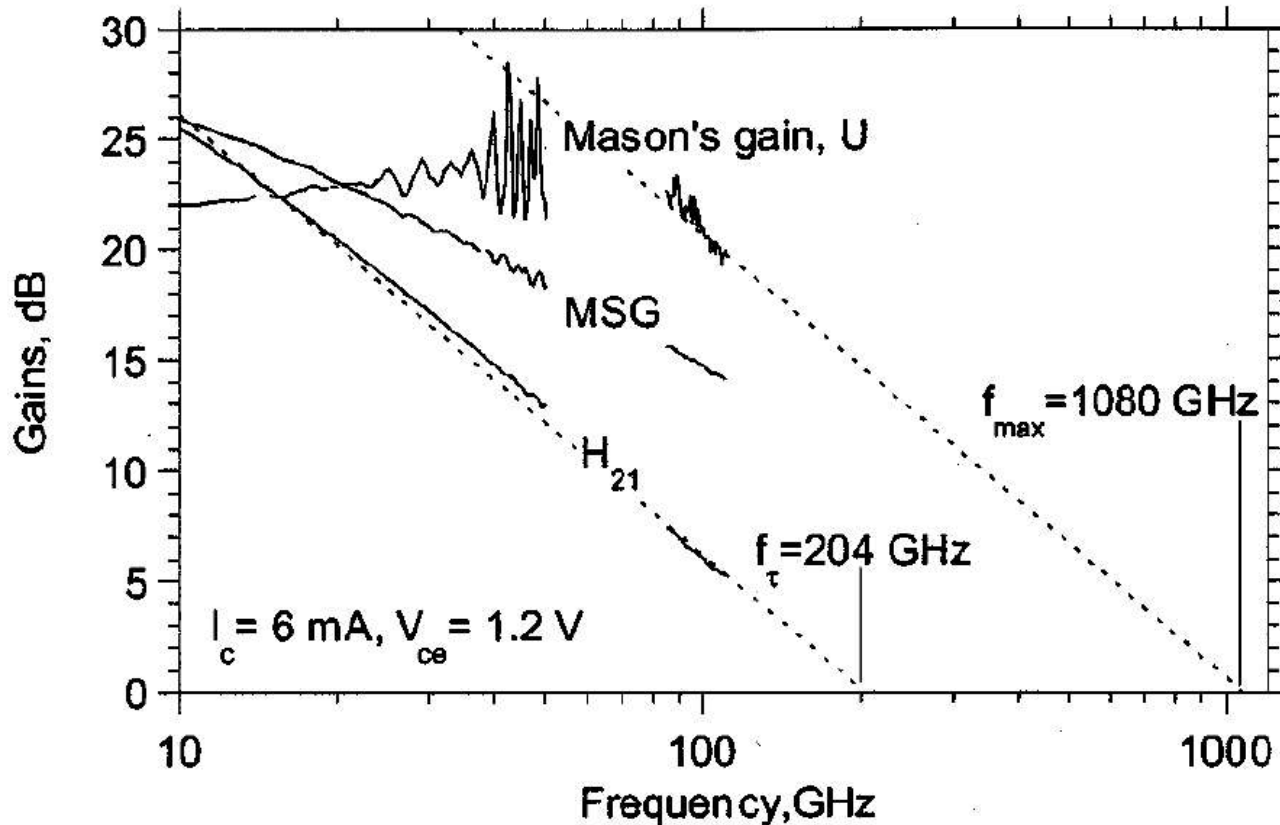
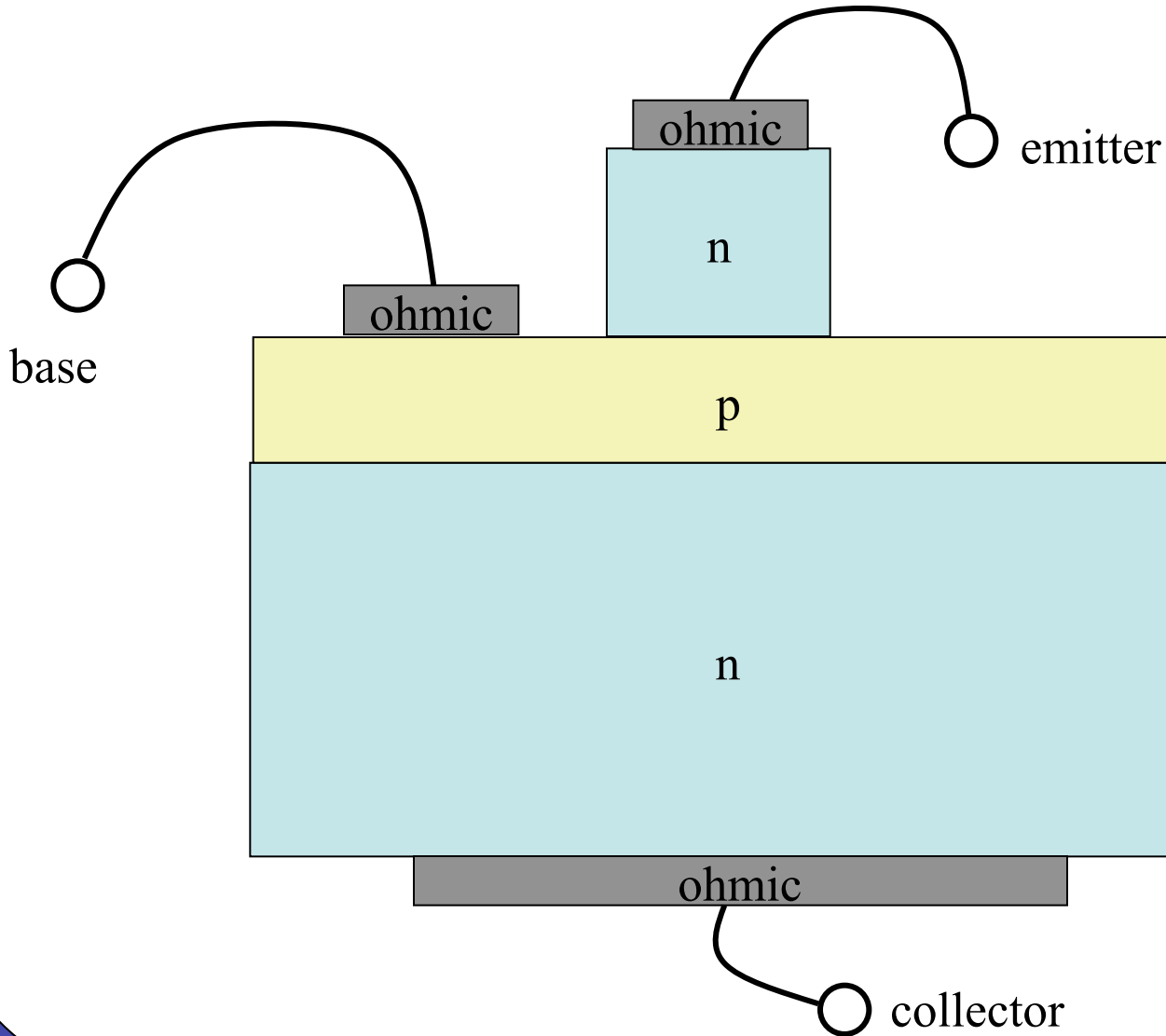

Fig. 14. Gains of a $0.4 \mu\text{m} \times 6 \mu\text{m}$ emitter and $0.7 \mu\text{m} \times 10 \mu\text{m}$ collector HBT fabricated using electron-beam lithography. Theoretical -20 dB/decade (H_{21} , U) gain slopes are indicated. The device exhibits an *extrapolated* 1.08 THz f_{\max} .

From Rodwell, et al, TRANSACTIONS ON ELECTRON DEVICES 48 (11): 2606-2624 IEEE NOV 2001

Parasitics:



Parasitics:

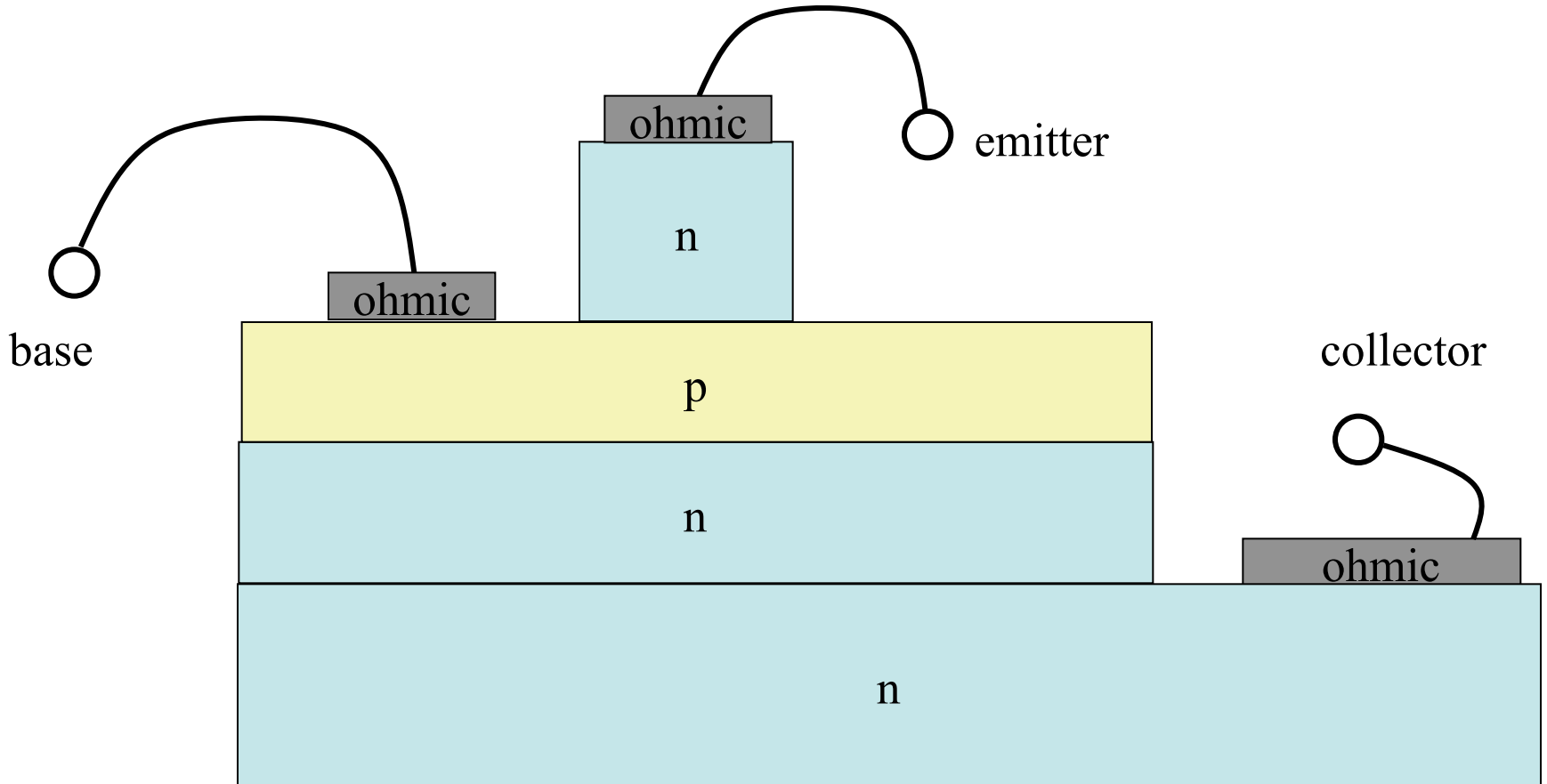

Ohmic contact

Specific contact resistance typically 10^{-6} ohm-micron²
(Discuss on board.)

$$R_{EE} = \frac{\rho_{\sigma E}}{A_E} = \frac{\rho_{\sigma E}}{L_E W_E}$$

For a distributed contact, things are a little more complicated.
(Draw distributed RC network on board, discuss.)

A solution is:

$$R_{BB} = \frac{\sqrt{R_{SHB} \rho_{\sigma B}}}{L_E} \coth \left(W_B \sqrt{\frac{R_{SHB}}{\rho_{\sigma B}}} \right)$$

R_{SHB} is R per square (discuss)

Emitter “epi” resistance:

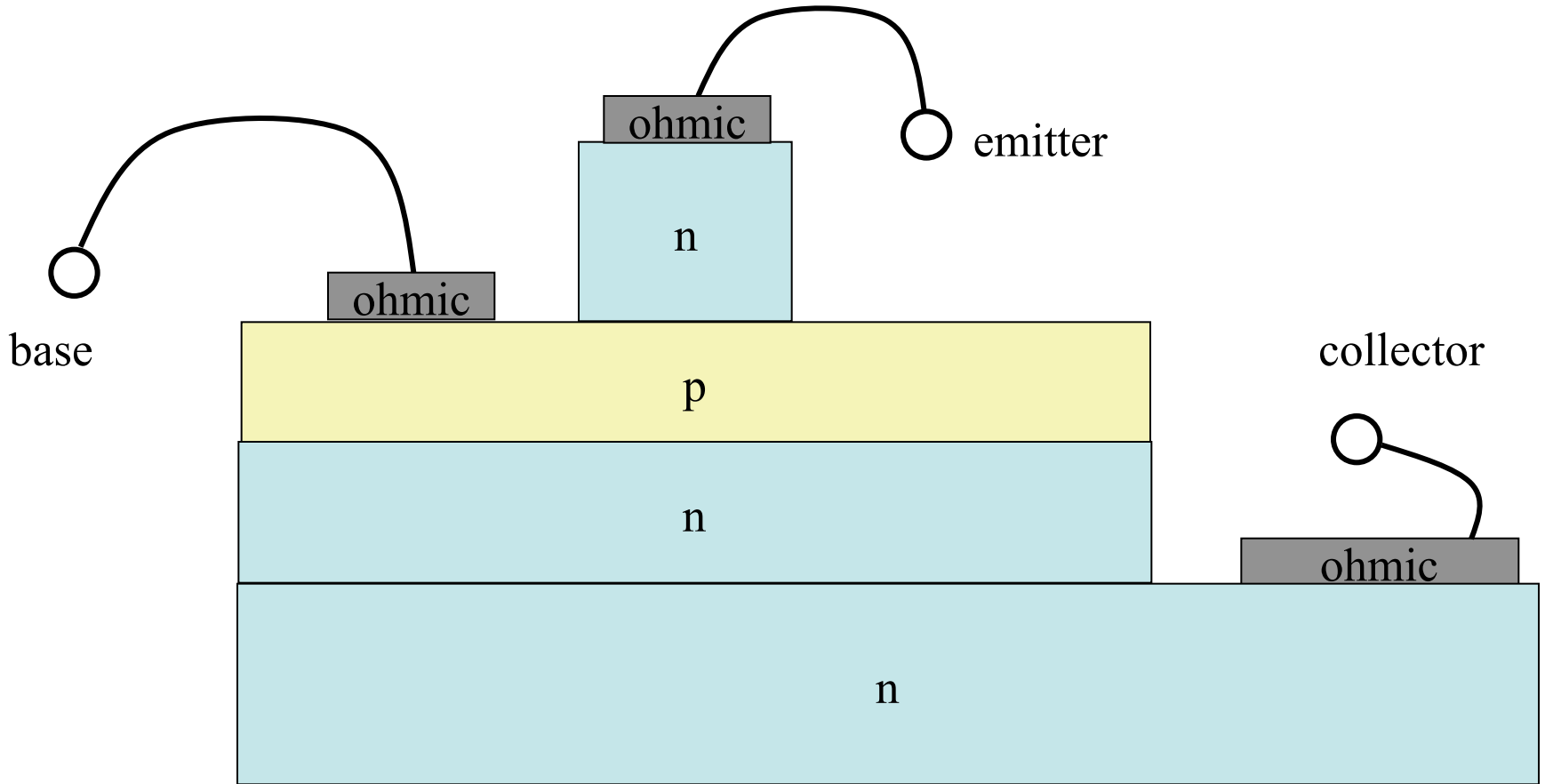

$$R_{E(epi)} = \rho_{E(epi)} \frac{X_{E(epi)}}{L_E W_E} \quad (\text{discuss})$$

Base “epi” resistance:

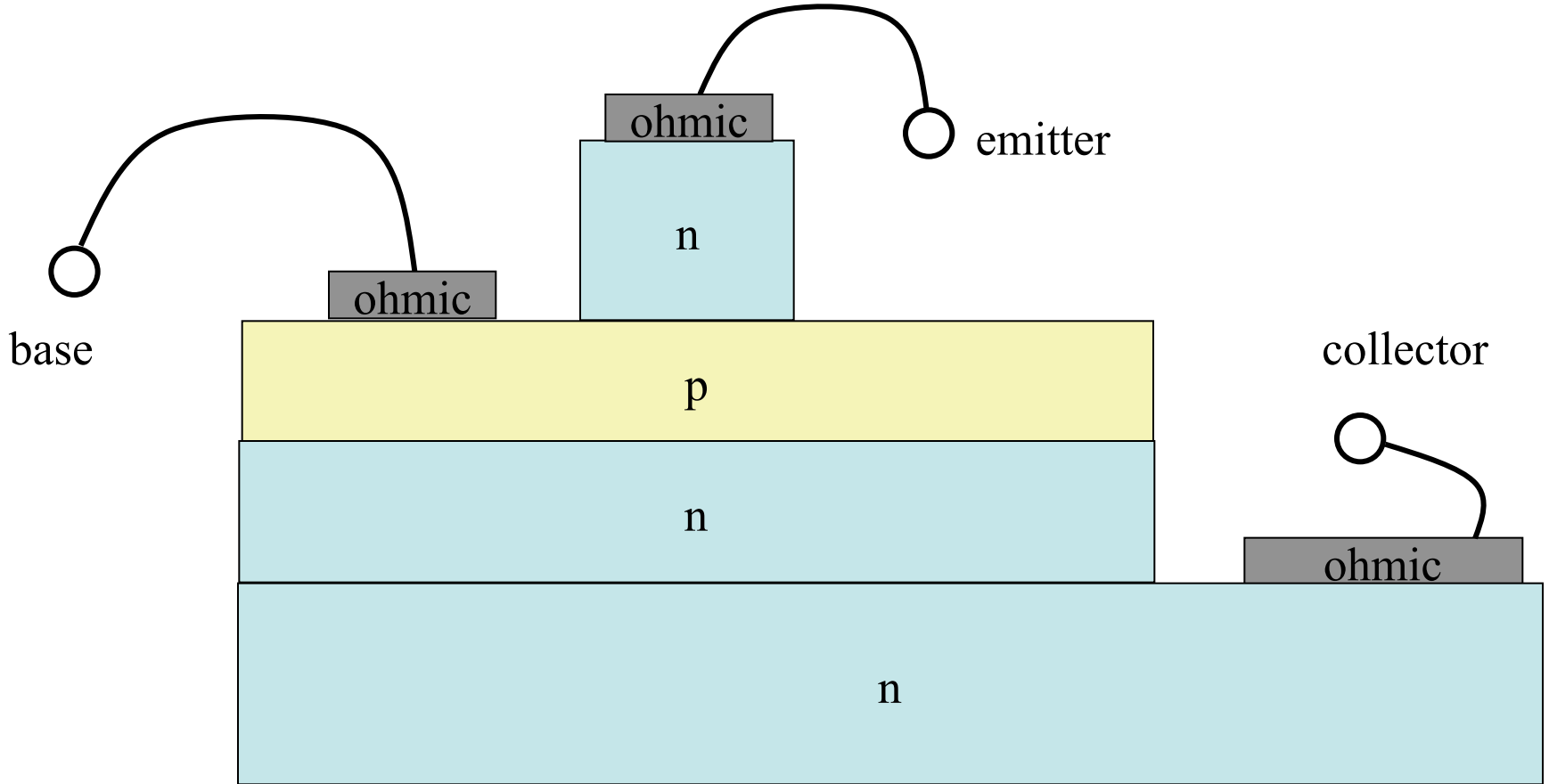

$$R_{Bx(epi)} \quad (\text{discuss})$$

Emitter “epi” resistance:

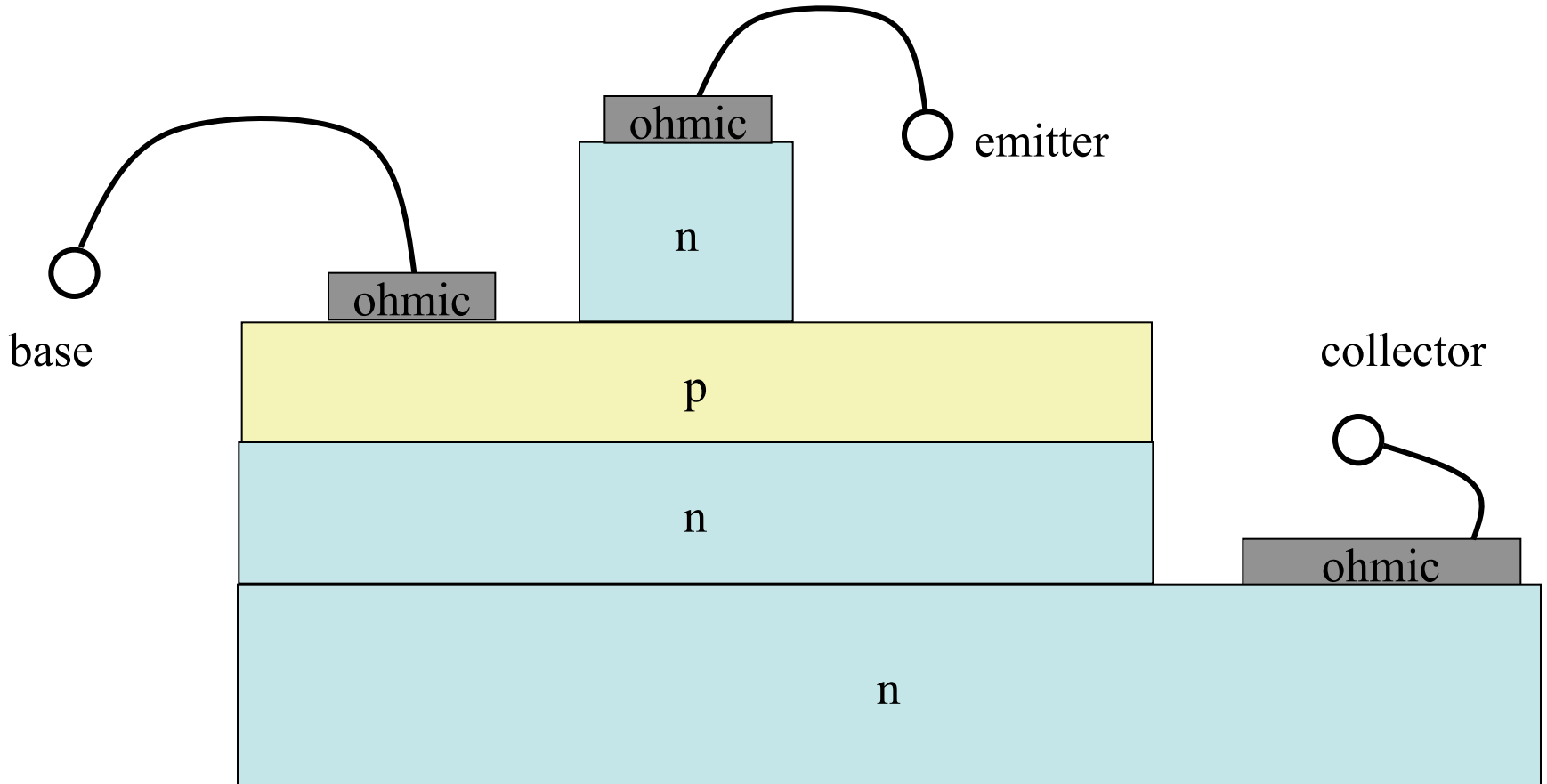

$$R_{E(epi)} = \rho_{E(epi)} \frac{X_{E(epi)}}{L_E W_E} \quad (\text{discuss})$$

Collector “epi” resistance:

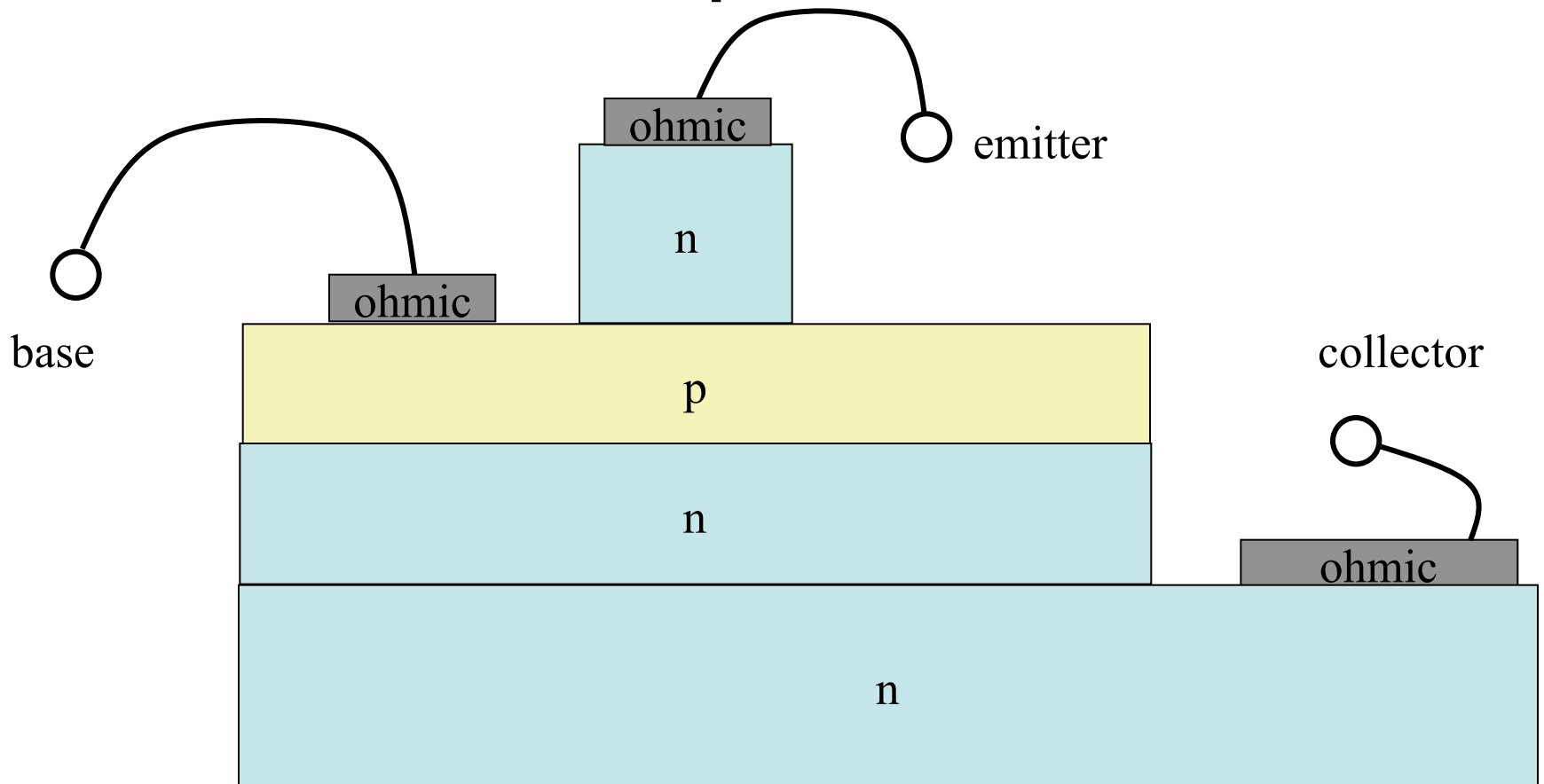

$$R_{C(epi)} = \rho_{C(epi)} \frac{X_{C(epi)}}{L_E W_E}$$

(discuss)

(also discuss spreading effect)

Parasitics: In summary

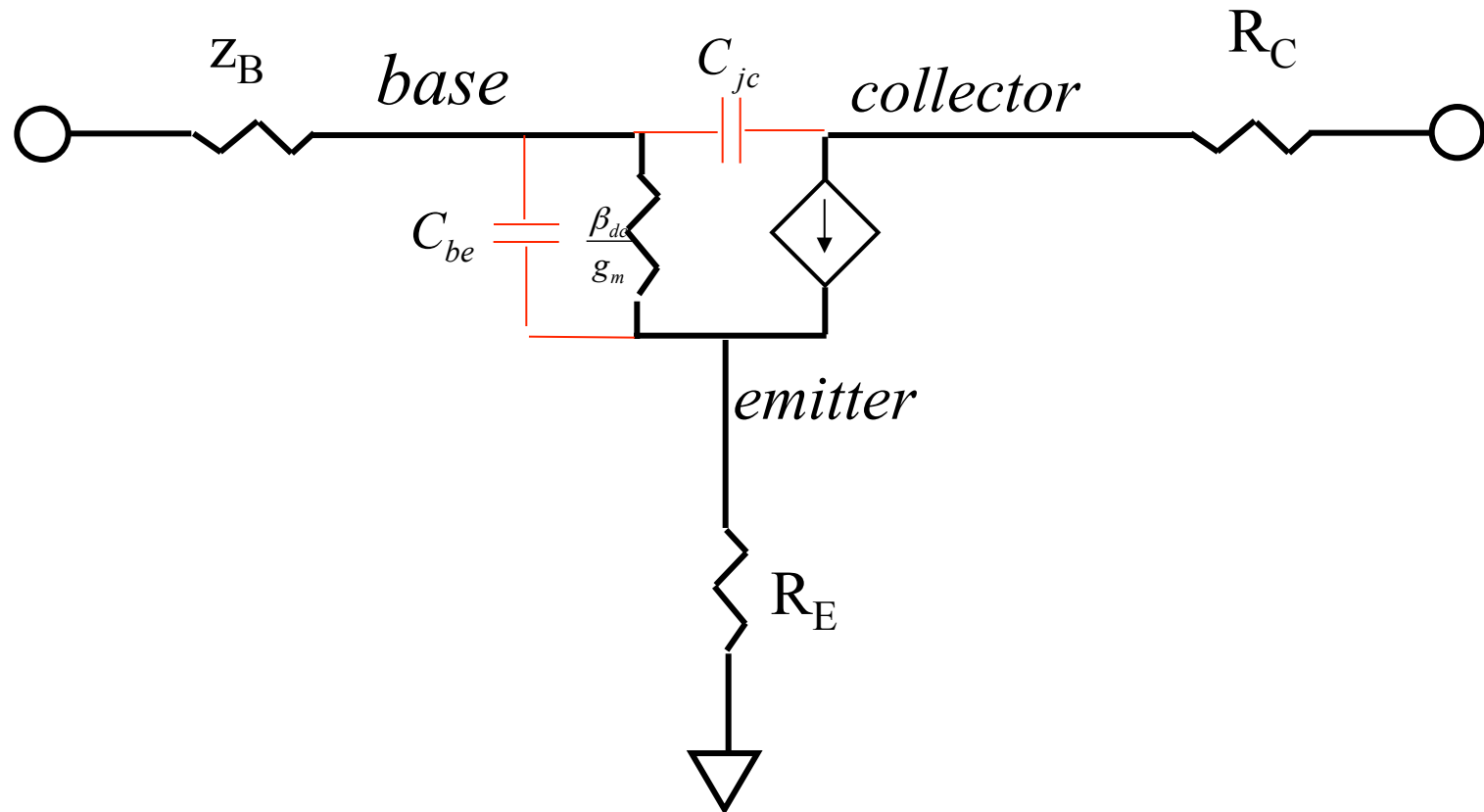

Total parasitics include contact, epi, and metal layer resistance.
Sometimes inductance also added in.

f_T :

$$\begin{pmatrix} v_b \\ i_c \end{pmatrix} = \begin{pmatrix} h_{11e} & h_{12e} \\ h_{21e} & h_{22e} \end{pmatrix} \begin{pmatrix} i_b \\ v_c \end{pmatrix}$$

- Early effect:

Collector voltage changes current gain (β).

- β depends on frequency *and* collector voltage.
- How do we define frequency at which $\beta = 1$?
- At $v_c=0$. This is h_{21e}

$$i_c = h_{21e}i_b + h_{22e}v_c \rightarrow h_{21e}i_b$$

- We define f_T such that:

$$|h_{21e}(f_T)| = 1$$

$$f_T = \frac{1}{2\pi\tau_{ec}}$$

$$\tau_{ec} = \tau_e + \tau_b + \tau_{sc} + \tau_c$$

Emitter charging time

$$\tau_e = \frac{kT}{eI_C} (C_{je} + C_{jc})$$

Time to charge up junction capacitors.

Base transit time

$$\tau_e = \frac{X_B^2}{2D_{nB}}$$

Time to charge up base minority carriers.
Or: time to diffuse from emitter to collector.
(Built in field helps a lot here.)

Space-charge transit time

$$\tau_e = \frac{X_{dep}}{2v_{sat}}$$

Or: time to *drift* through space charge of base-collector junction.

Collector charging time

$$\tau_c = (R_E + R_C) \cdot C_{jc}$$

Time to charge collector junction capacitor through parasitic resistors.

f_T :

$$\begin{pmatrix} v_b \\ i_c \end{pmatrix} = \begin{pmatrix} h_{11e} & h_{12e} \\ h_{21e} & h_{22e} \end{pmatrix} \begin{pmatrix} i_b \\ v_c \end{pmatrix}$$

“It can be shown that...”

$$h_{21e} = \frac{\alpha_{T0}}{(1 - \alpha_{T0}) + i(f / f_T)} \quad \alpha_{T0} \equiv 1 - \frac{X_B^2}{2L_n^2}$$

Discuss rolloff, low frequency value.

f_{\max} :

In real circuits, we do not want to short circuit the output!

Unilateral power gain: if impedance matching network is set up so that there is no reverse transmission ($S_{12}=0$), in that case the power gain is called the *unilateral power gain*.

“It can be shown that...”

$$U = \frac{|z_{21} - z_{12}|^2}{4[\operatorname{Re}(z_{11})\operatorname{Re}(z_{22}) - \operatorname{Re}(z_{12})\operatorname{Re}(z_{21})]}$$

“It can be shown that...”

$$U = \frac{\alpha_{T0}^2 \omega_T}{4 \operatorname{Re}(z_b) C_{jc} \omega^2}$$

$$f_{\max} = \sqrt{\frac{f_T}{8\pi r_b C_{jc}}}$$

Discuss r_b dependence,
want heavily doped base.
Need for *HBT*.