

# Lecture 7: Field Effect Devices

- MOSFET
- JFET
- MESFET
- HEMT

# Si MOSFET:

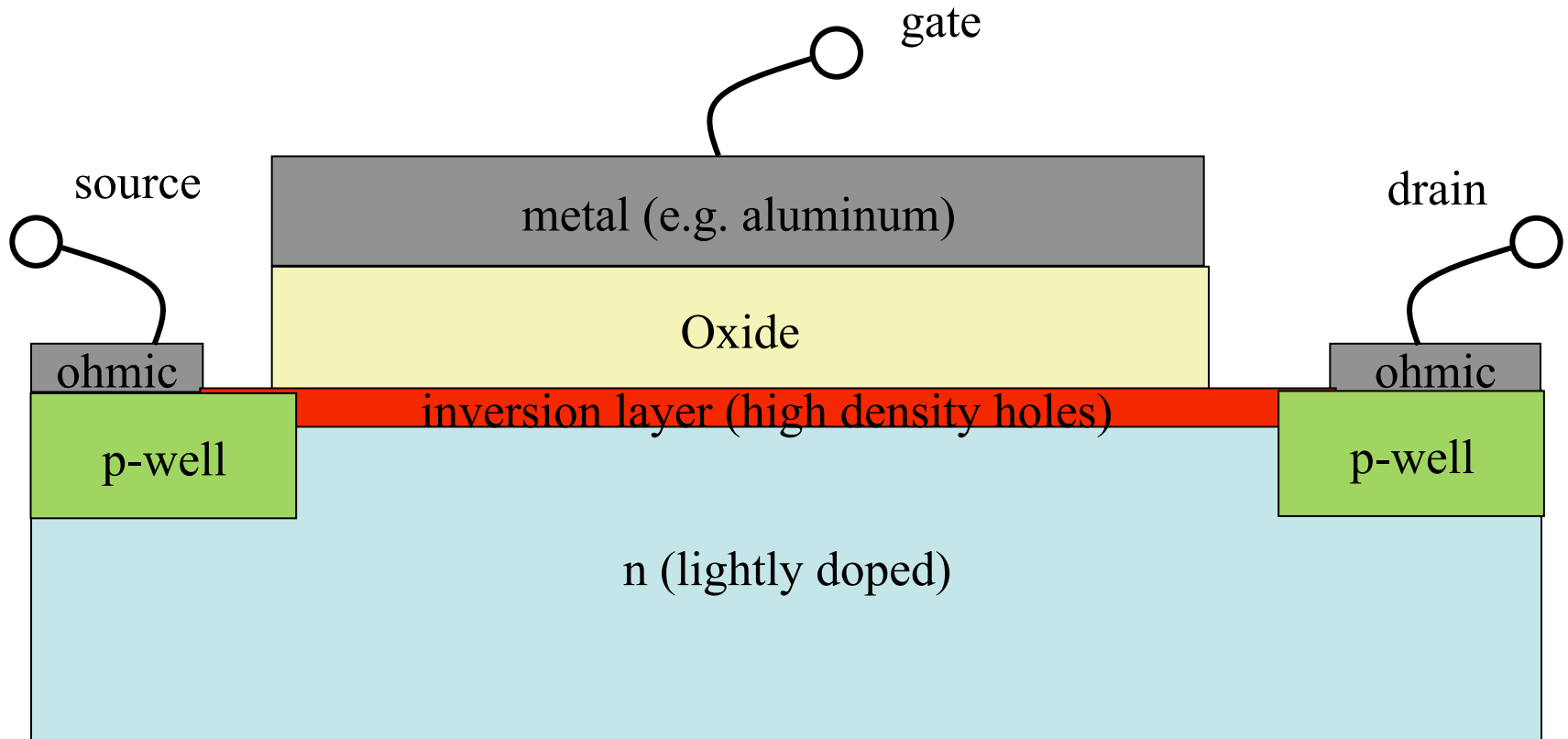

- Gate has high input resistance ( $10^{12} \Omega$ )
- Si covered in ECE 277A.
- No oxide for GaAs, so need different type of device.

# Non-oxide transistors

- JFET: Junction Field Effect Transistor
- MESFET: Metal Electron Semiconductor Field Effect Transistor
- HEMT: High Electron Mobility Transistor
  - Also called:
    - MODFET Modulation Doped Field Effect Transistor
    - TEGFET Two-Dimensional Electron Gas Field Effect Transistor
    - pHEMT Pseudomorphic HEMT
    - HFET Heterojunction Field Effect Transistor

# Electric field

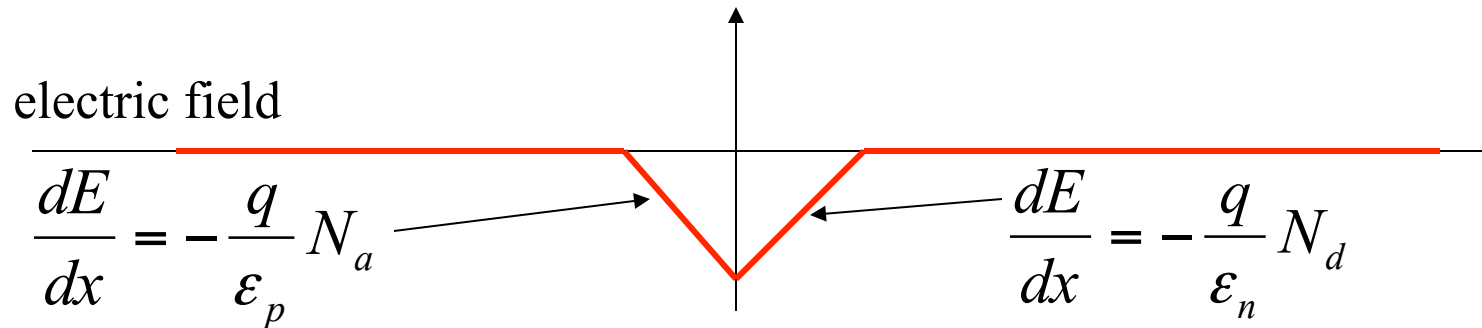
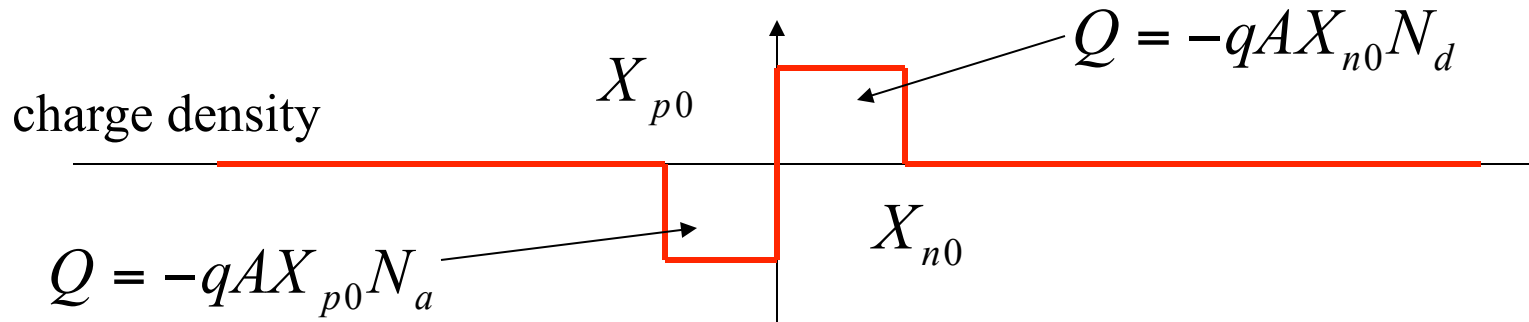

$$E(x) = -\frac{q}{\epsilon_p} N_a (x + X_{p0})$$

$$E(x) = -\frac{q}{\epsilon_p} N_d (X_{n0} - x)$$

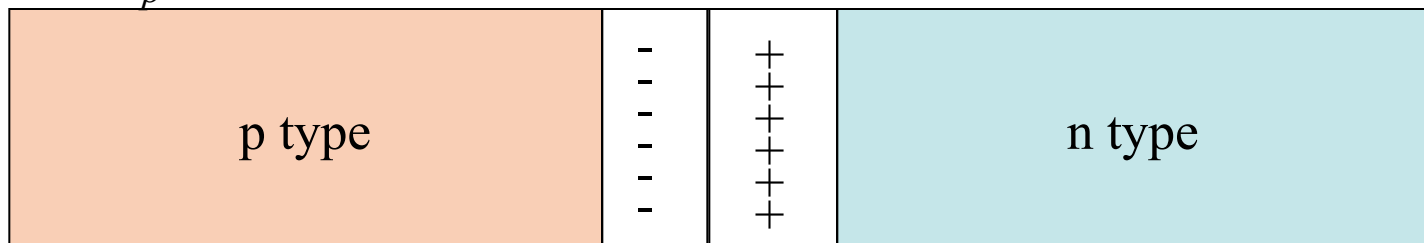

# Under Bias:

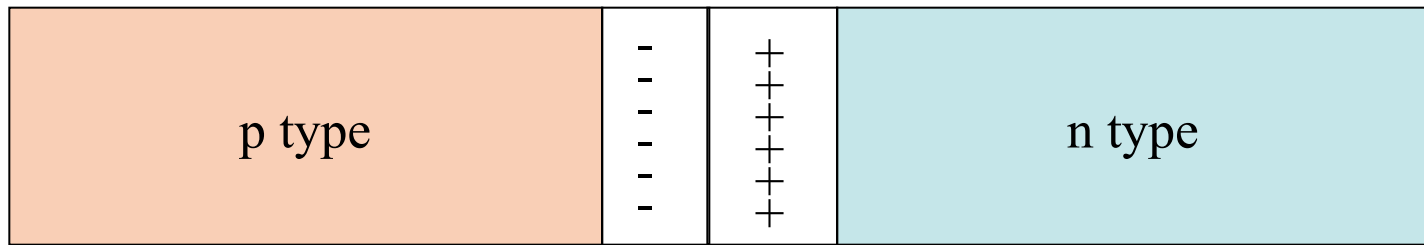
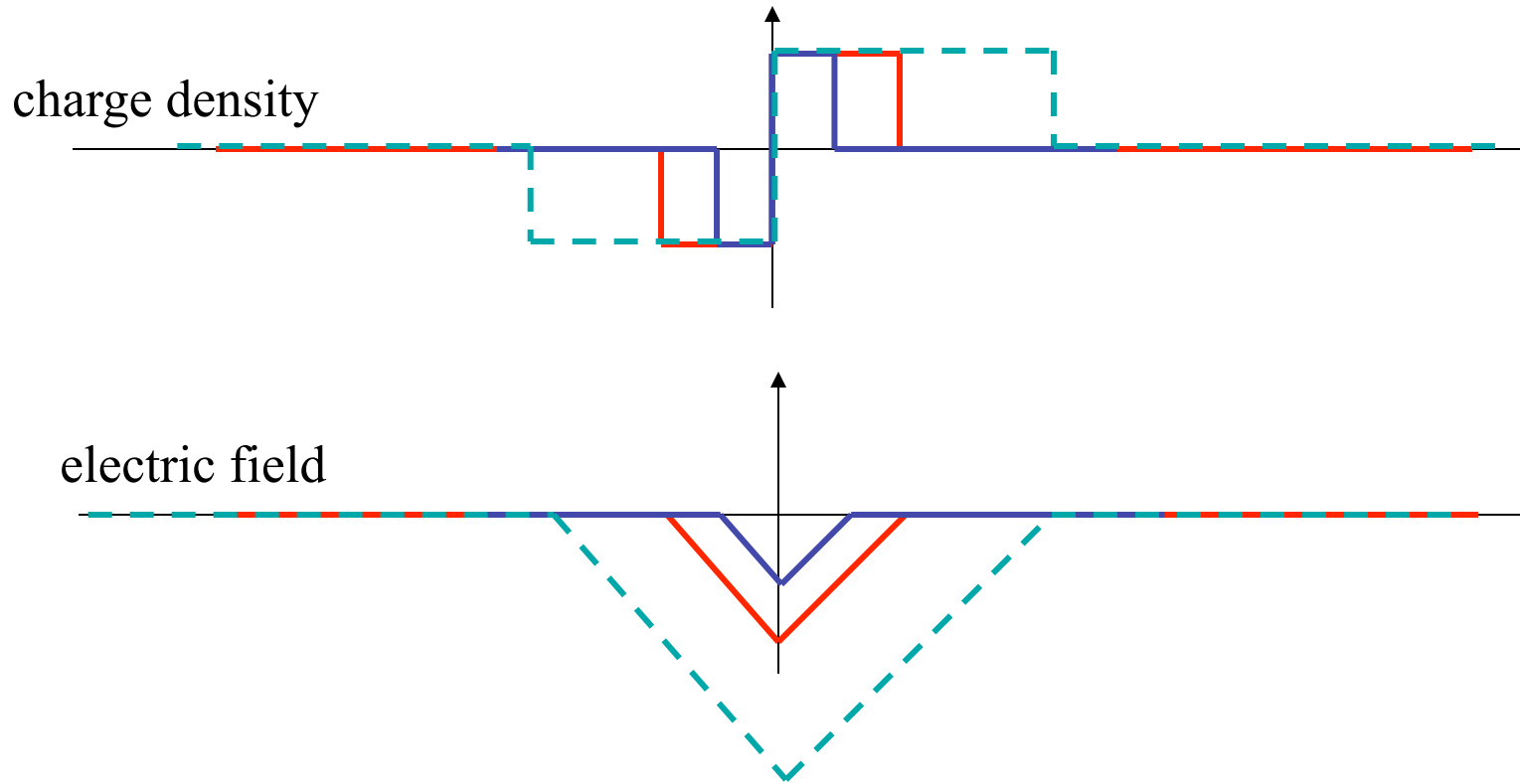

# JFET:

- Like MOSFET, but no oxide
- Gate looks like diode: Don't forward bias!

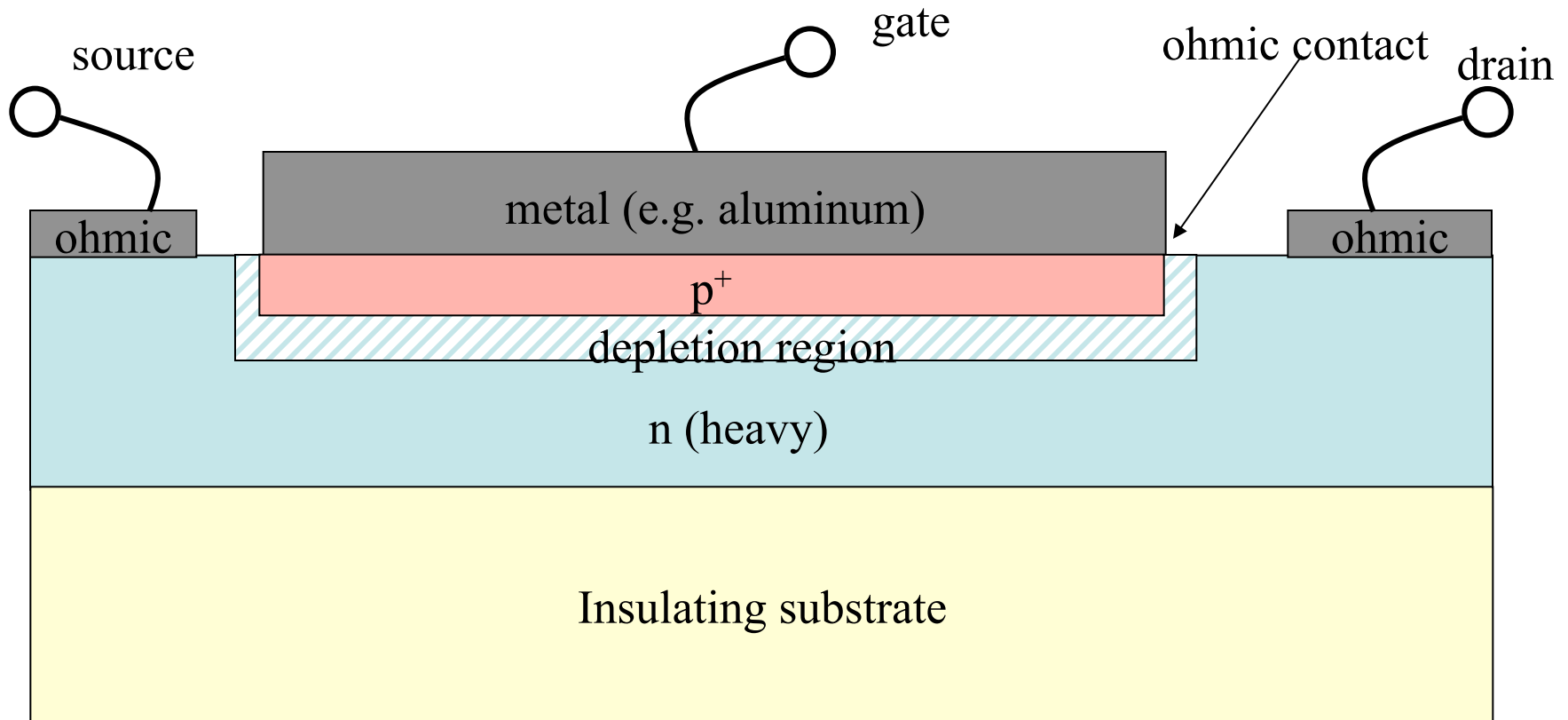

# JFET:

$$V_{\text{gate}} = -5 \text{ V}$$

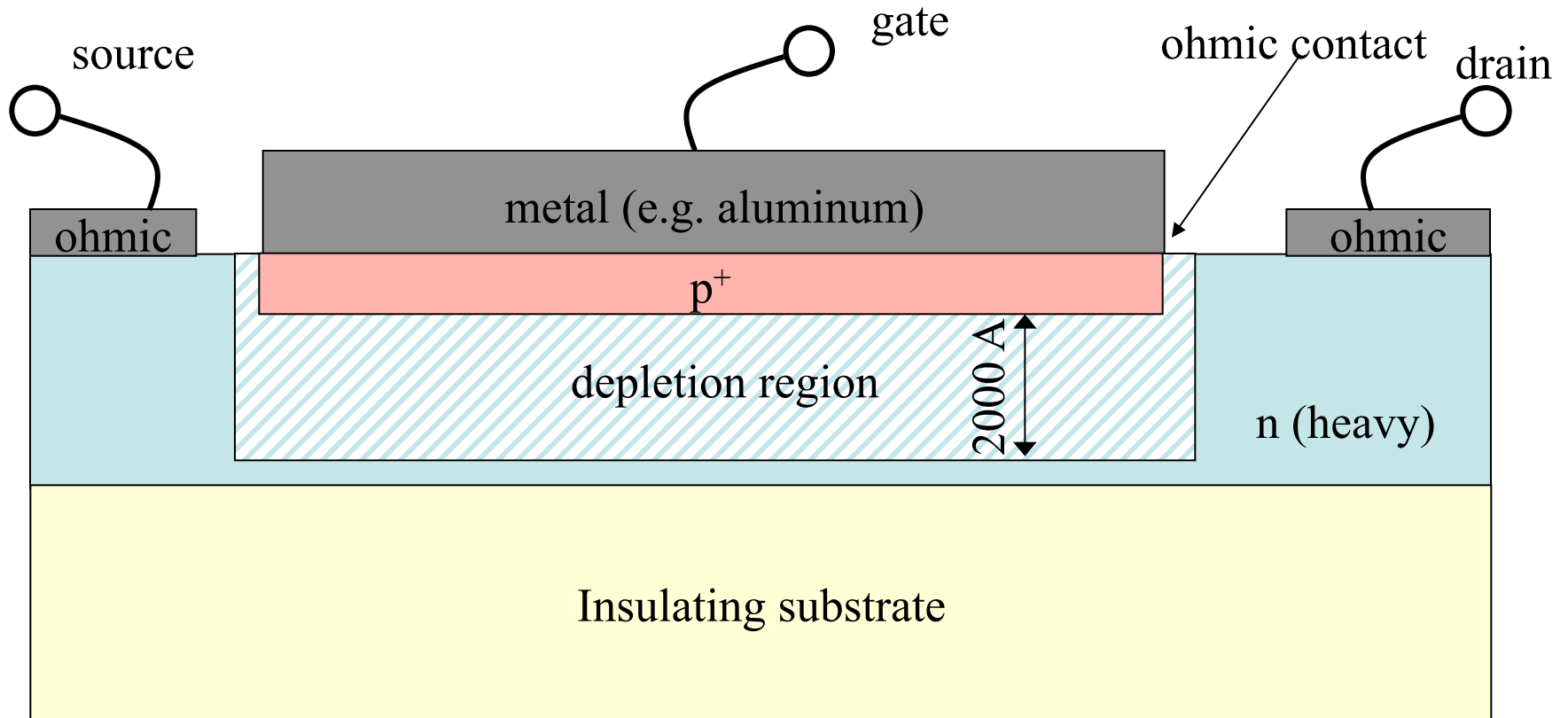

# JFET:

$$V_{\text{gate}} = -5 \text{ V}$$
$$V_{\text{sd}} > 0$$

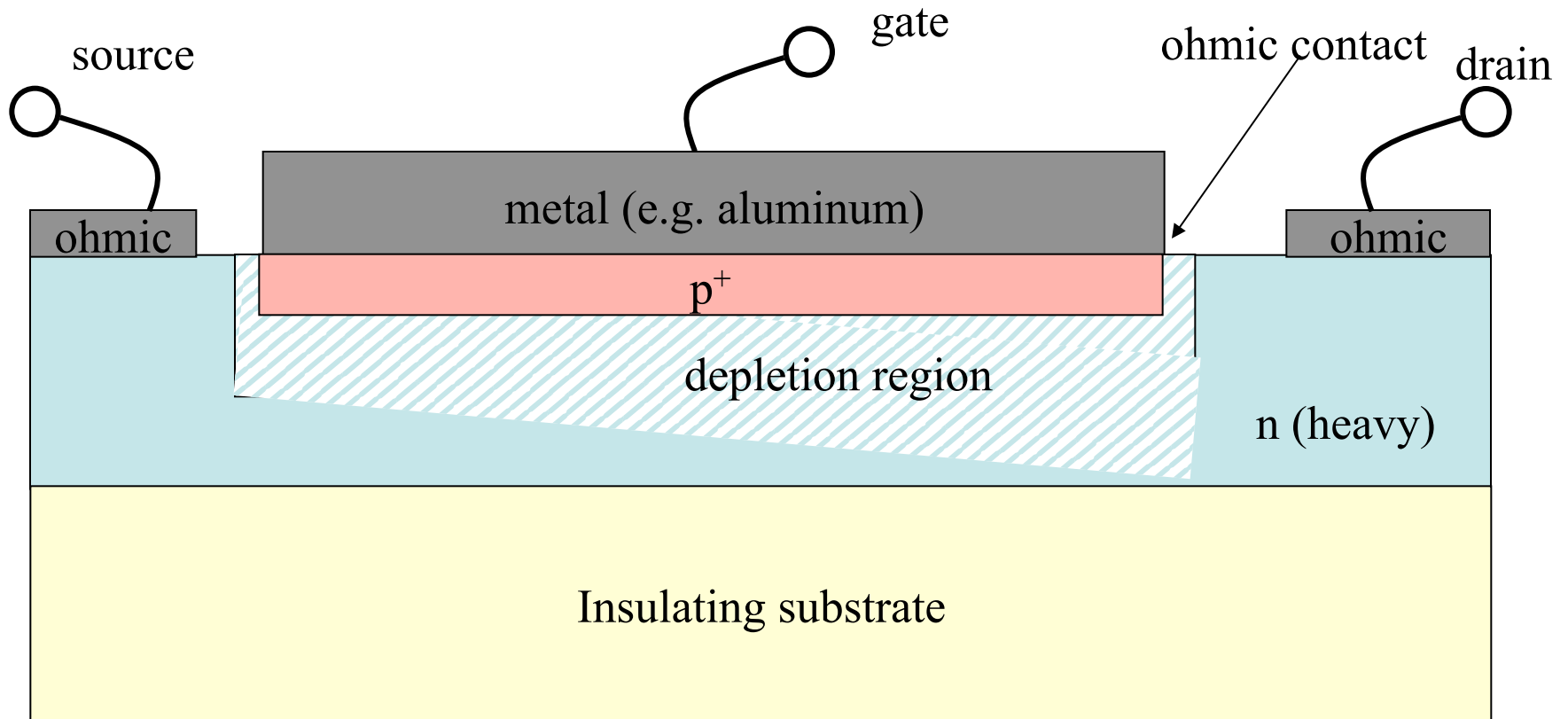



# MESFET:

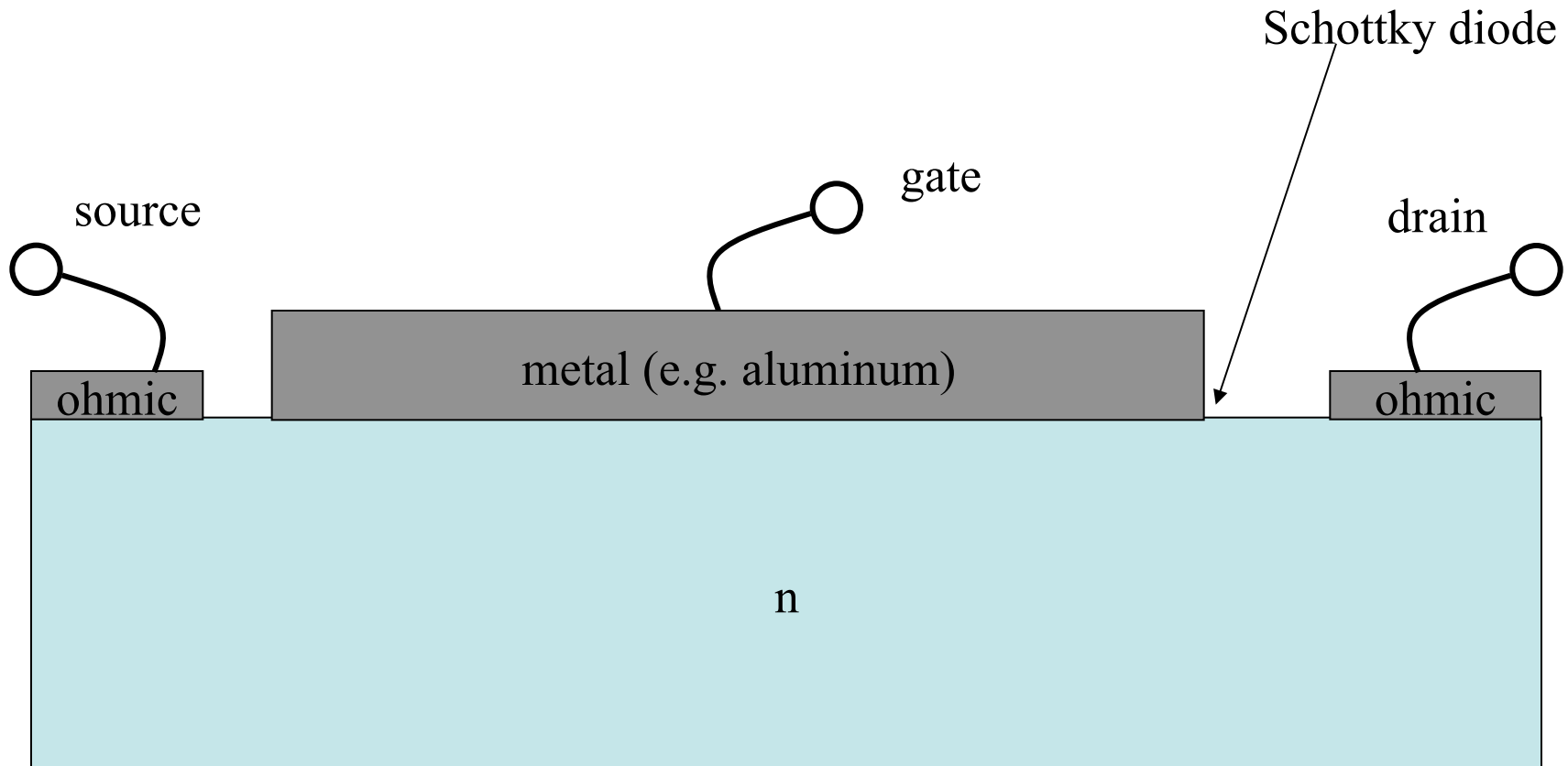

- Like MOSFET, but no oxide
- Gate looks like Schottky diode: Don't forward bias!

# Schottky barriers

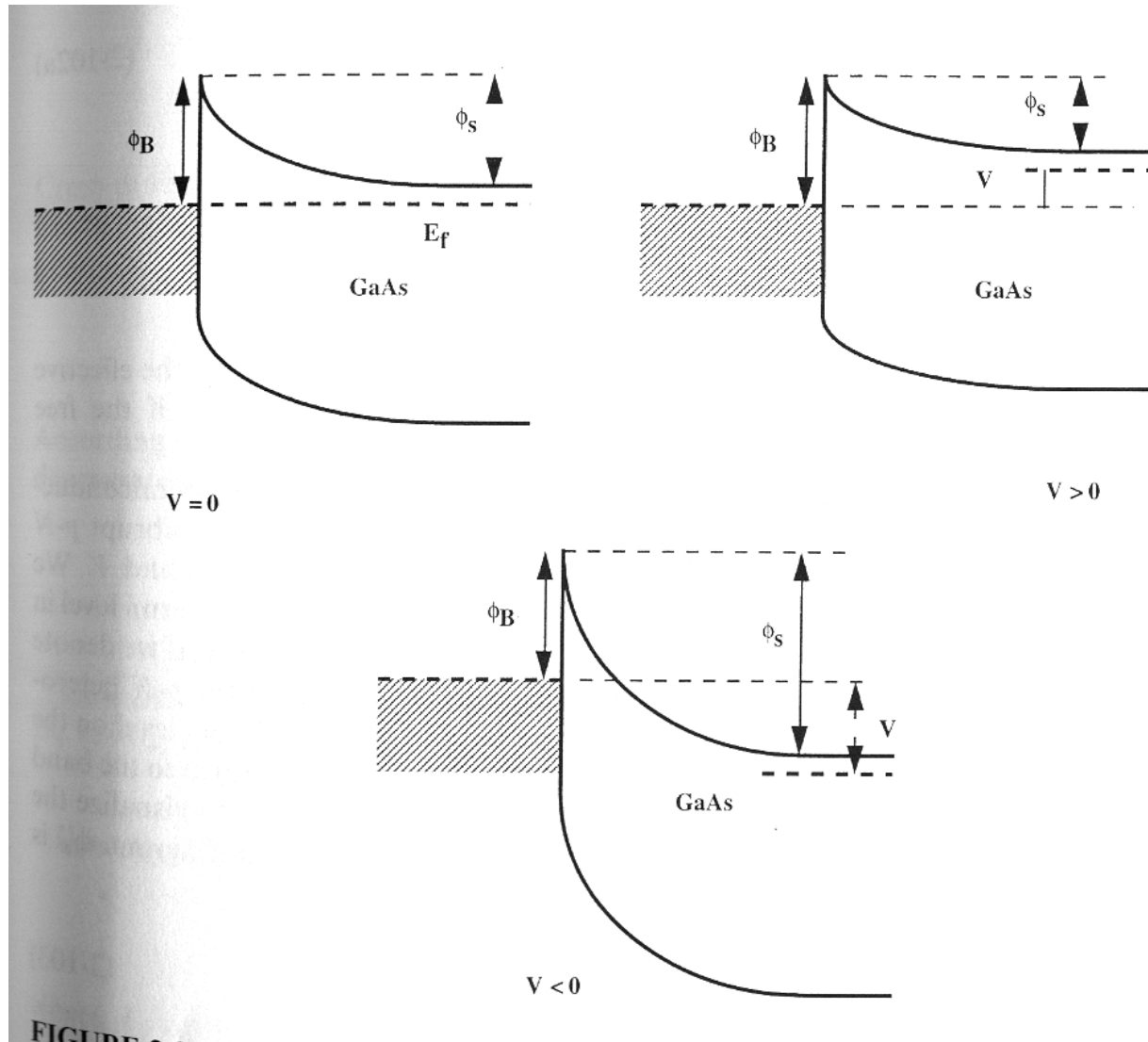

From Liu

# Schottky depletion region

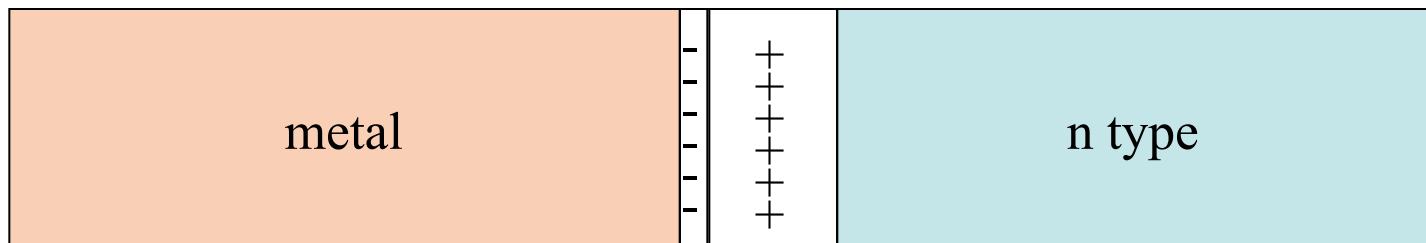
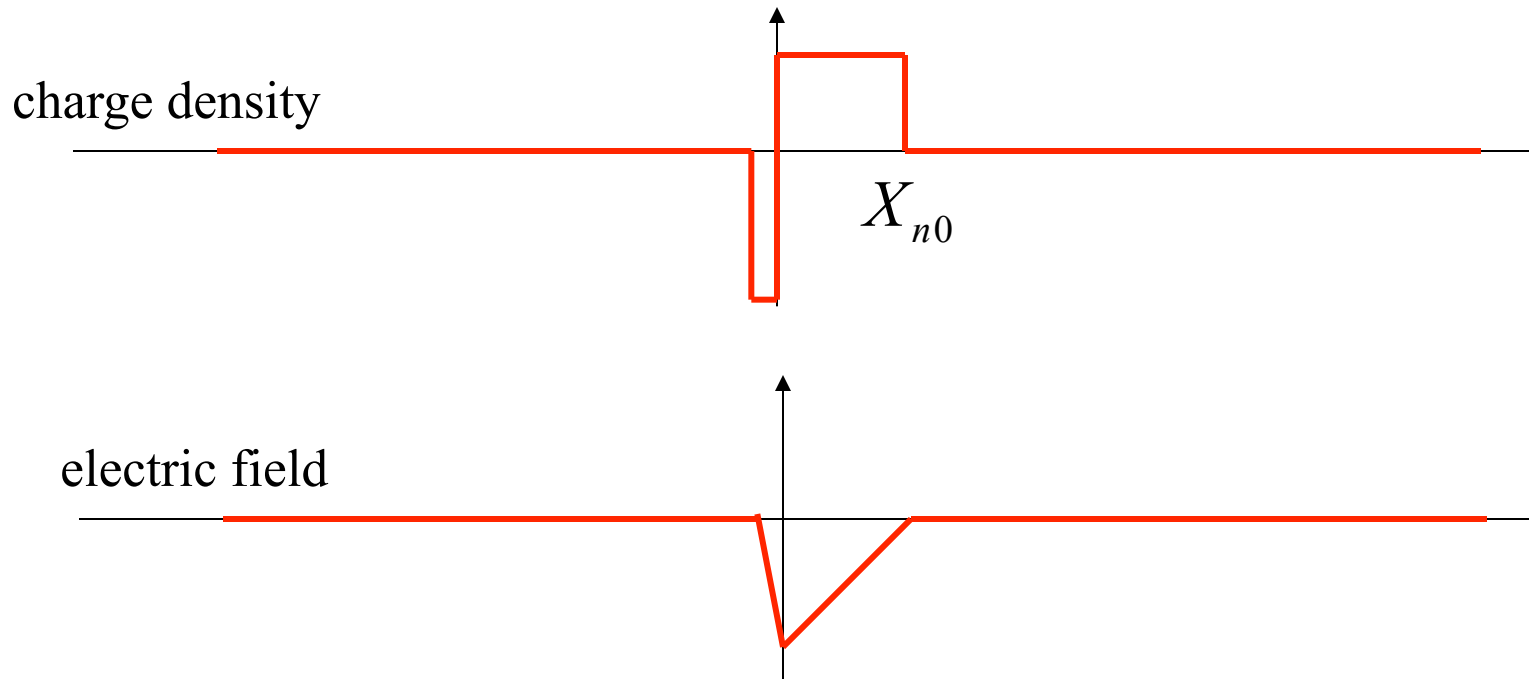

# Schottky under bias

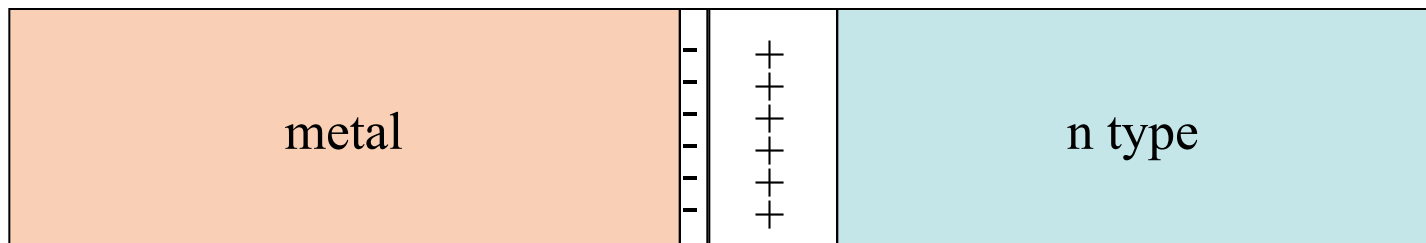
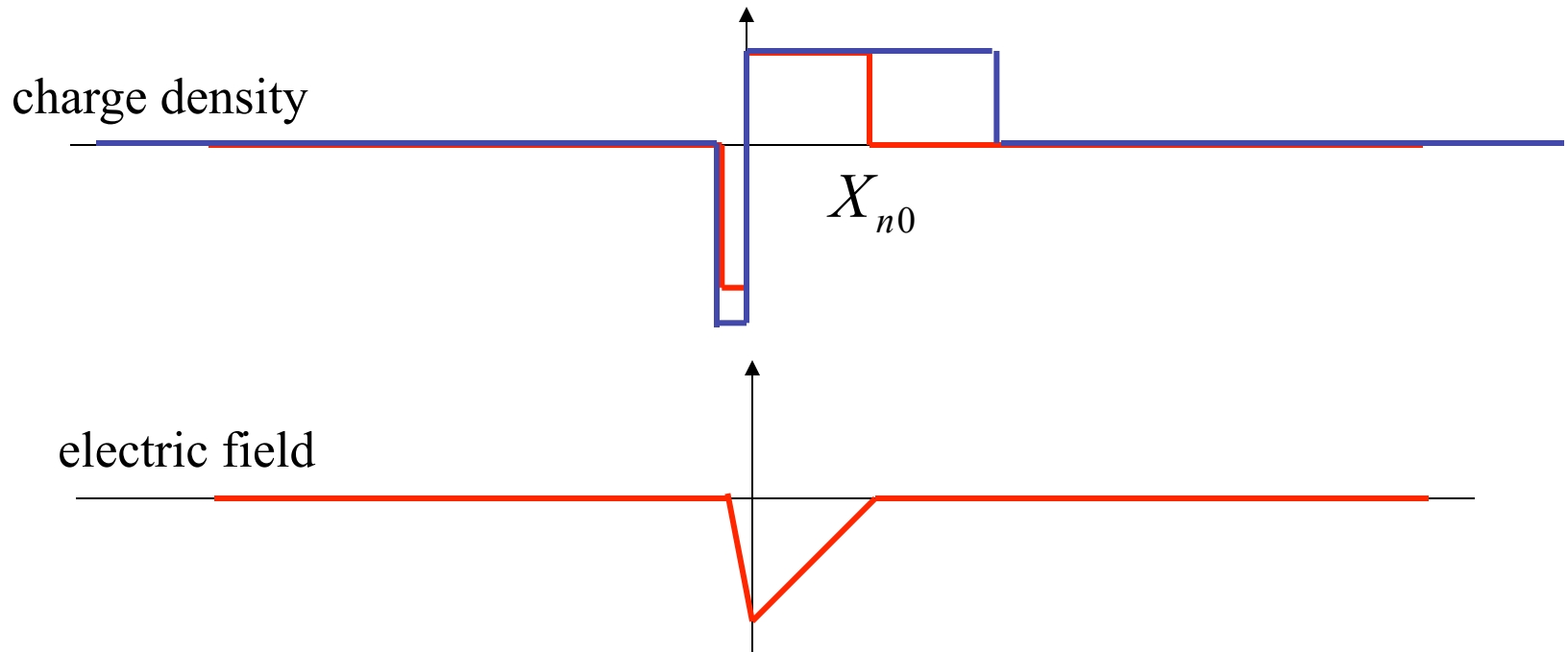

# MESFET:

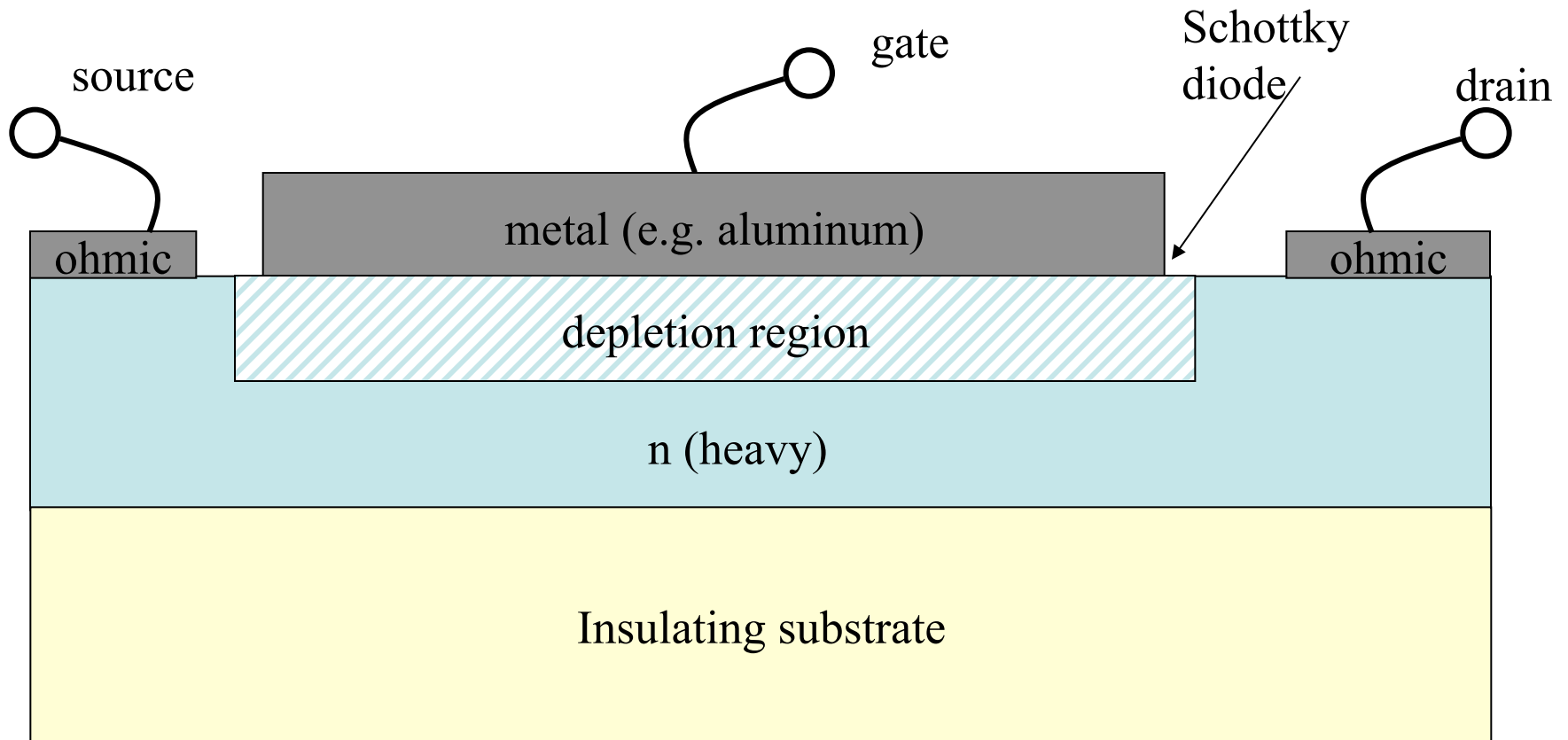

# MESFET:

$$V_{\text{gate}} = -5 \text{ V}$$

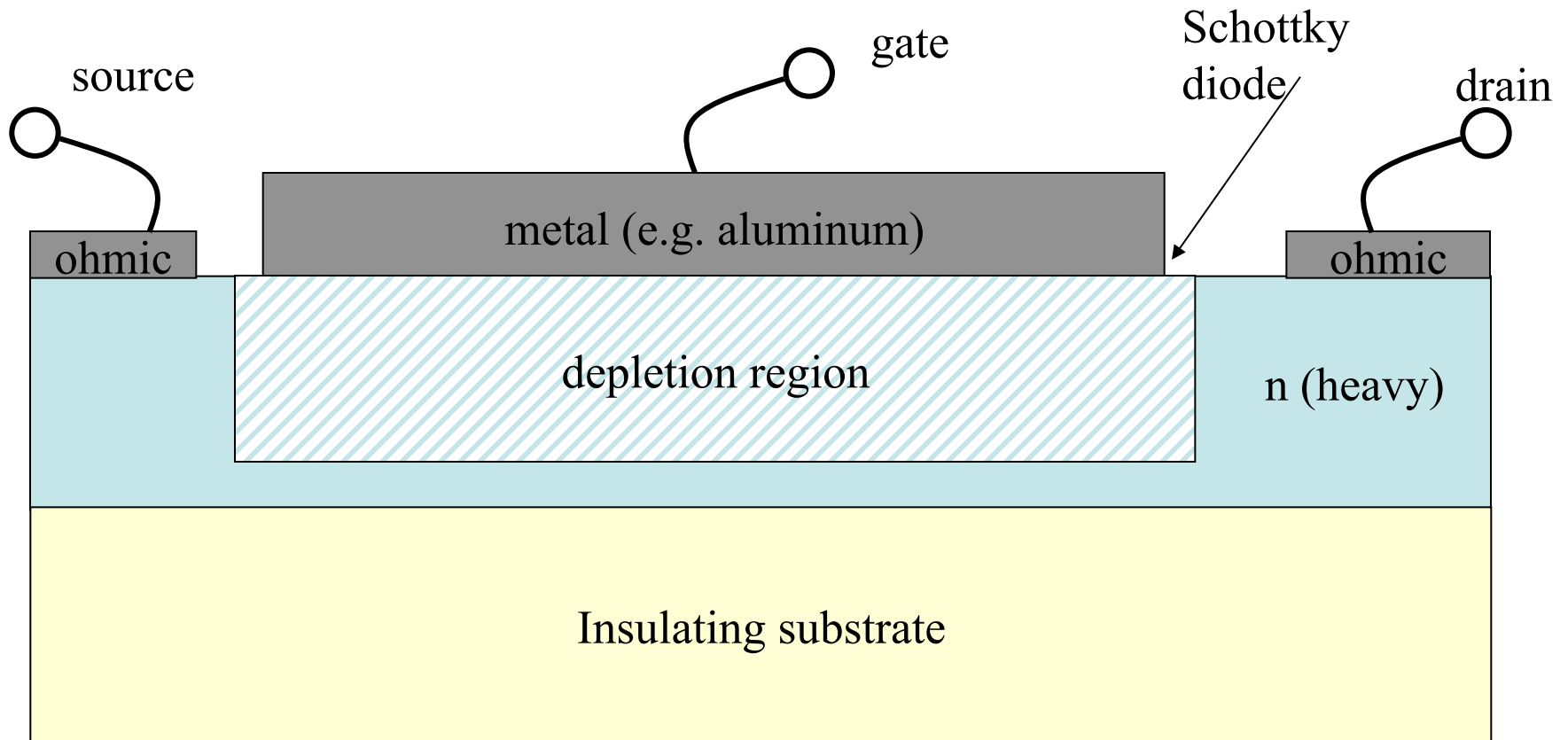

# MESFET:

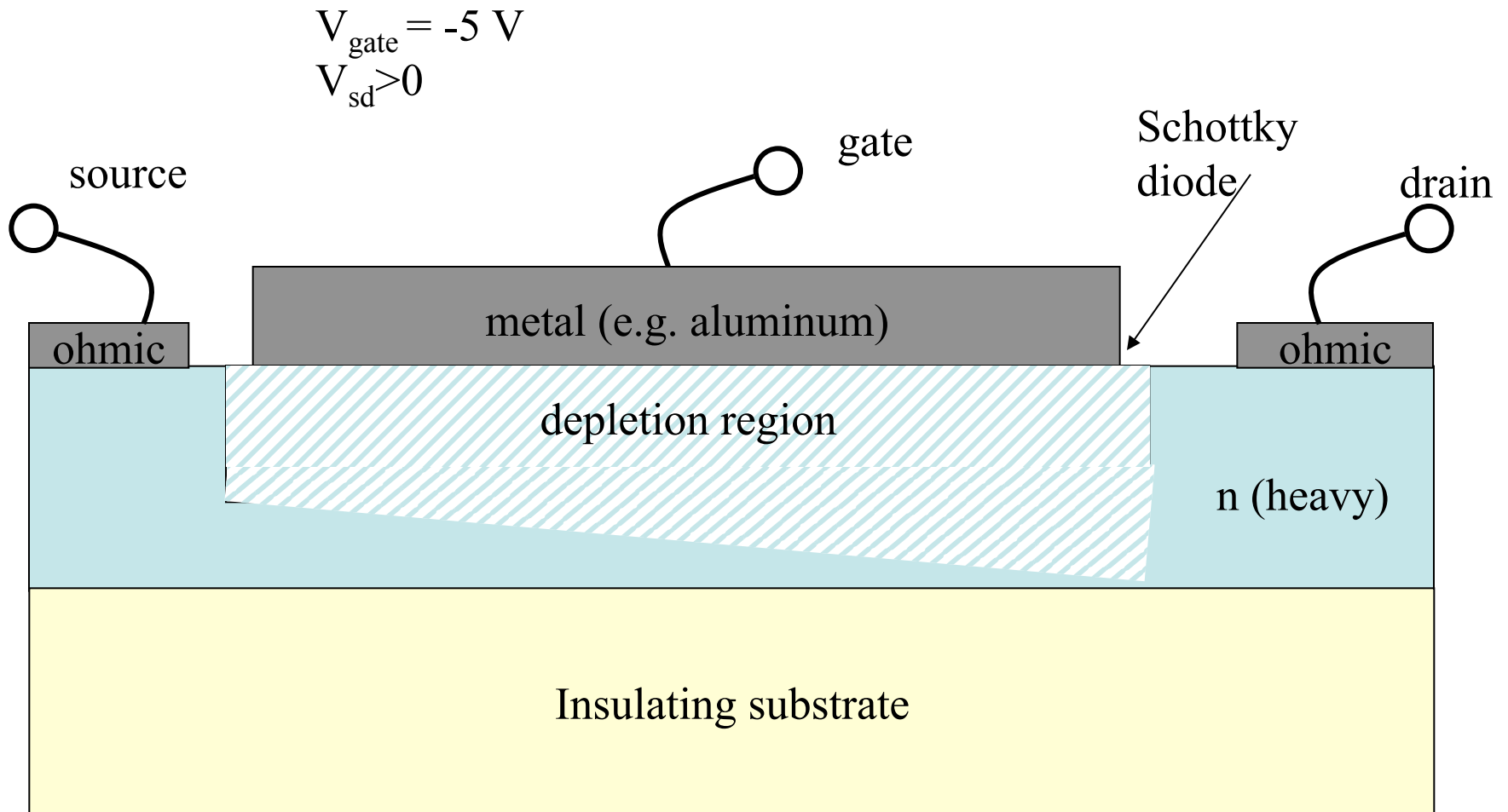

# Transistor performance

- Want a lot of current: heavy doping
- Want high mobility for high  $f_T$
- Heavy doping degrades mobility
- Solution: donors physically in different location than electrons: HEMT



# “Mobility”

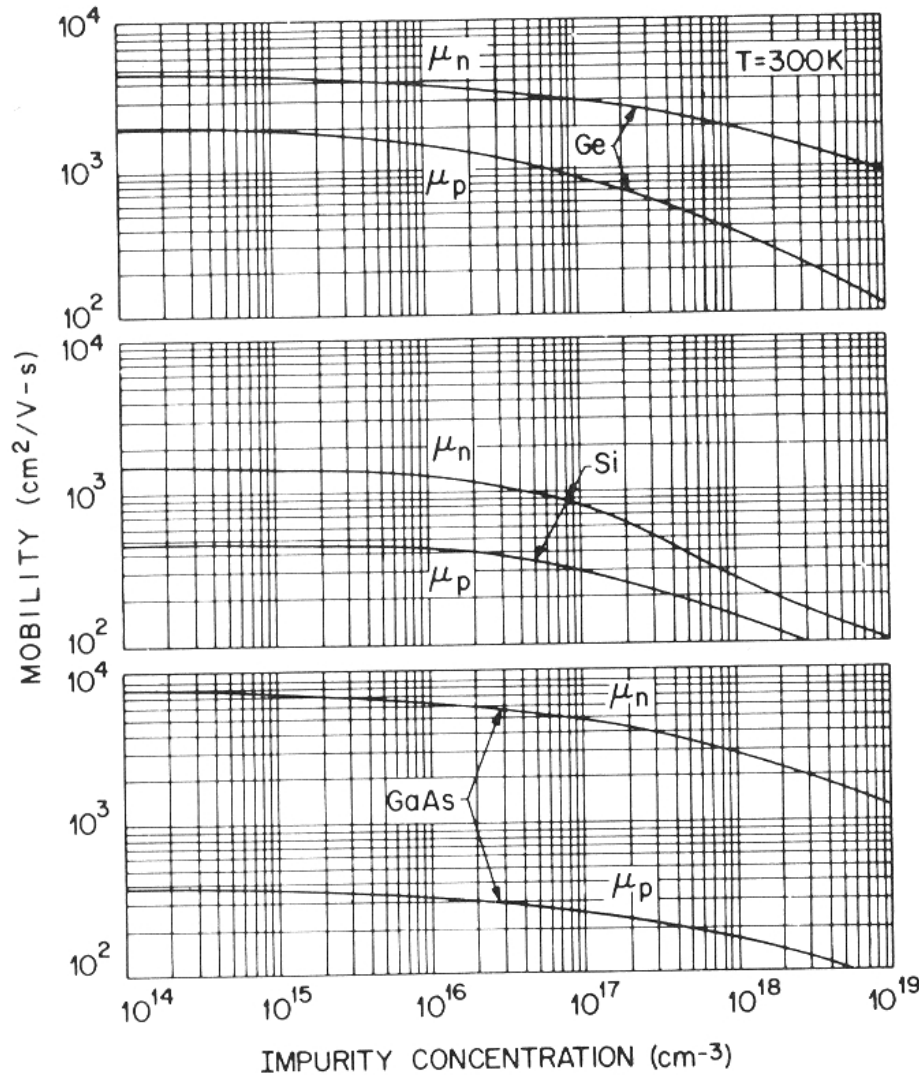

At low impurity concentration, electron-phonon scattering dominates.

At high impurity concentration, impurity scattering dominates.

$$\frac{1}{\tau_{total}} = \frac{1}{\tau_{electron-phonon}} + \frac{1}{\tau_{impurity}}$$

From Sze, Physics of Semiconductor Devices

# HEMT:

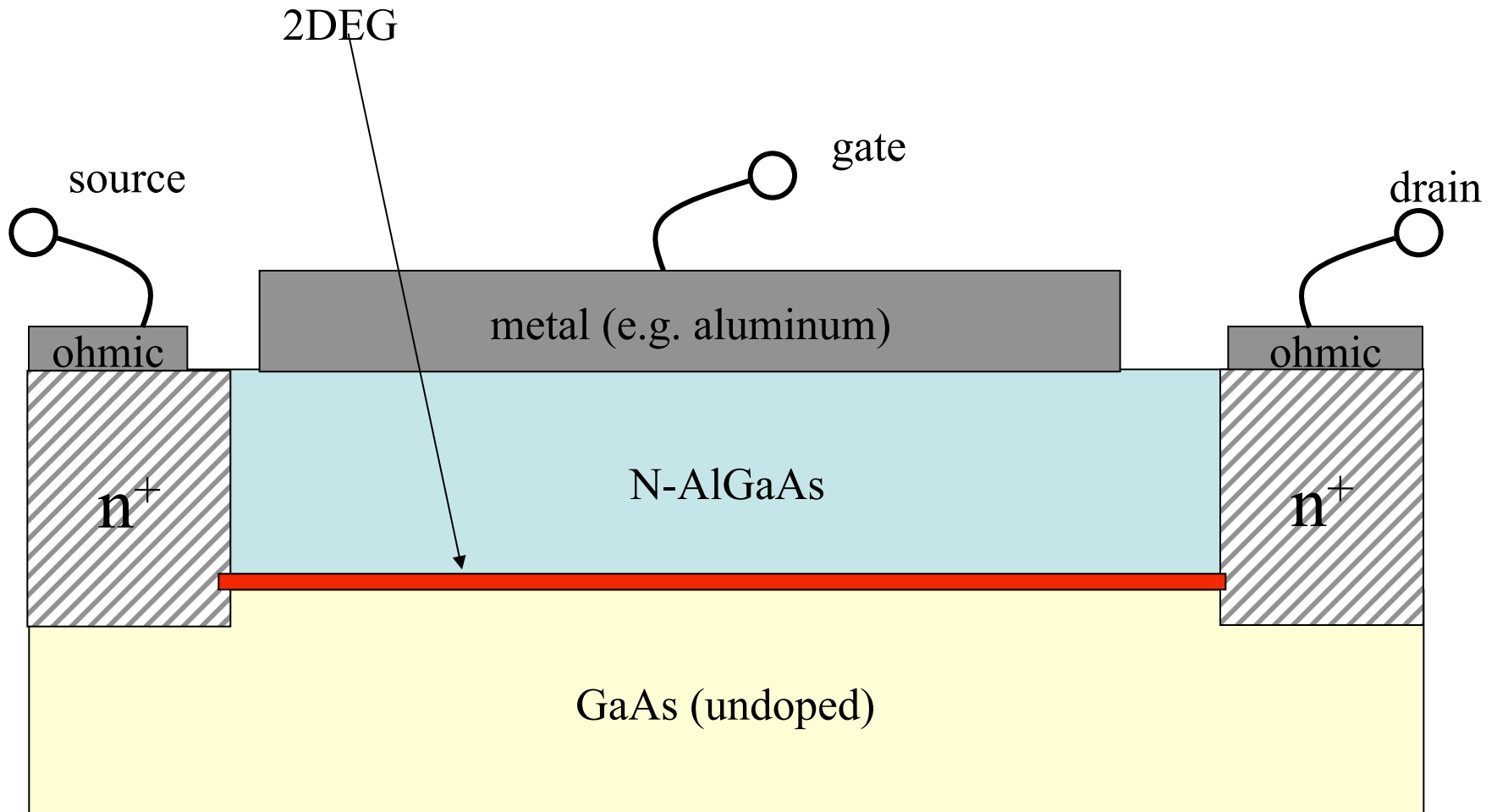

# Band diagram

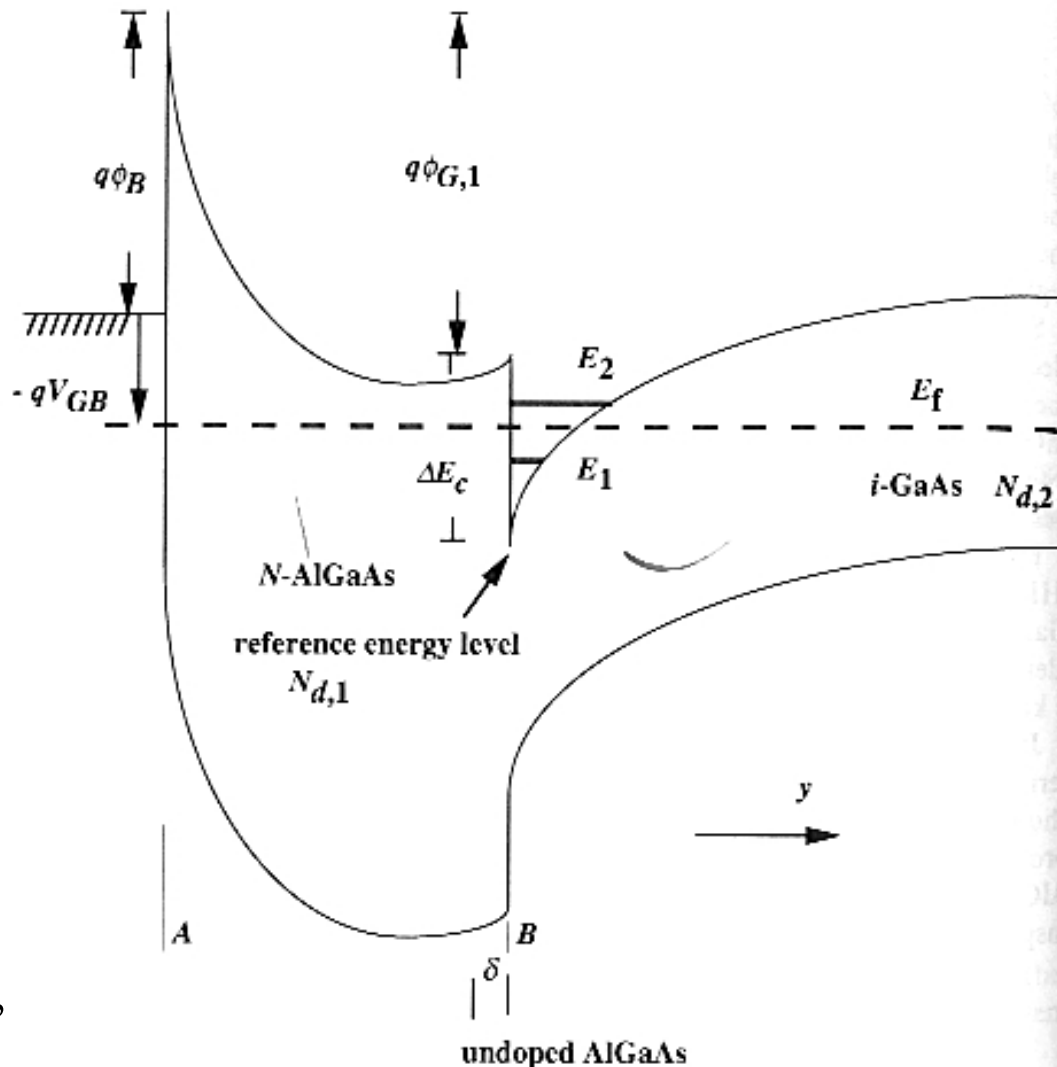

- Bias changes Fermi level
- hence density.
- Can “pinchoff”

From Liu.

# MBE

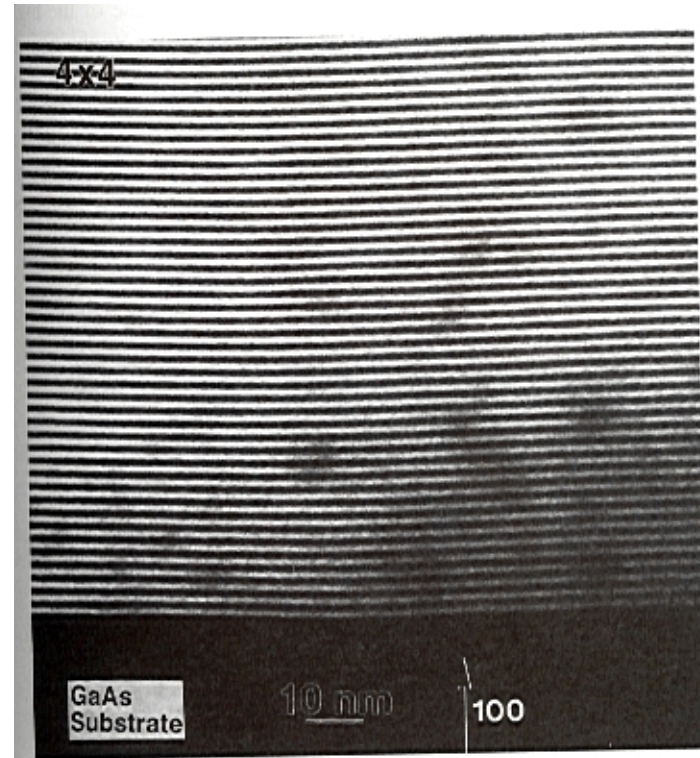
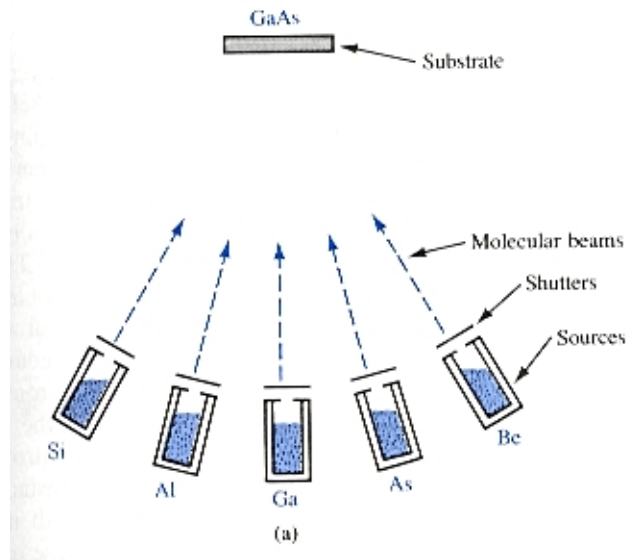

4 atom per layer!

(From Streetman, Solid State Electronic Devices)

# MBE

epitaxial growth

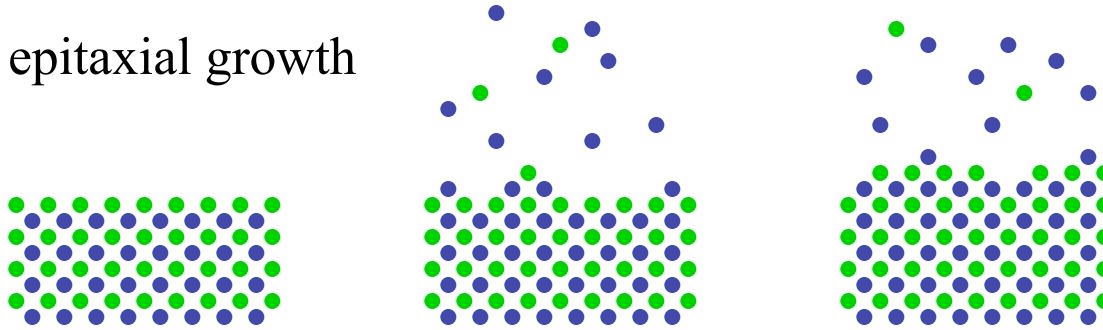

AlAs

GaAs

AlAs

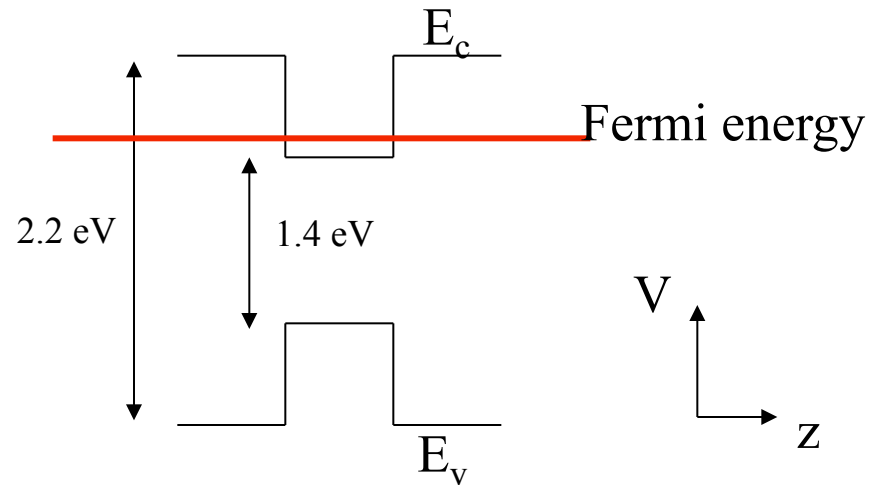
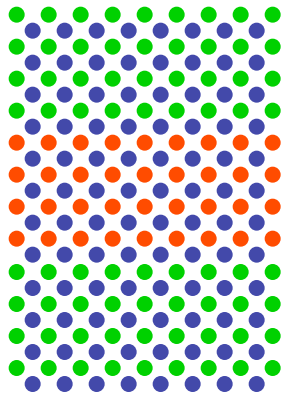

Also InP, InGaAs, InAlAs, InGaAsP

# HEMT:

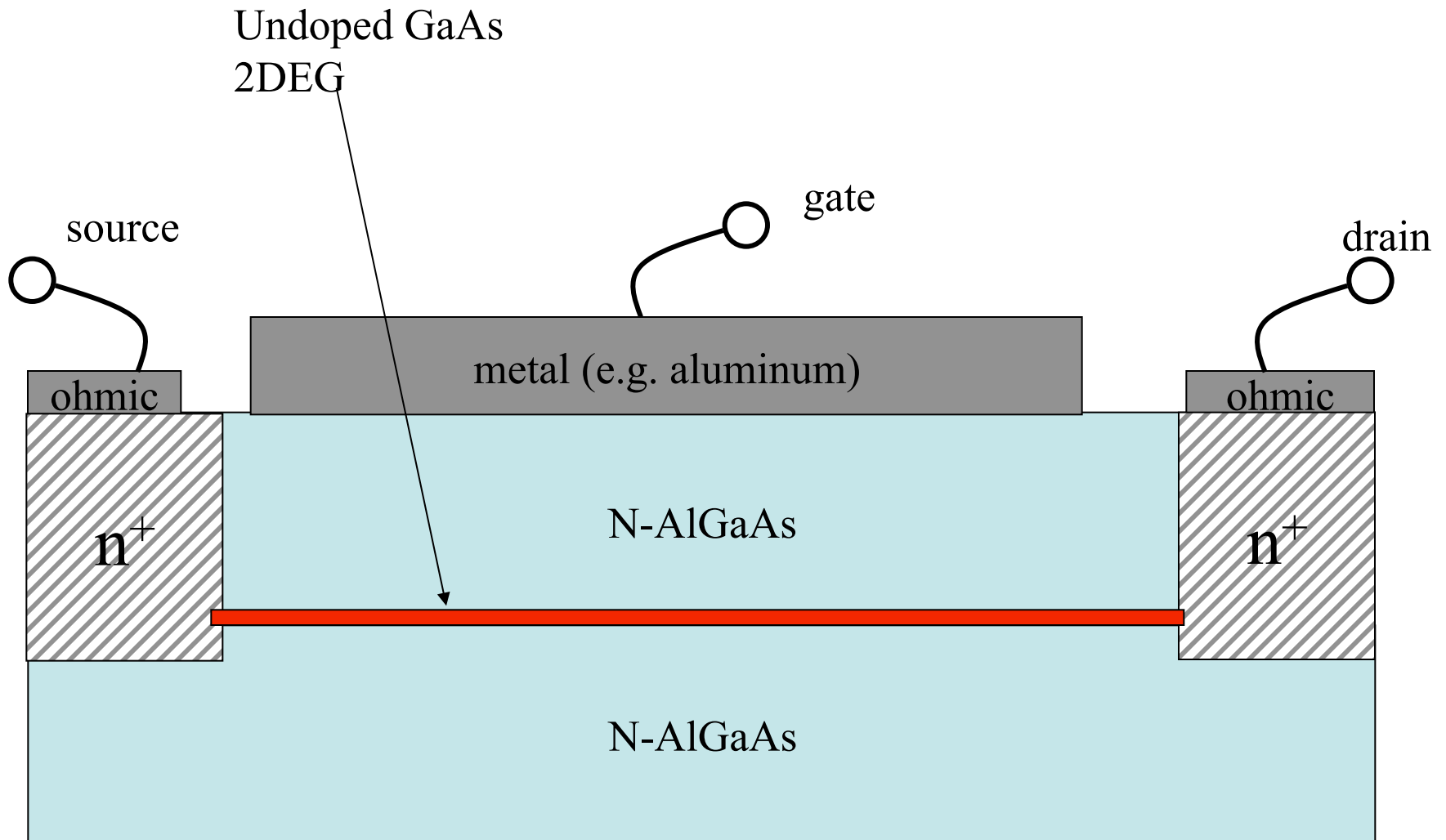

# 2DEG

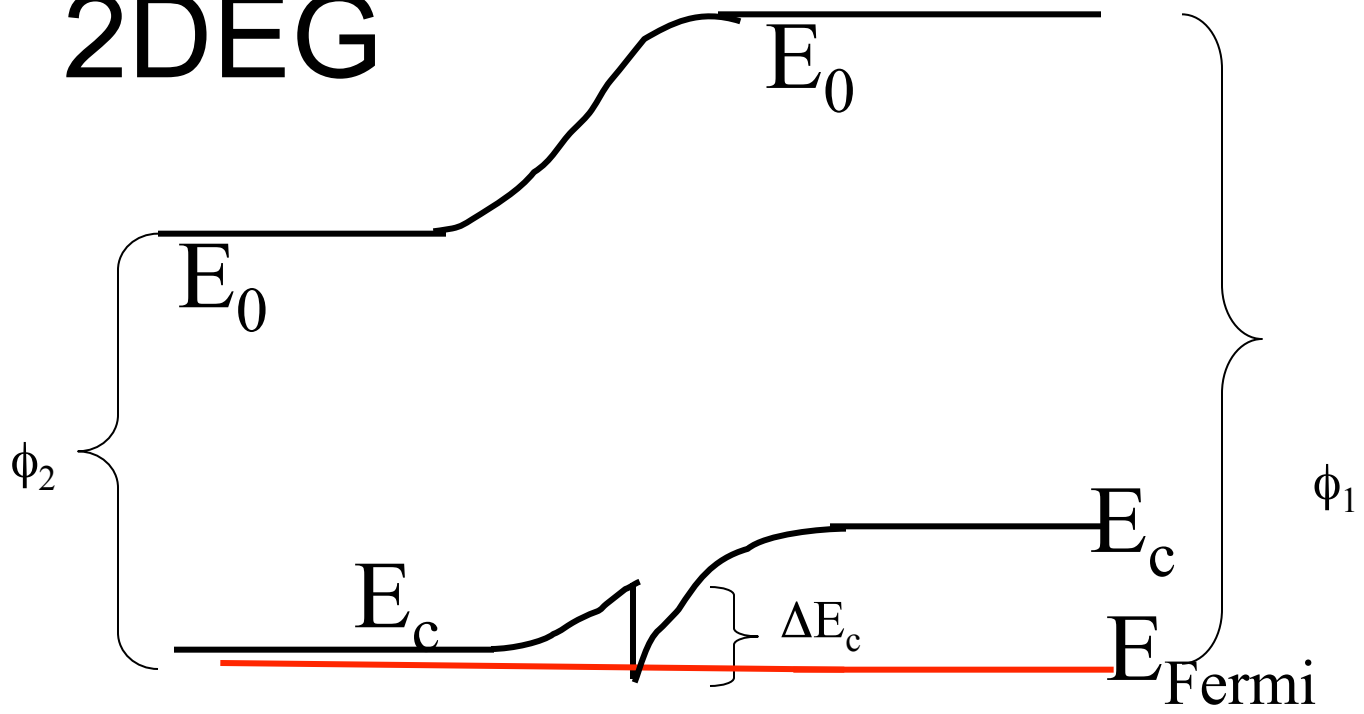

$E_{\text{Fermi}}$

GaAs

AlGaAs

$E_v$

$E_v$

$\Delta E_v$

# FET I-V curves



# MESFET:

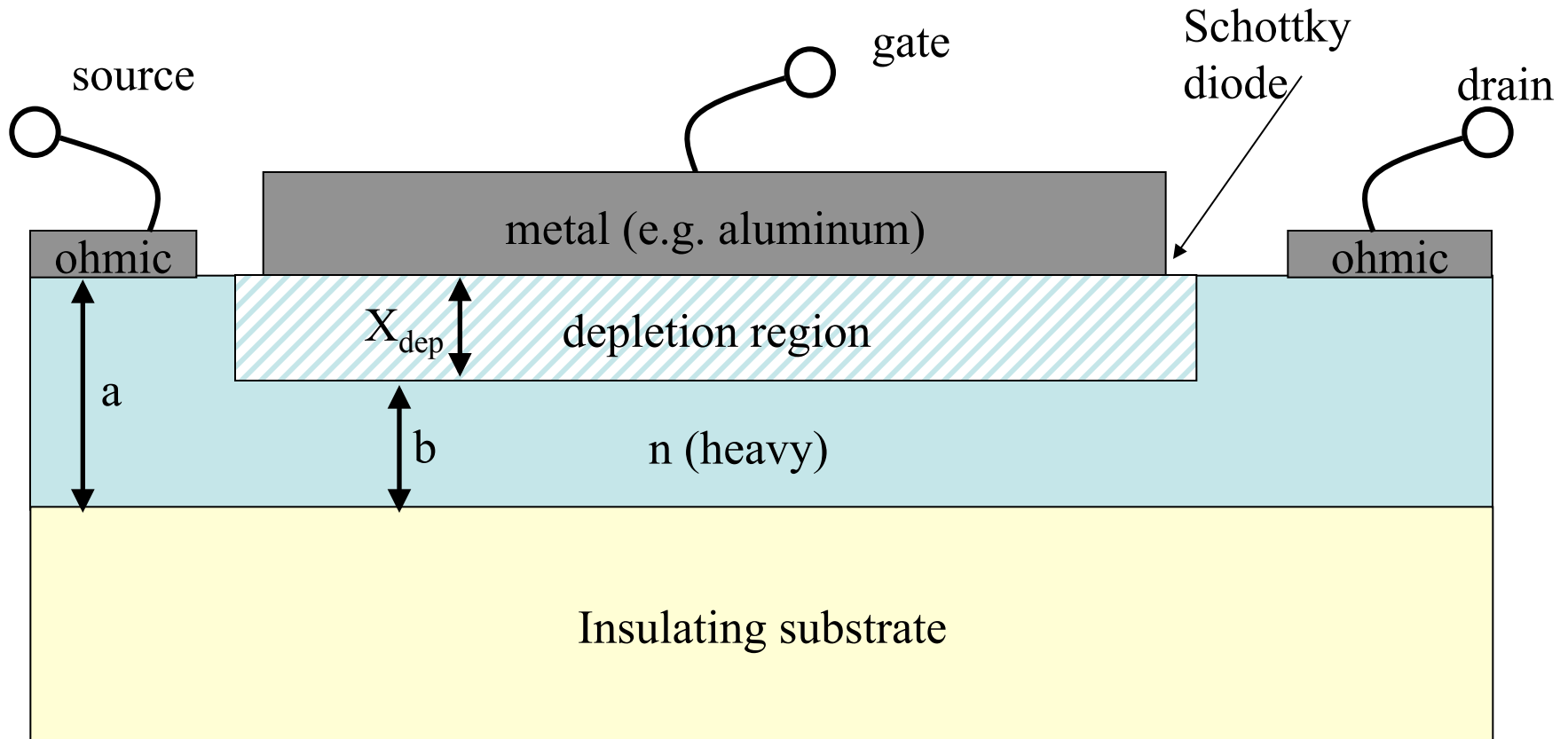

$$X_{dep} = \sqrt{\frac{2\epsilon}{eN_d} (\phi_{bi} - V_a)}$$

# Goal:

Calculate  $I_{sd}$  vs.  $V_{sd}$

Need to know shape of channel potential (not line)

# MESFET:

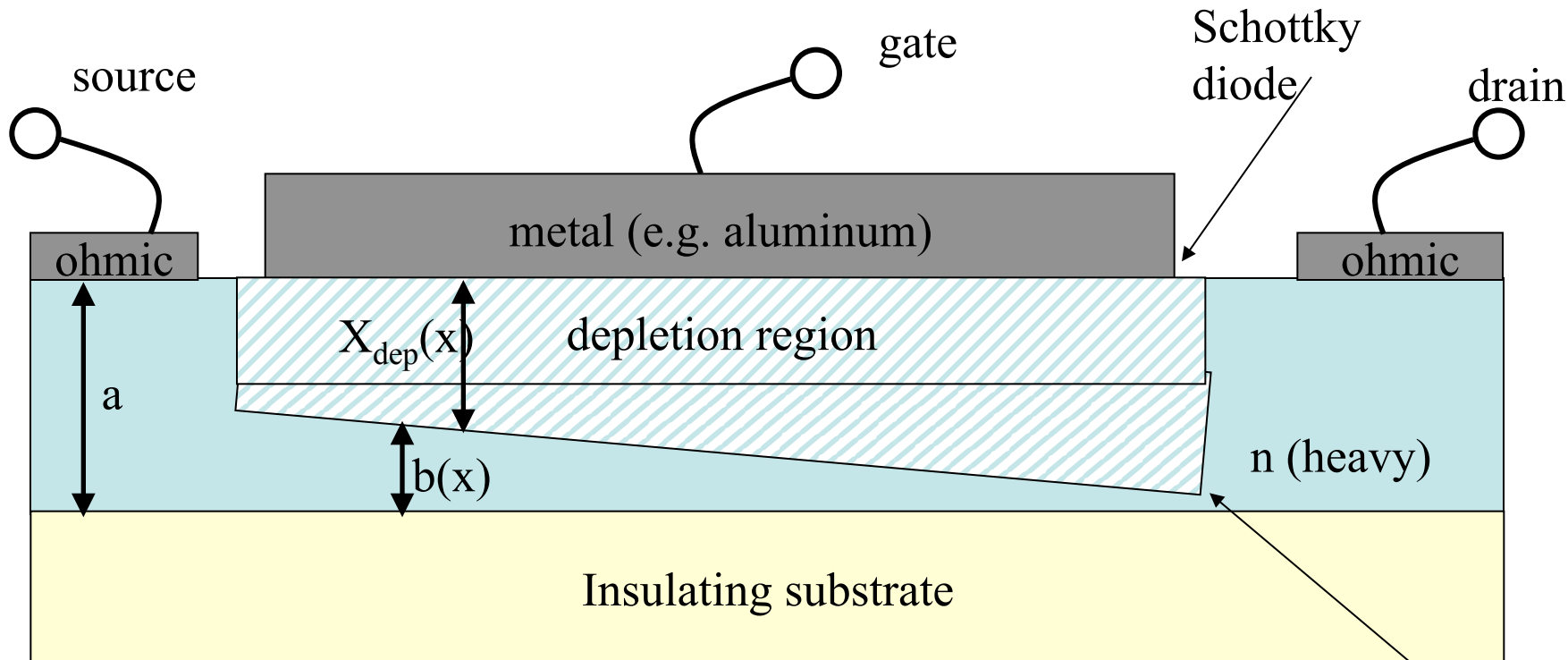

$$X_{dep} = \sqrt{\frac{2\epsilon}{eN_d} (\phi_{bi} - V_{GS} - V_{CS}(x))}$$

$$V_{CS}(x) = 0 @ x = 0$$

$$V_{CS}(x) = V_{SD} @ x = L$$

When they touch, define  $V_{DS,sat}$

$$J = e \cdot \mu \cdot n \cdot E$$

$$I_D = J \cdot (area) = e \cdot \mu \cdot n(x) \cdot E(x) \cdot W \cdot b(x)$$

# MESFET:

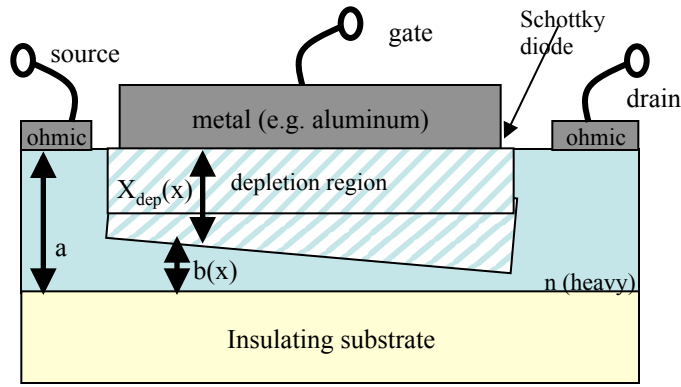

$$I_D = e \cdot \mu \cdot n(x) \cdot E(x) \cdot W \cdot b(x)$$

$$X_{dep} = \sqrt{\frac{2\epsilon}{eN_d} \underbrace{(\phi_{bi} - V_{GS} - V_{CS}(x))}_{\phi_s(x)}}$$

$$E(x) = -\frac{\partial \phi_s(x)}{\partial x}$$

$$i_{ch} = e \cdot \mu \cdot N_d \cdot a \cdot W \cdot \left(1 - \sqrt{\frac{\phi_s(x)}{\phi_{00}}}\right) \cdot \left(-\frac{\partial \phi_s(x)}{\partial x}\right)$$

$$\phi_{00} \equiv \frac{eN_d}{2\epsilon} a^2$$

We know  $\phi(x)$  at both ends, but need to know full function to get  $d\phi/dx$  for  $i_{ch}$ .

$$\frac{\partial i_{ch}}{\partial x} = 0$$

(Current is conserved.)

$$\int_x^L i_{ch} dx' = \int_x^L e \cdot \mu \cdot N_d \cdot a \cdot W \cdot \left(1 - \sqrt{\frac{\phi_s(x')}{\phi_{00}}}\right) \cdot \left(-\frac{\partial \phi_s(x')}{\partial x'}\right) dx'$$

# MESFET:

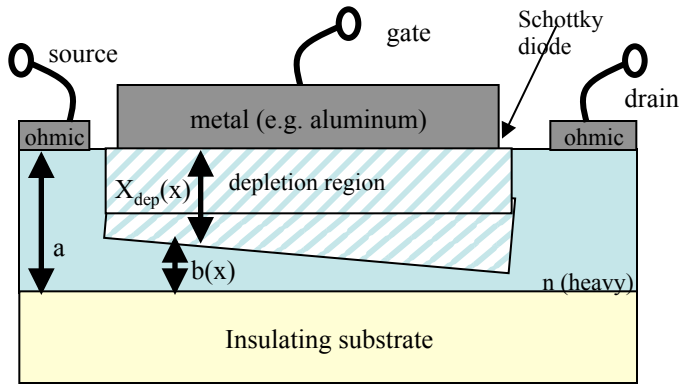

$$\phi_s(x) \equiv \phi_{bi} - V_{GS} - V_{CS}(x)$$

$$V_{CS}(x) = 0 @ x = 0$$

$$V_{CS}(x) = V_{SD} @ x = L$$

$$\int_x^L i_{ch} dx' = \int_x^L e \cdot \mu \cdot N_d \cdot a \cdot W \cdot \left(1 - \sqrt{\frac{\phi_s(x')}{\phi_{00}}}\right) \cdot \left(-\frac{\partial \phi_s(x')}{\partial x'}\right) dx'$$

$$LHS = I_D(L - x)$$

$$RHS = \int_{\phi_s(x)}^{\phi_s(L)} e \cdot \mu \cdot N_d \cdot a \cdot W \cdot \left(1 - \sqrt{\frac{\phi_s(x')}{\phi_{00}}}\right) \cdot \left(-\frac{\partial \phi_s(x')}{\partial x'}\right)$$

$$= e \cdot \mu \cdot N_d \cdot a \cdot W \cdot \left[ \phi_s(L) - \phi_s(x) - \frac{2}{3} \left(\frac{\phi_s(0)}{\phi_{00}}\right)^{3/2} + \frac{2}{3} \left(\frac{\phi_s(x)}{\phi_{00}}\right)^{3/2} \right]$$

$$\Rightarrow I_D = \frac{1}{L - x} e \cdot \mu \cdot N_d \cdot a \cdot W \cdot \left[ \phi_s(L) - \phi_s(x) - \frac{2}{3} \left(\frac{\phi_s(0)}{\phi_{00}}\right)^{3/2} + \frac{2}{3} \left(\frac{\phi_s(x)}{\phi_{00}}\right)^{3/2} \right]$$

# MESFET:

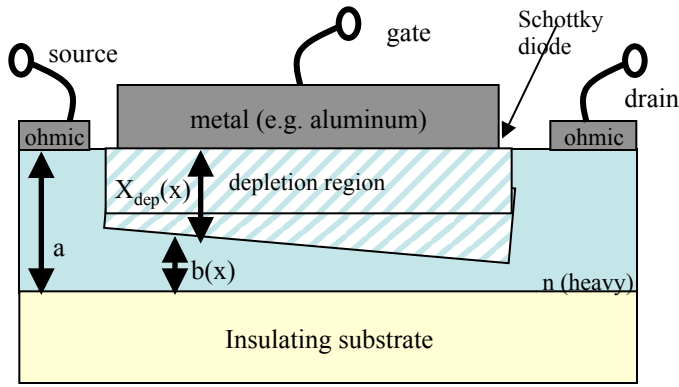

$$\phi_s(x) \equiv \phi_{bi} - V_{GS} - V_{CS}(x)$$

If

$$V_{CS}(x) > V_{SD,Sat}$$

then

$$\phi_s(x) \equiv \phi_{bi} - V_{GS} - V_{SD,sat}$$

$$V_{CS}(x) = 0 @ x = 0$$

$$V_{CS}(x) = V_{SD} @ x = L$$

$$I_D = \frac{1}{L-x} e \cdot \mu \cdot N_d \cdot a \cdot W \cdot \left[ \phi_s(L) - \phi_s(x) - \frac{2}{3} \left( \frac{\phi_s(0)}{\phi_{00}} \right)^{3/2} + \frac{2}{3} \left( \frac{\phi_s(x)}{\phi_{00}} \right)^{3/2} \right]$$

For  $x = 0$ :

$$I_D = \frac{1}{L} e \cdot \mu \cdot N_d \cdot a \cdot W \cdot \left[ \phi_s(L) - \phi_s(0) - \frac{2}{3} \left( \frac{\phi_s(0)}{\phi_{00}} \right)^{3/2} + \frac{2}{3} \left( \frac{\phi_s(0)}{\phi_{00}} \right)^{3/2} \right]$$

This is desired  $I_D$  vs  $V_{sd}$ .

Called gradual channel approximation (assumes  $a \ll L$ ).

# Potential profile:

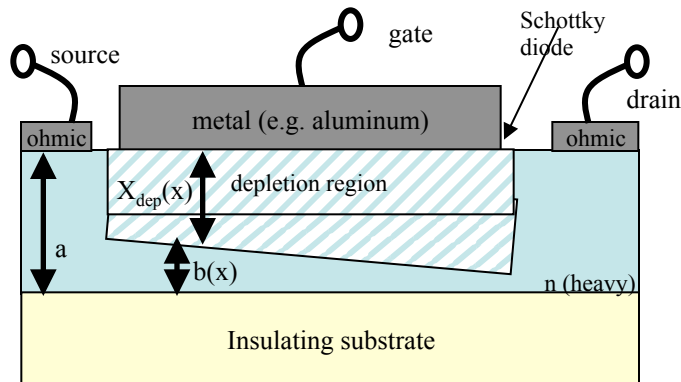

$$\phi_s(x) \equiv \phi_{bi} - V_{GS} - V_{CS}(x)$$

If

$$V_{CS}(x) > V_{SD,Sat}$$

then

$$\phi_s(x) \equiv \phi_{bi} - V_{GS} - V_{SD,sat}$$

$$V_{CS}(x) = 0 @ x = 0$$

$$V_{CS}(x) = V_{SD} @ x = L$$

$$I_D = \frac{1}{L-x} e \cdot \mu \cdot N_d \cdot a \cdot W \cdot \left[ \phi_s(L) - \phi_s(x) - \frac{2}{3} \left( \frac{\phi_s(0)}{\phi_{00}} \right)^{3/2} + \frac{2}{3} \left( \frac{\phi_s(x)}{\phi_{00}} \right)^{3/2} \right]$$

For  $x = 0$ :

$$I_D = \frac{1}{L} e \cdot \mu \cdot N_d \cdot a \cdot W \cdot \left[ \phi_s(L) - \phi_s(0) - \frac{2}{3} \left( \frac{\phi_s(0)}{\phi_{00}} \right)^{3/2} + \frac{2}{3} \left( \frac{\phi_s(0)}{\phi_{00}} \right)^{3/2} \right]$$

So:

$$\phi_s(x) - \phi_s(0) - \frac{2}{3} \left( \frac{\phi_s(x)}{\phi_{00}} \right)^{3/2} + \frac{2}{3} \left( \frac{\phi_s(0)}{\phi_{00}} \right)^{3/2} = \frac{x}{L} \left( \phi_s(L) - \phi_s(0) - \frac{2}{3} \left( \frac{\phi_s(L)}{\phi_{00}} \right)^{3/2} + \frac{2}{3} \left( \frac{\phi_s(0)}{\phi_{00}} \right)^{3/2} \right)$$

This is a transcendental equation for  $\phi_s(x)$

# Velocity saturation

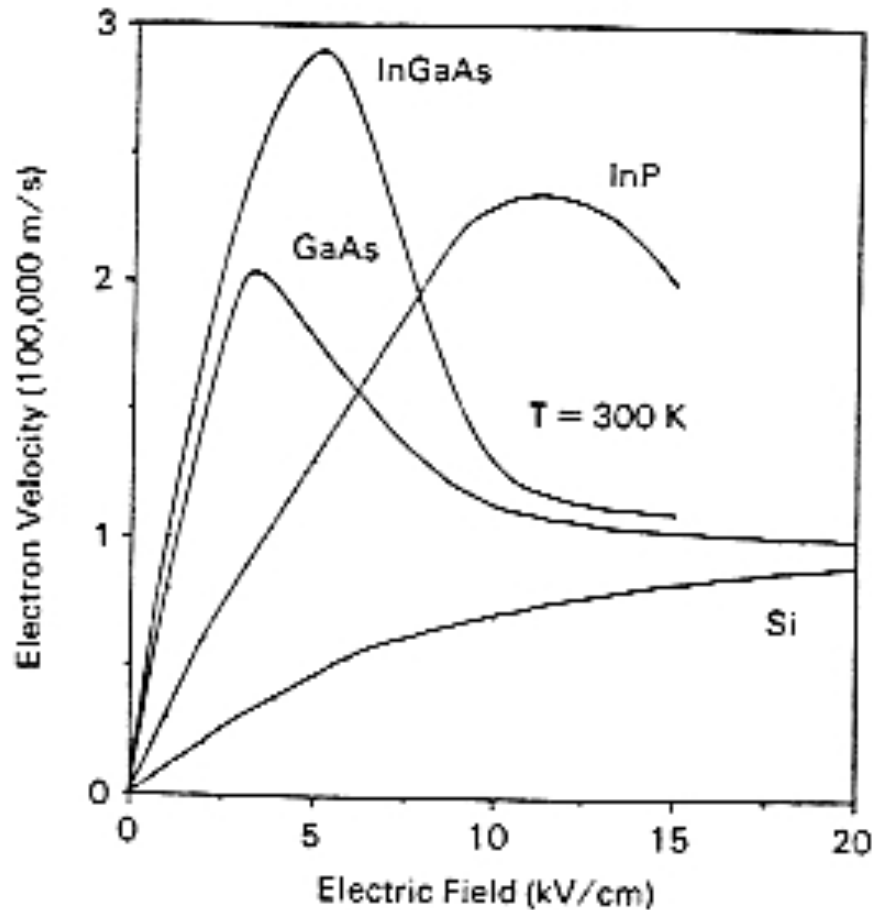

$$v = \mu \cdot E$$

$$\rightarrow v_{sat}$$

From Shur, Physics of Semiconductor Devices



# Velocity saturation:

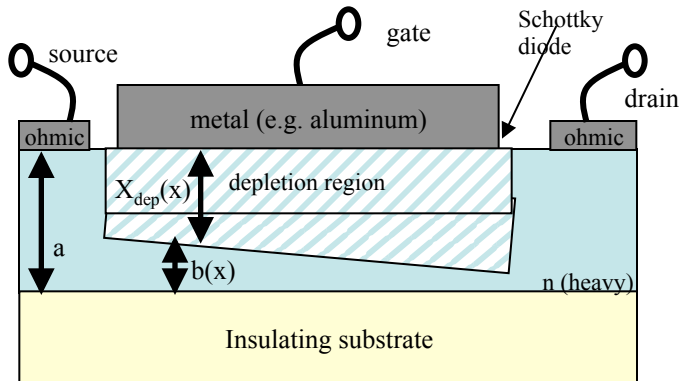

$$J = e \cdot \mu \cdot n \cdot E$$

Not true for short channels (discuss on board).

$$J = e \cdot n \cdot v_{sat}$$

Independent of E.

Need to recalculate IV curve. Model as linear and saturated velocity regions.

Also, model as two-region velocity-field curve.

I-V curve is similar to long-channel FET qualitatively.