

Lecture 4: Heterojunction Bipolar Transistors (HBTs)

Bipolar means both electrons,
holes participate in the device.
(In contrast, FET is unipolar.)

Outline for today

- n-p-n homojunction band diagrams
- n-p-n DC I-V curves, etc.
- DC circuit models
- Why are we doing this? YOU, the designer will need to know how different transistor geometries translate into different effective circuit elements.

n-p-n geometry

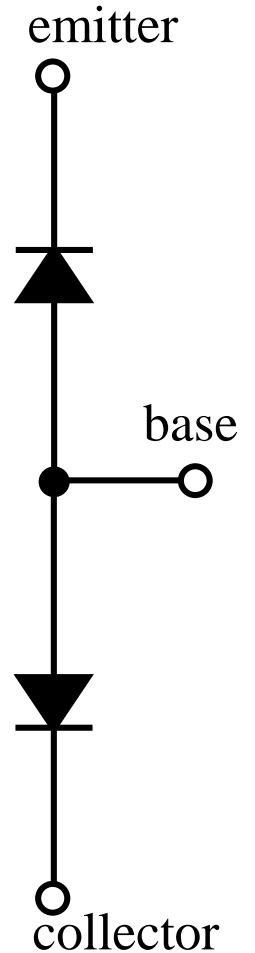
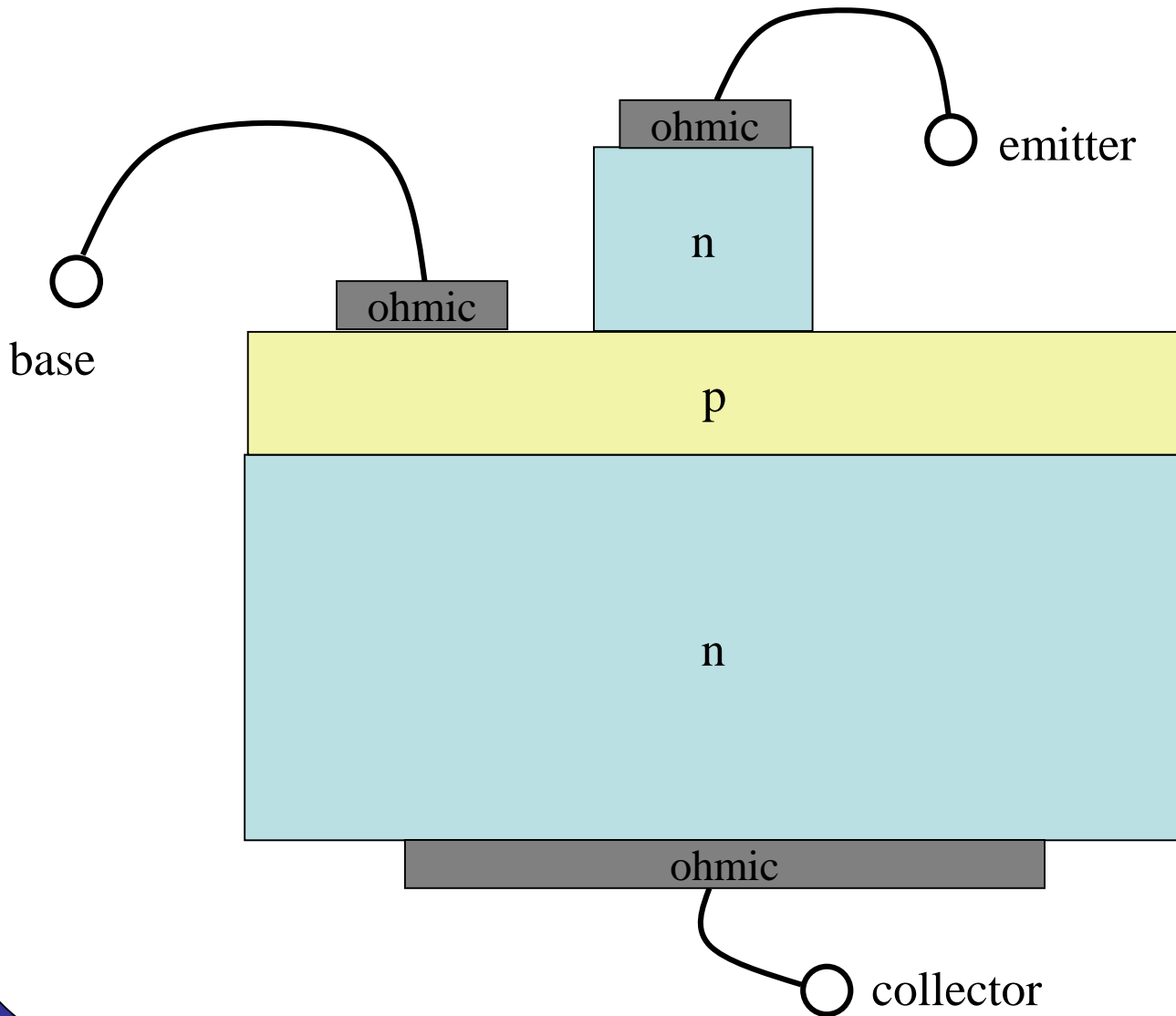

circuit only
if base LONG

n-p-n junction at zero bias

n

p

n

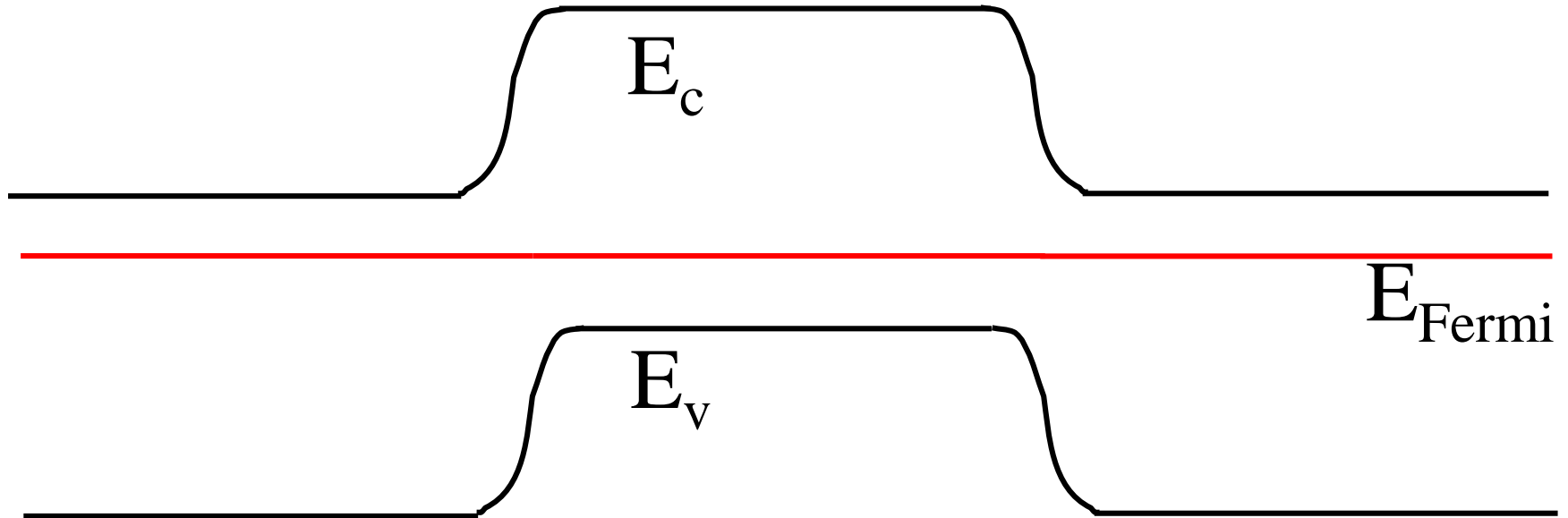

Bias conditions

Mode	E-B	C-B
Normal active	forward	reverse
saturation	forward	forward
cutoff	reverse	reverse

“Normal active” bias

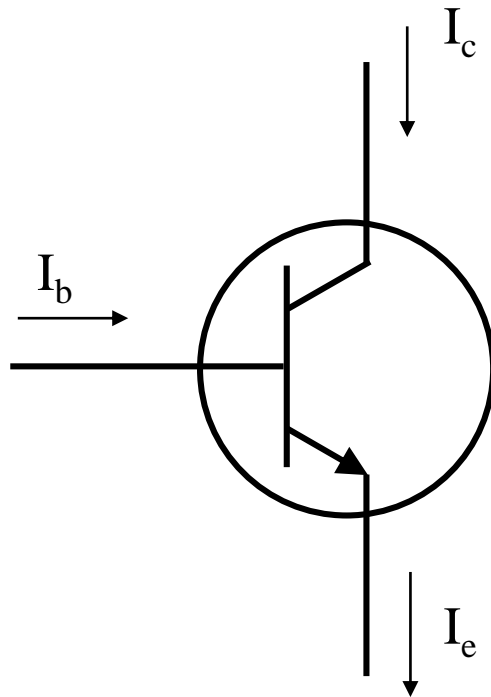

- E-B forward bias ($V_b > V_e$)
- C-B reverse bias ($V_c > V_b$)
- $I_{ce} = 100 I_{be} = \beta I_{be}$

All of chapter 3 is about calculating β .

Many current components

- Electron drift E-B
- Electron diffusion E-B
- Hole drift E-B
- Hole diffusion E-B
- Electron drift C-B
- Electron diffusion C-B
- Hole drift C-B
- Hole diffusion C-B

concentrate on these components, since they are the largest (Discuss why others small.)

“Normal active” band diagram

Emitter

Base

Collector

electrons

electrons

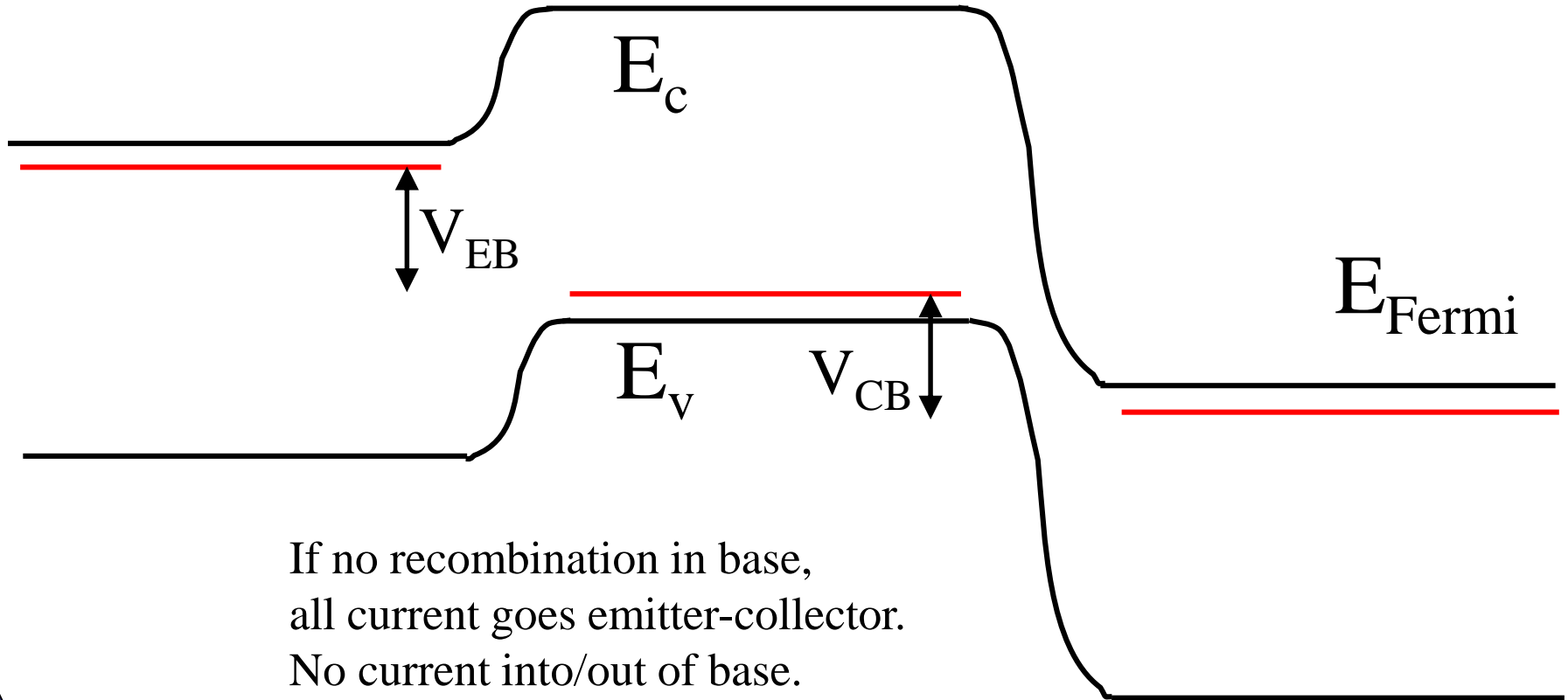

If no recombination in base,
all current goes emitter-collector.
No current into/out of base.

“Normal active” band diagram

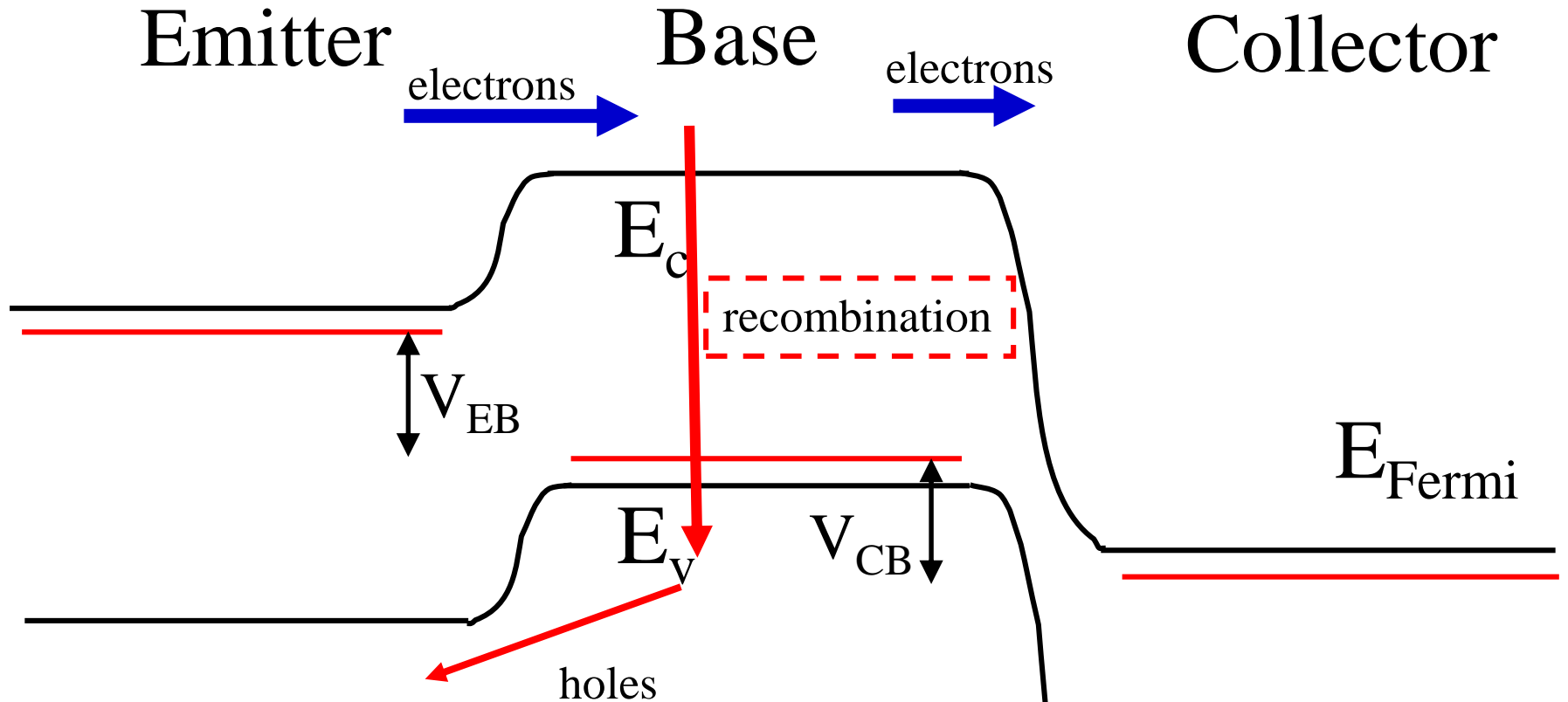

- What fraction of electrons makes it, and what fraction recombines?
- Want $W < L_n$ (diffusion length)
- Holes from B-E cause base current.

“Normal active” schematic

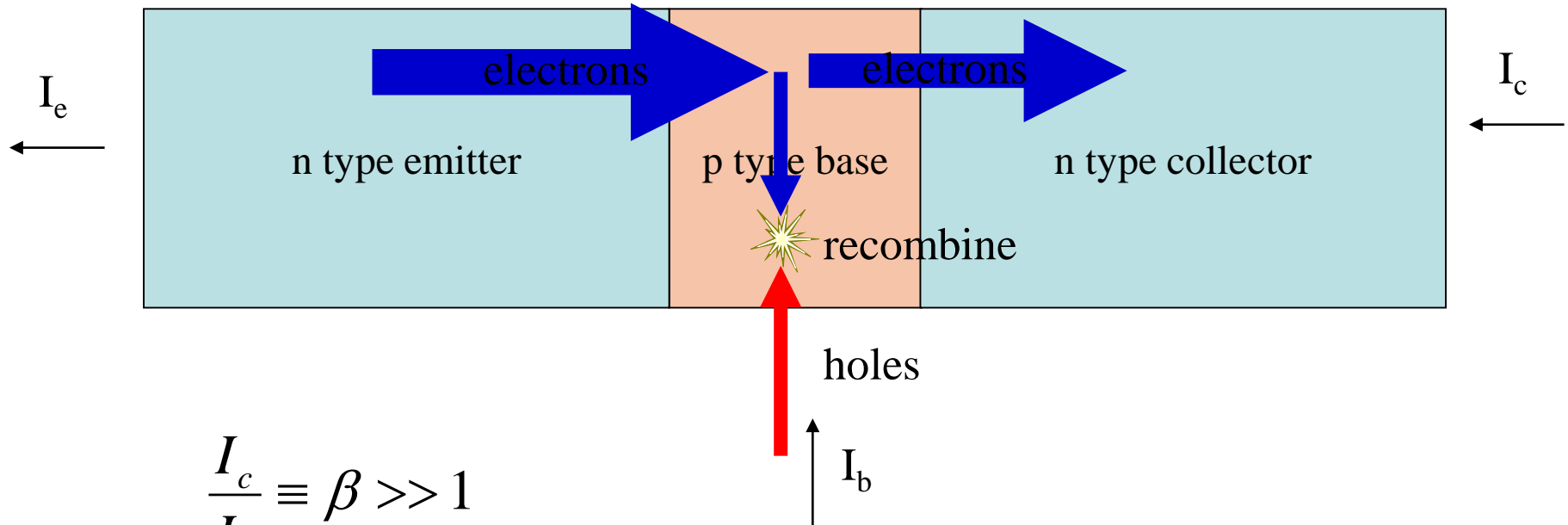

$$\frac{I_c}{I_b} \equiv \beta \gg 1$$

$$\frac{I_c}{I_b} \approx \frac{\tau_n}{\tau_t}$$

$\tau_t \equiv$ transit time (discuss drunken man analogy)

“Normal active” current gain

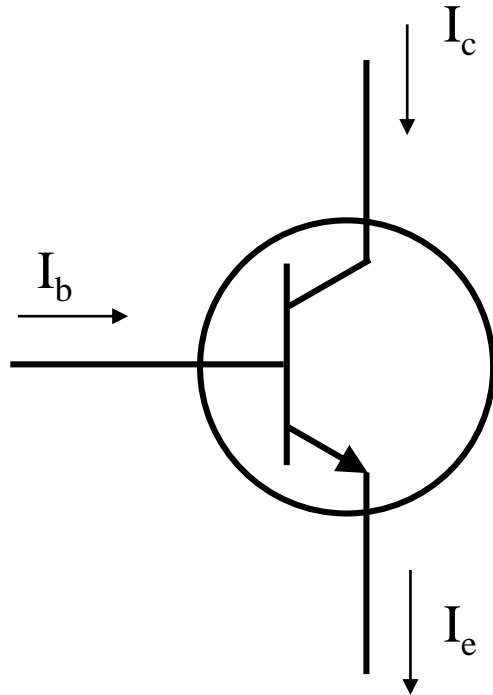

$$\frac{I_c}{I_b} \equiv \beta \gg 1$$

That is simplest circuit model. It just gets more complicated from here!

“Normal active” schematic

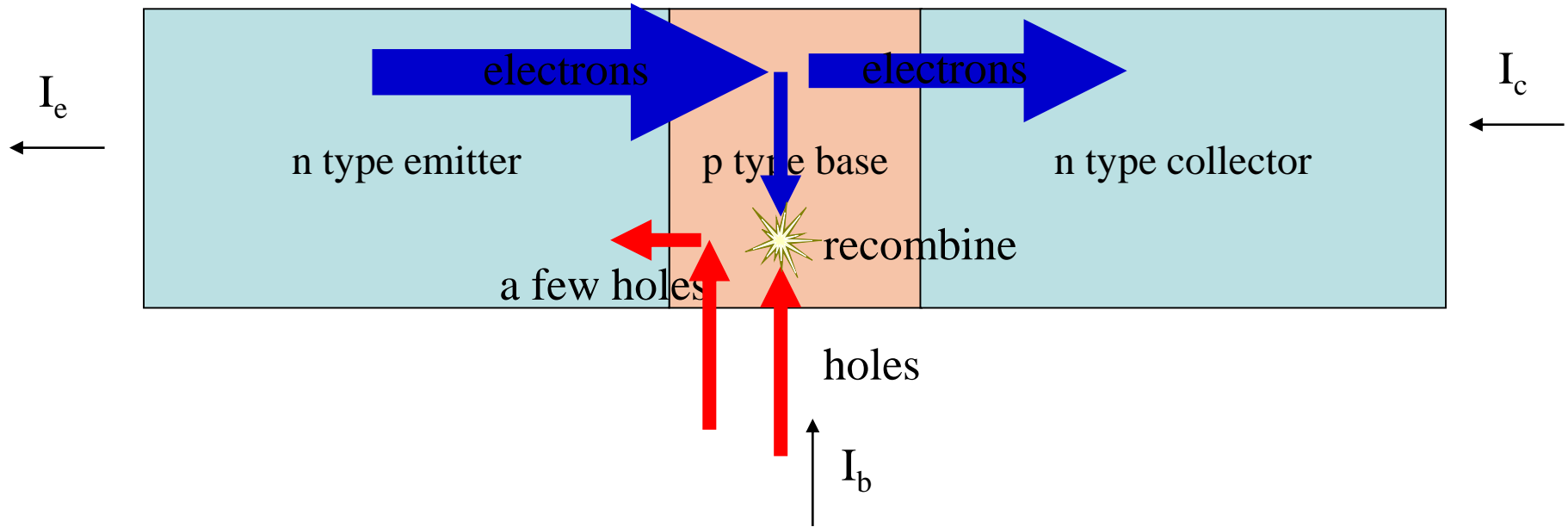

Goal: Find relationship between I_b , I_c

“Normal active” schematic

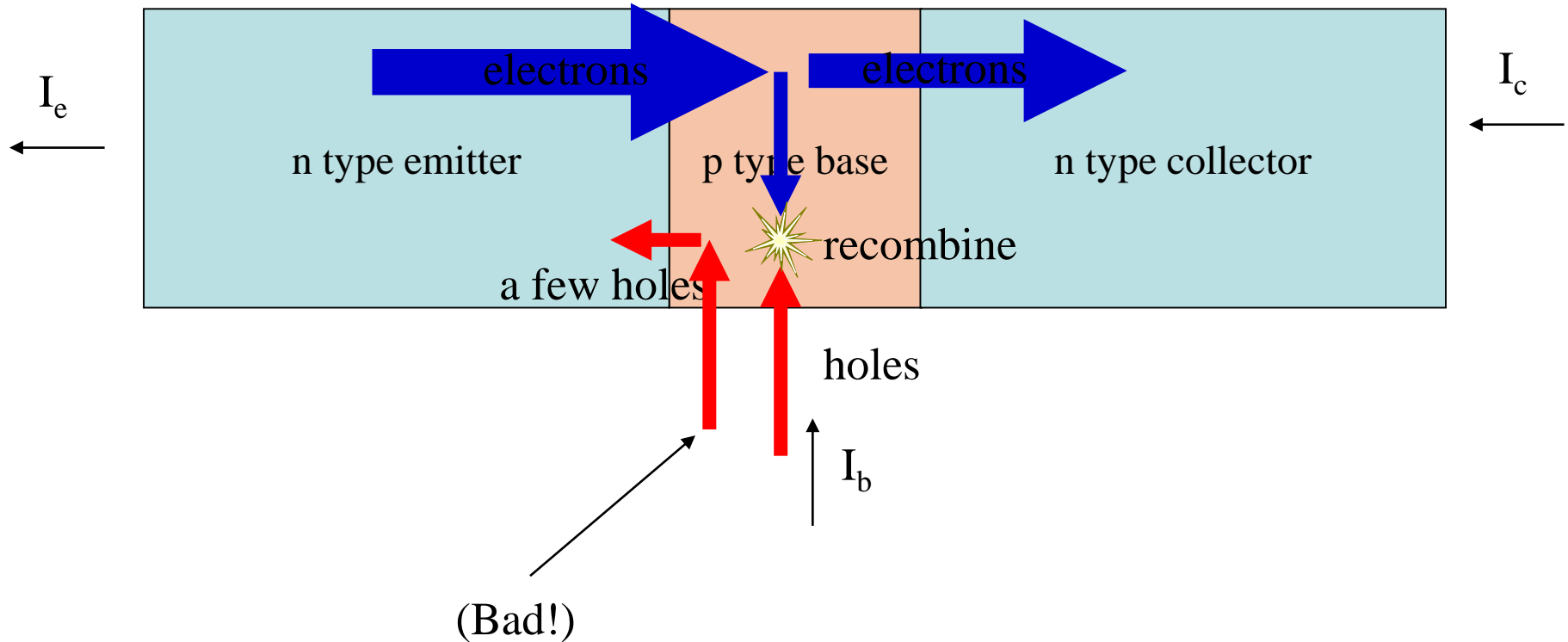

- Want low p-type doping.
- Can show need $n > p$
- But $n > p$ bad for base resistance (speed)
- Solution later: heterojunctions block p injection into emitter
- HBTs can have $p > n$ good for speed

“Normal active” schematic

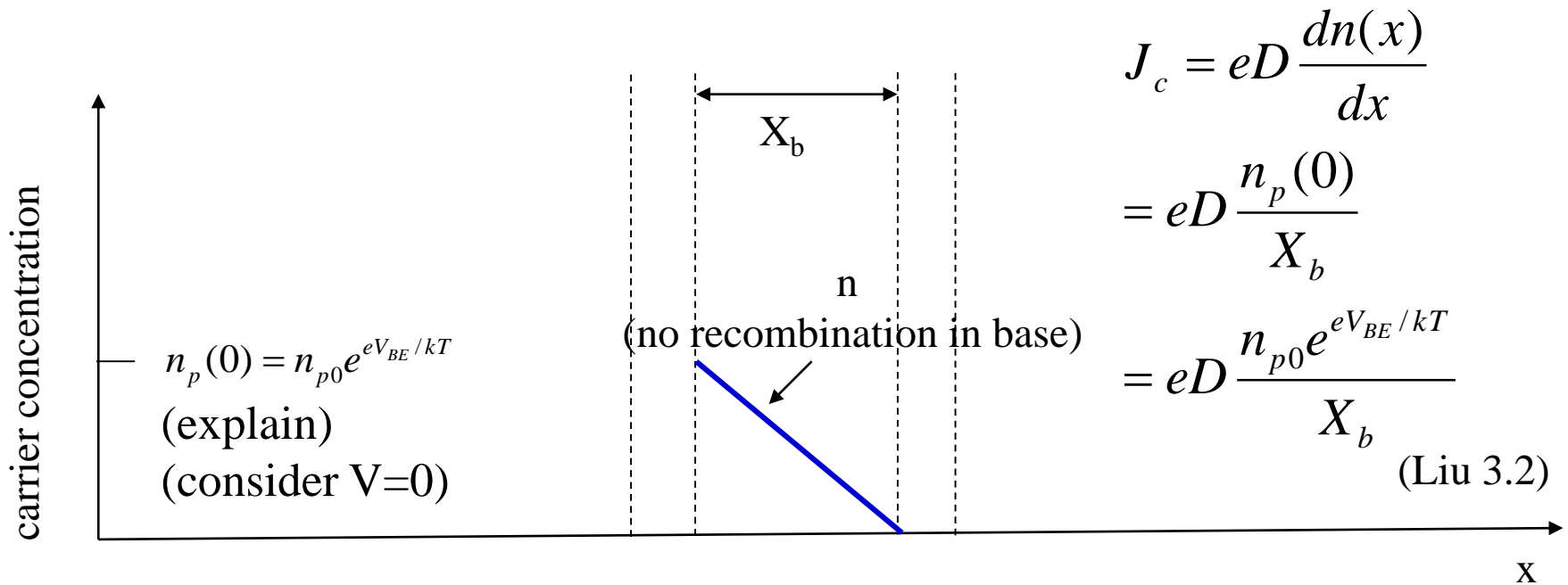
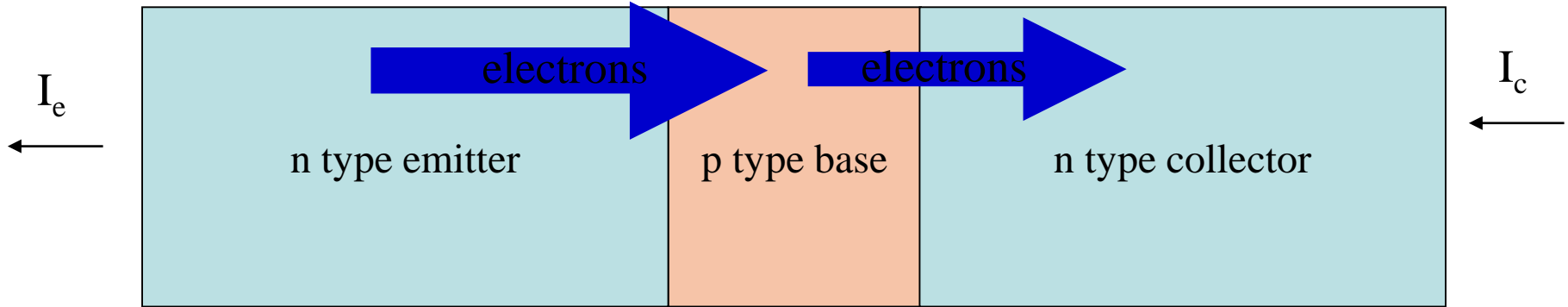

Discuss J vs. I . Discuss line vs. tanh.

“Normal active” schematic

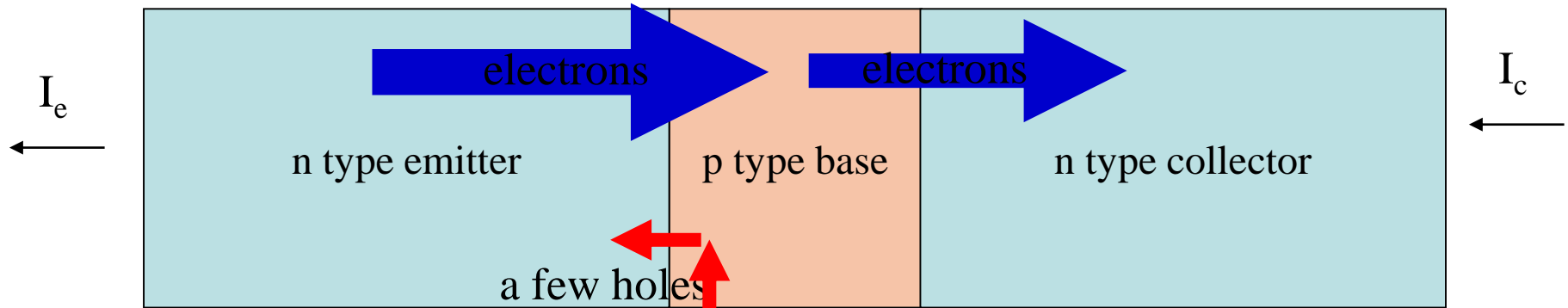

$$J_{B_p} = eD \frac{p_{n0} e^{eV_{BE}/kT}}{L_p}$$

(explain like HW#1)

Liu equation 3.1

“Normal active” schematic

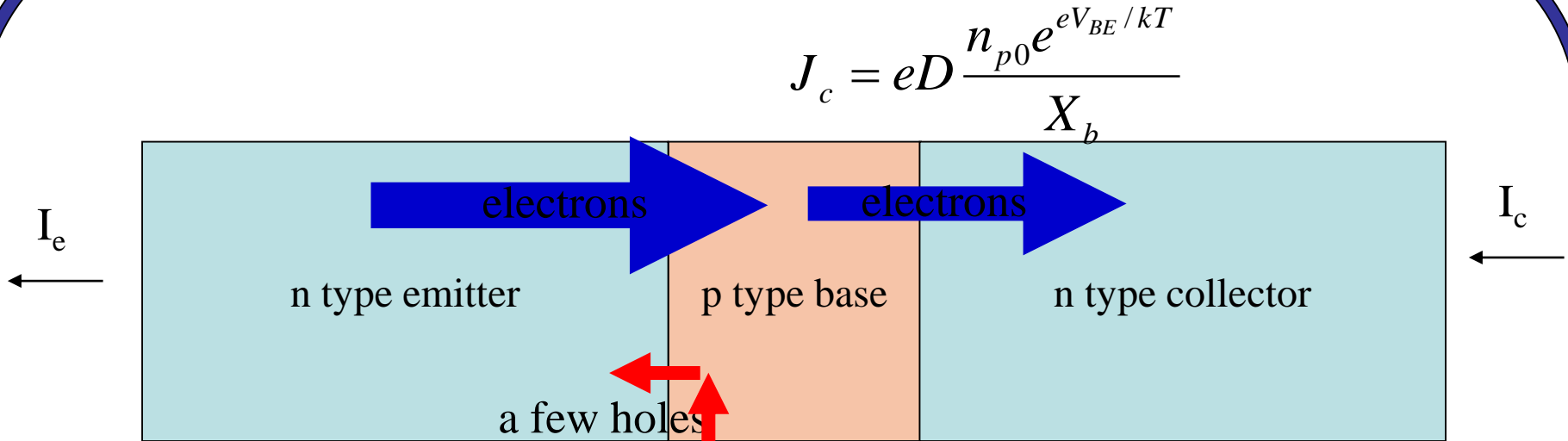

$$J_c = eD \frac{n_{p0} e^{eV_{BE}/kT}}{X_b}$$

$$J_{B_p} = eD \frac{p_{n0} e^{eV_{BE}/kT}}{L_p}$$

$$\frac{I_c}{I_b} \equiv \beta = \frac{eD \frac{n_{p0} e^{eV_{BE}/kT}}{X_b}}{eD \frac{p_{n0} e^{eV_{BE}/kT}}{L_p}} = \frac{n_{p0}}{p_{n0}} \frac{L_p}{X_b} ??? \gg 1$$

Need $n_{p0} \gg p_{n0}$

Bad for base resistance. Bad for E-B capacitance. So bad for speed.

“Normal active” HBT

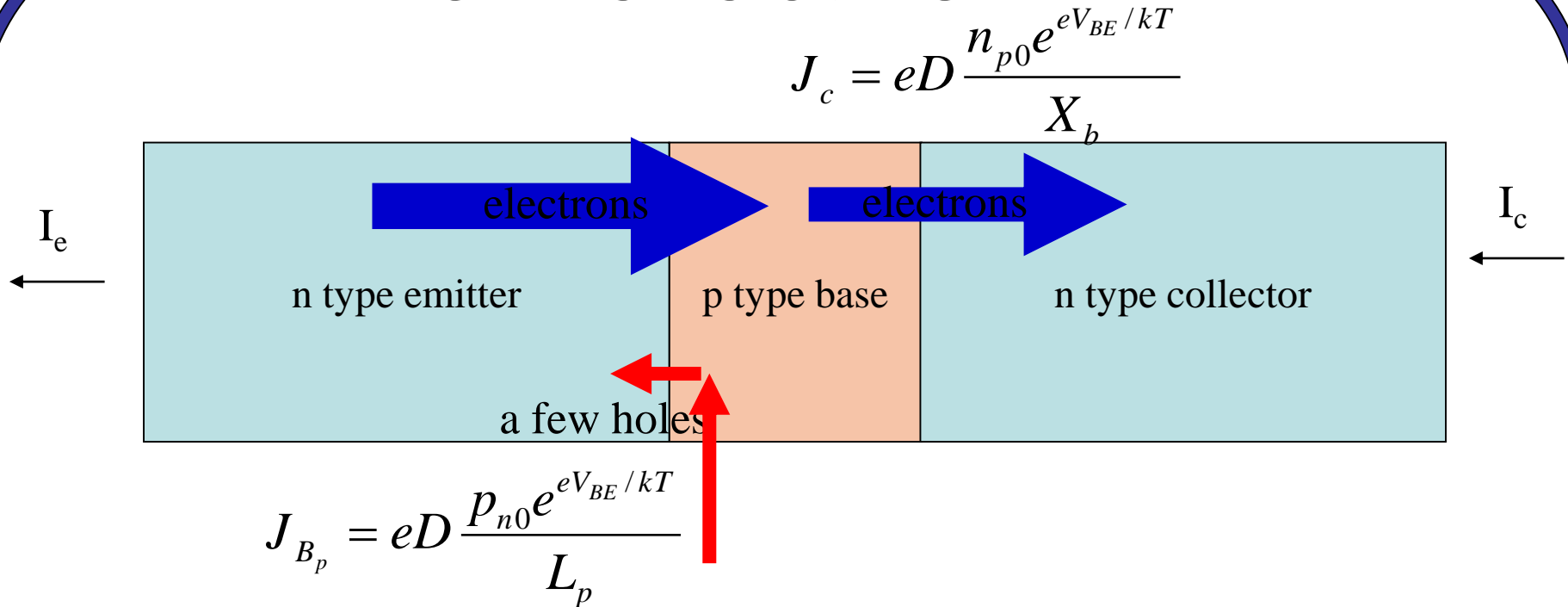

Holes exponentially suppressed if emitter is wider gap. (Graded.)

$$\frac{I_c}{I_b} \equiv \frac{n_{p0}}{p_{n0}} \frac{L_p}{X_b} e^{\Delta E_g / kT} \gg 1$$

Don't need $n_{p0} \gg p_{n0}$

Good for speed. Claims of 1 THz f_T in literature.

“Normal active” schematic

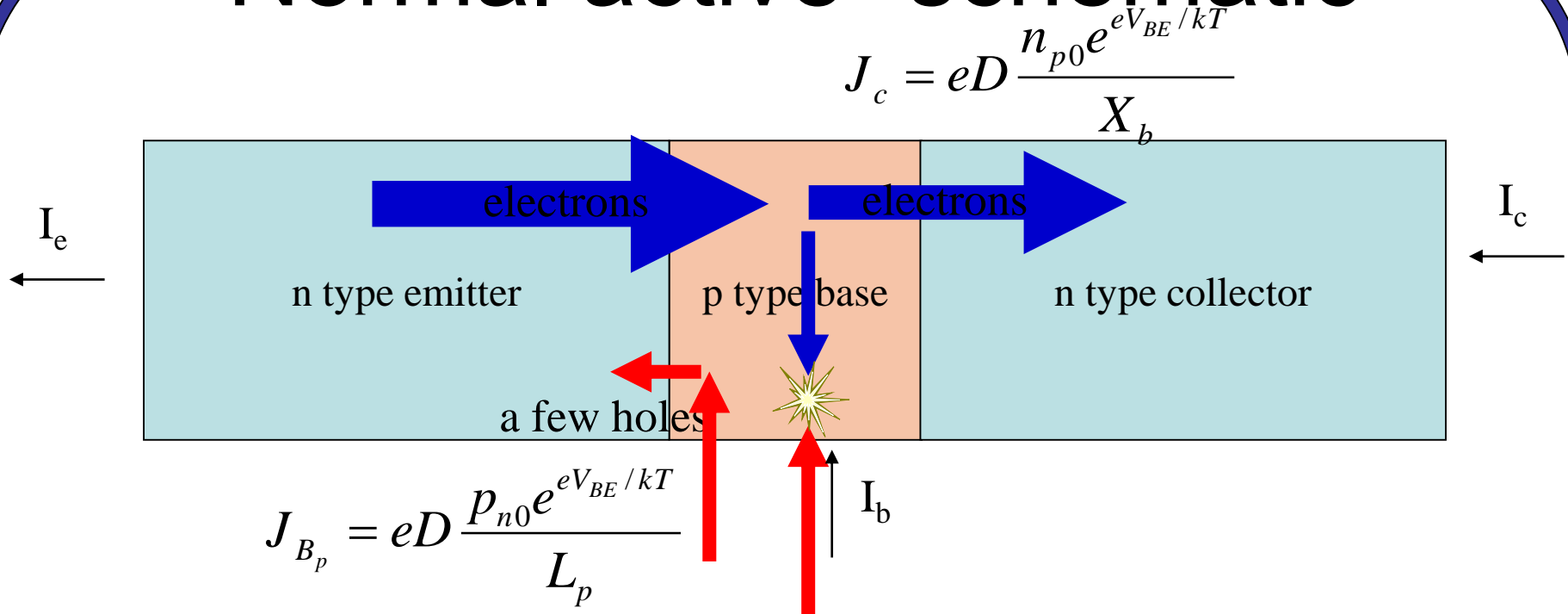

- Depends on recombination processes in:
1. Surface (not contact)
 2. Surface (at base contact)
 3. Bulk
 4. Space charge region



Try to minimize 1,2,4.

“Normal active” schematic

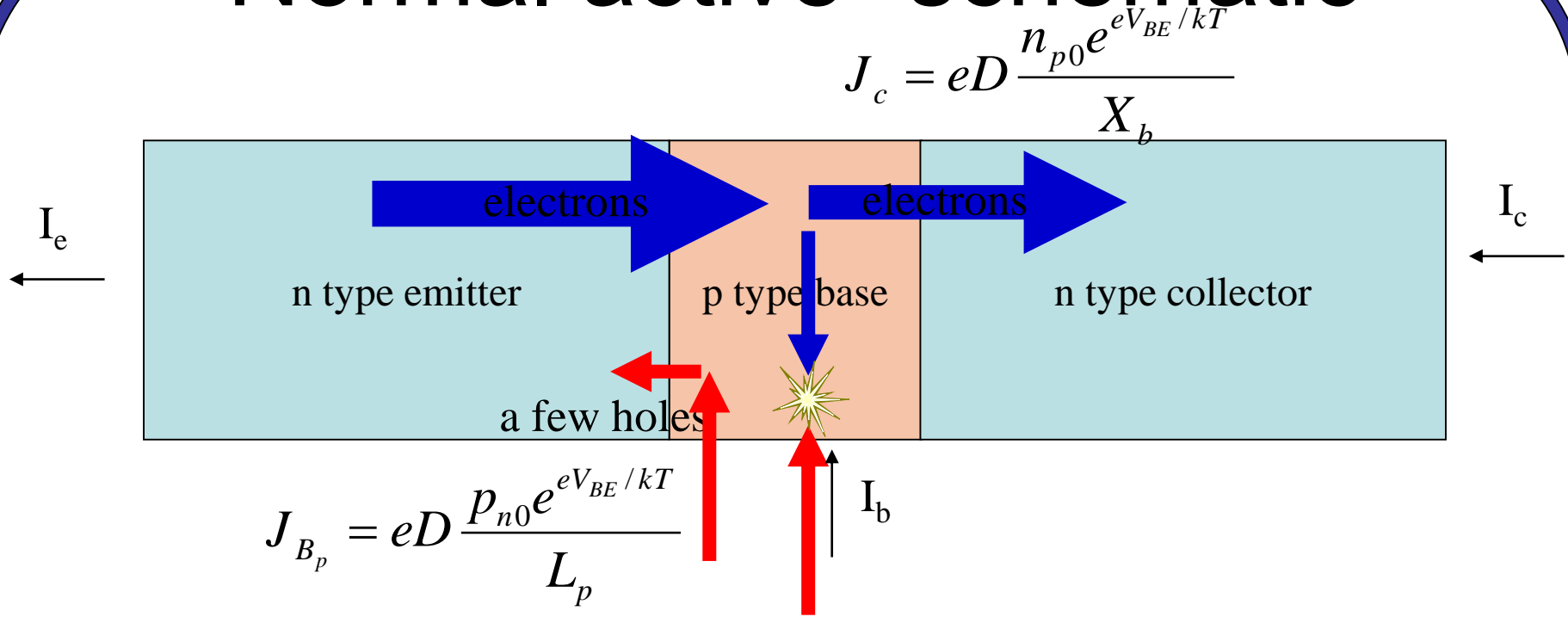

How to calculate:

Don't use line for $n(x)$ but tanh.
 dn/dx em. – dn/dx coll = base curr.
 Explain on board. Will be HW#3.

$$J_{Brec.} = e \frac{W n_{p0} e^{eV_{BE}/kT}}{2\tau_B} = eD \frac{n_{p0} e^{eV_{BE}/kT}}{X_B}$$

“Normal active” schematic

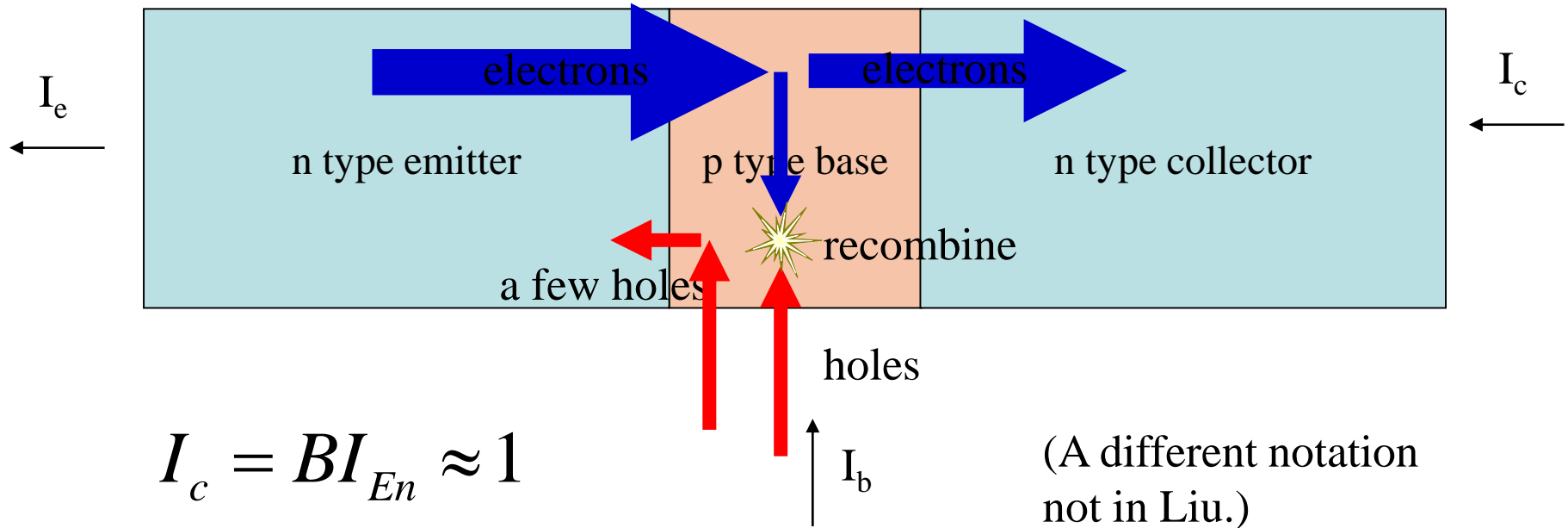

$$I_c = BI_{En} \approx 1$$

$$\gamma \equiv \frac{I_{En}}{I_{Ep} + I_{En}} \approx 1$$

$$\frac{I_c}{I_E} = \frac{I_c}{I_{Ep} + I_{En}} = \frac{BI_{En}}{I_{Ep} + I_{En}} = \gamma B \equiv \alpha \approx 1$$

$$I_b = I_{Ep} + (1 - B)I_{En}$$

$$\frac{I_c}{I_b} = \frac{BI_{En}}{I_{Ep} + (1 - B)I_{En}} = \frac{\alpha}{1 - \alpha} \equiv \beta \gg 1$$

(A different notation not in Liu.)

Complications

- High power
- Spreading resistance

Equivalent circuit 1

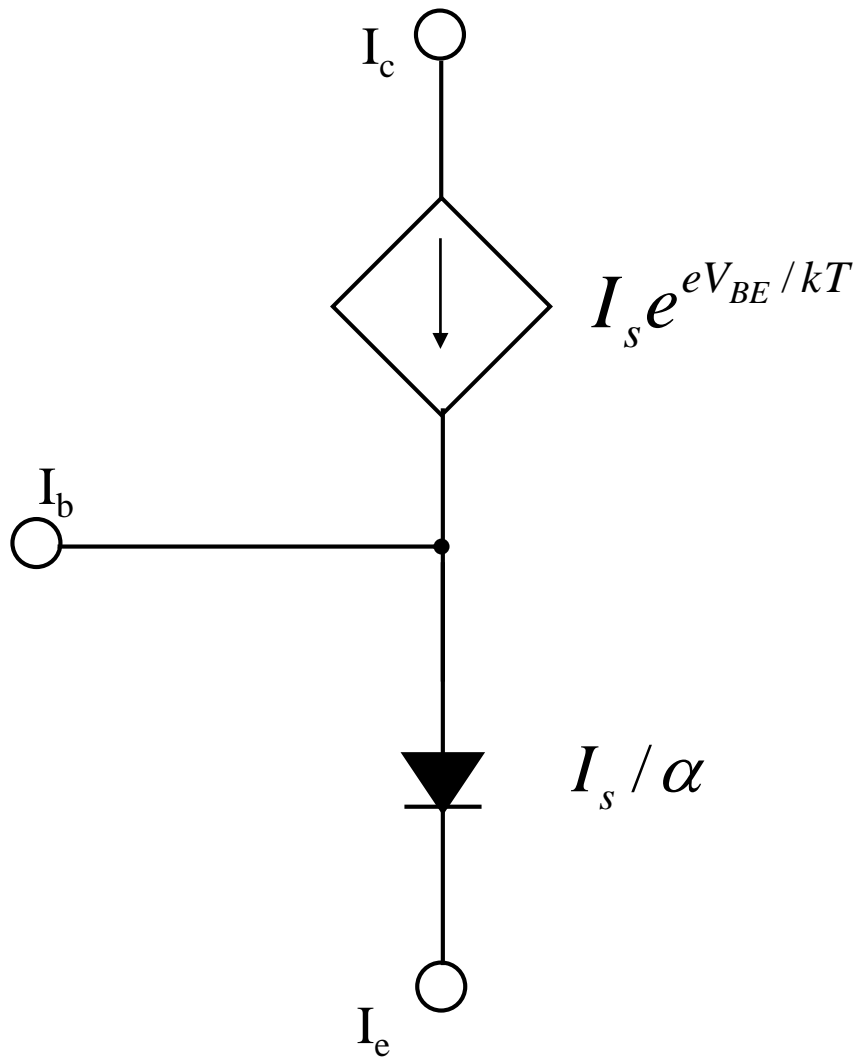

$$I_s \equiv \frac{AeDn_{po}}{X_B}$$

Equivalent circuit 2

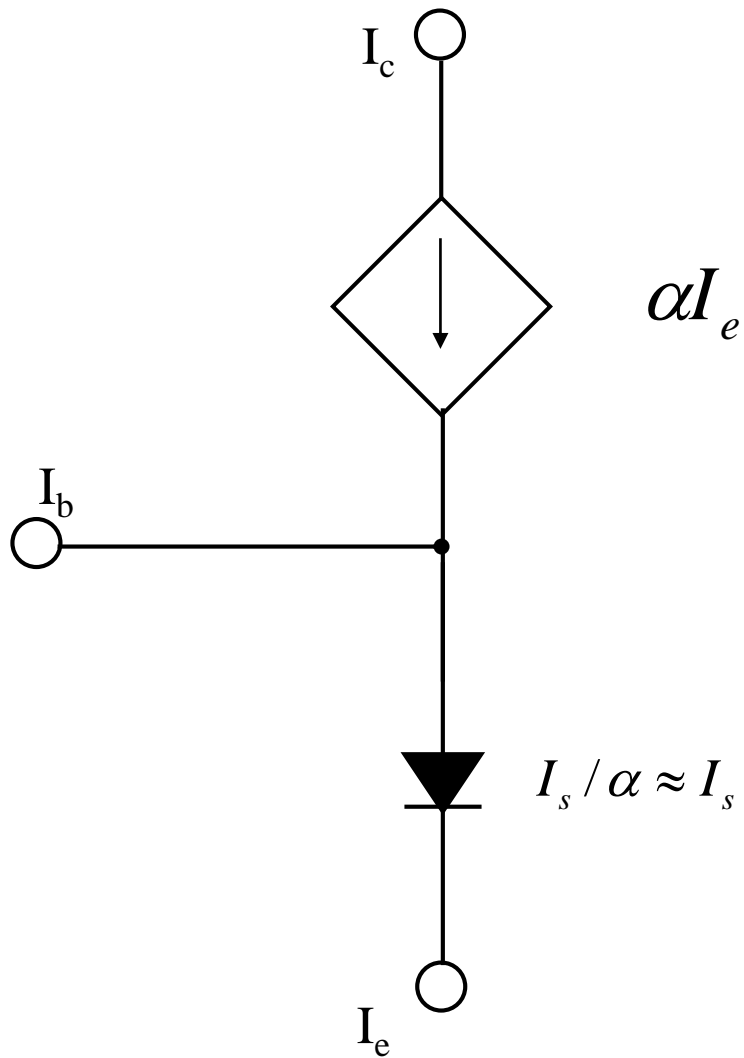

$$I_s \equiv \frac{AeDn_{po}}{X_B}$$

Equivalent circuit 3

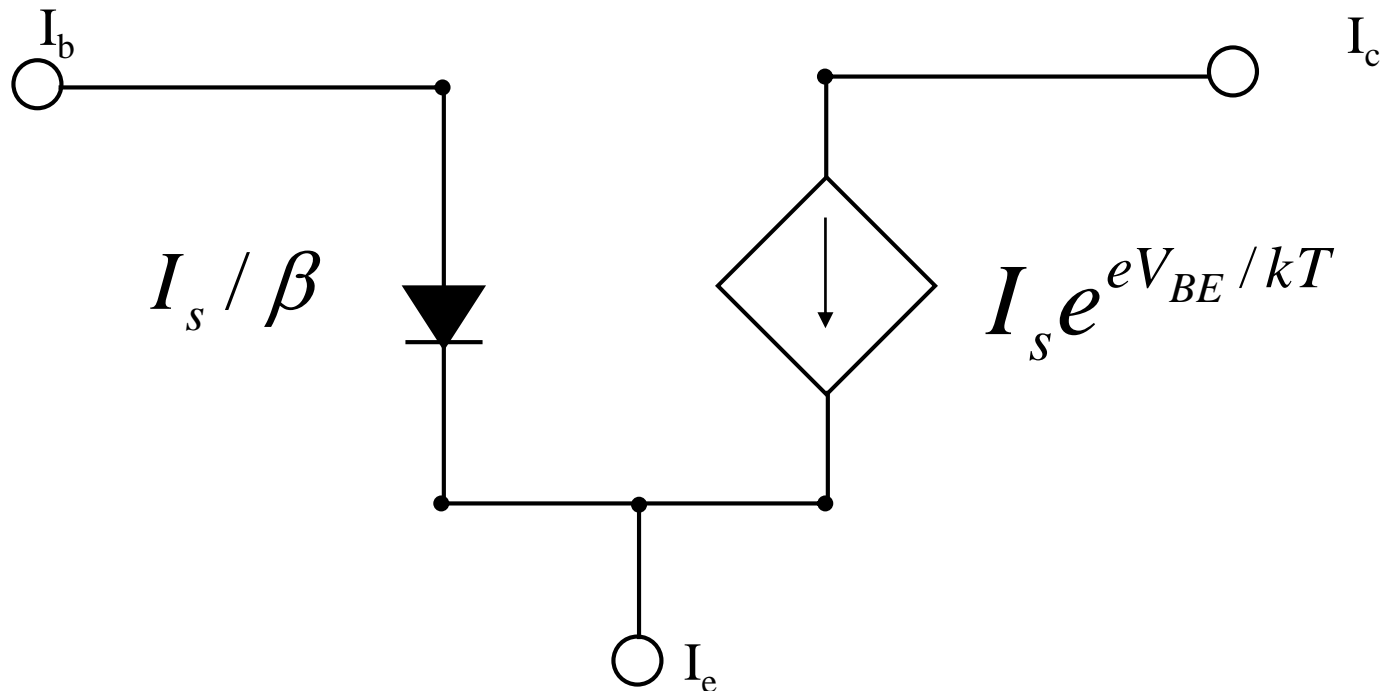

Equivalent circuit 4

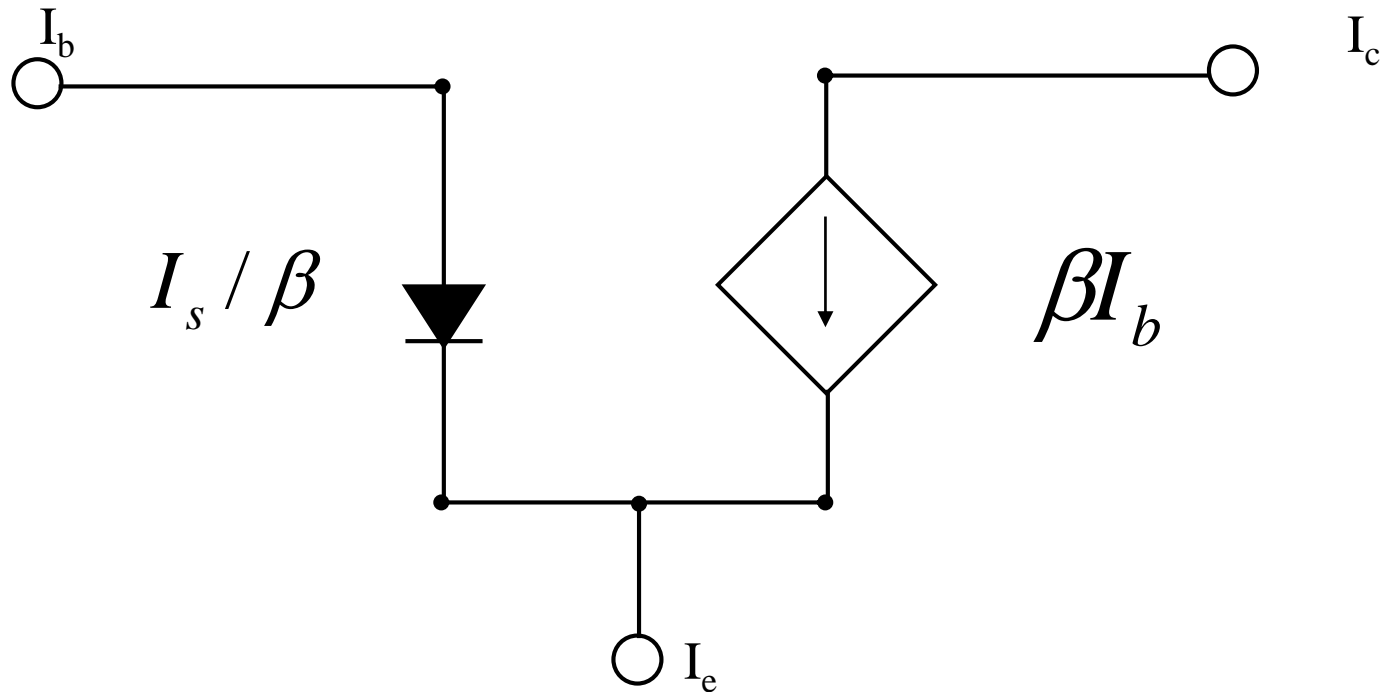

Early effect

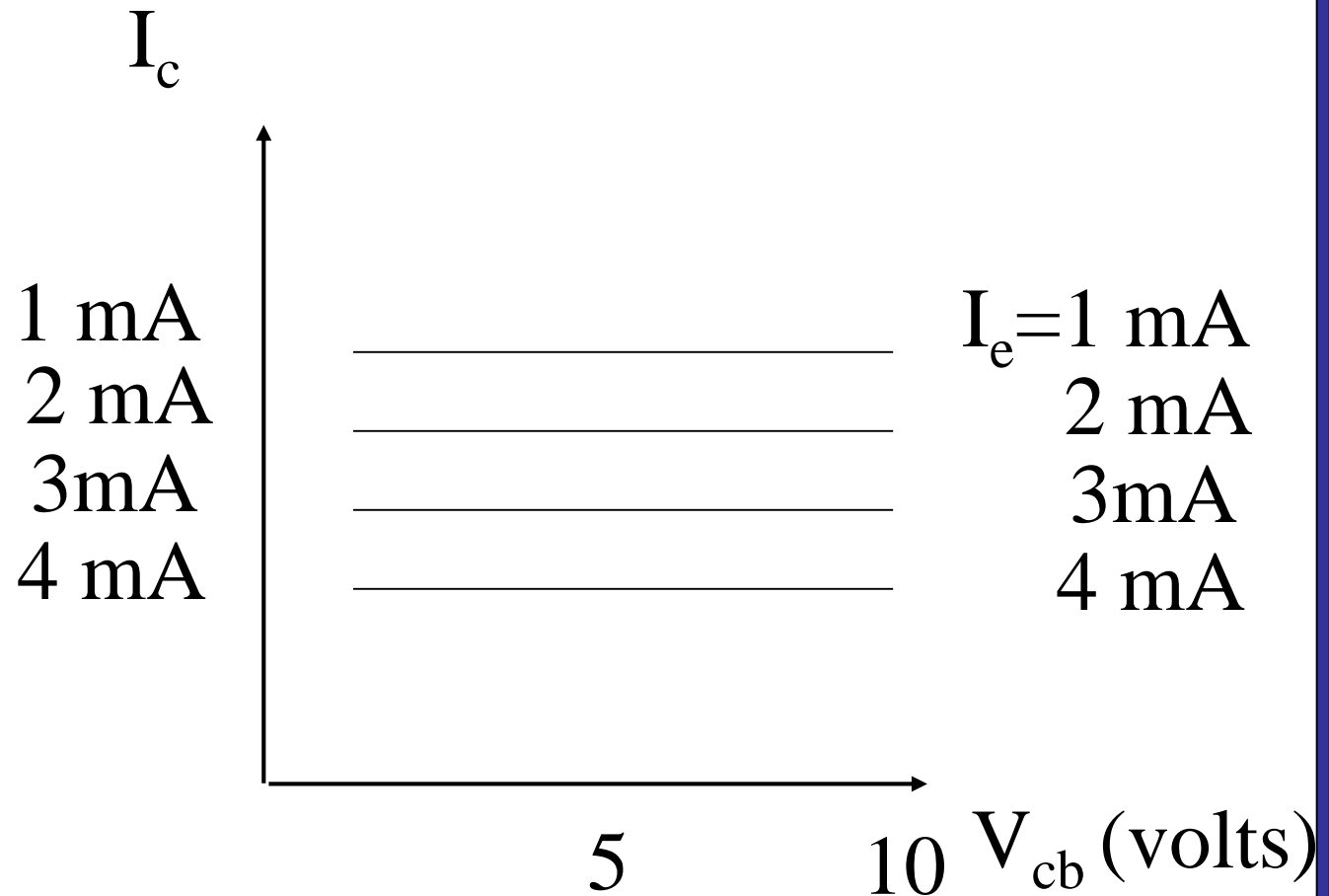

Early effect

$$\frac{I_c}{I_b} \equiv \beta \gg 1$$

$$\frac{I_c}{I_b} \approx \frac{\tau_n}{\tau_t}$$

1 mA
2 mA
3 mA
4 mA

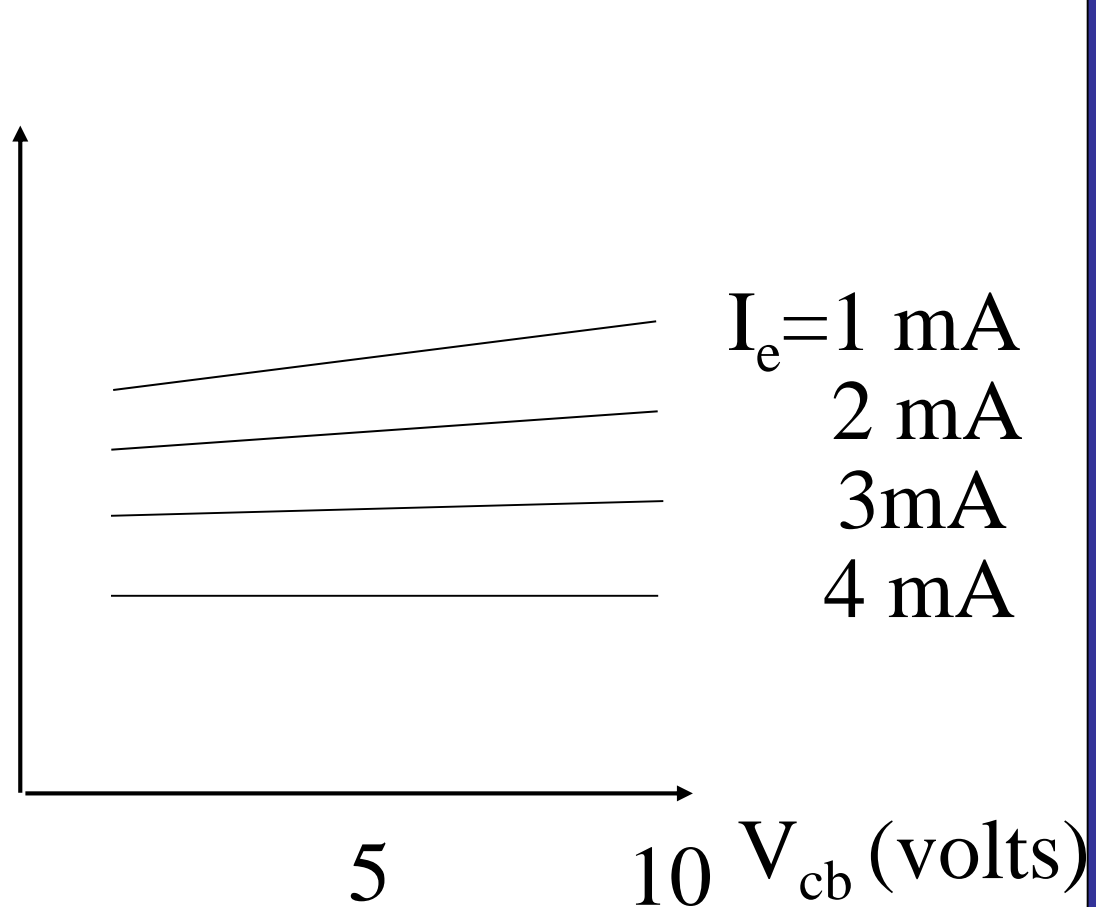

W changes with V_{cb} .

Bipolar advantages

- Speed set by base width, which is easy to control
- Large area contributes to current, good for power

Bipolar dis-advantages

- Need base current at dc
- No easy complementary digital logic